

## **IMRO**

### **Application for Registration Under Section 175 of Copyright and Related Rights Act 2000**

#### **S175(7)(e) & (f) Licensing Schemes Managed by Irish Music Rights Organisation:**

##### **5. Making Available Schemes (Internet)**

- (i)** Joint MCPSI and IMRO Licensing Scheme for the Provision of Online and Mobile Music Services to the Public for Private Use
- (ii)** MCPSI and IMRO Joint Limited Online Exploitation Licence 2022
- (iii)** Joint MCPSI and IMRO Ringtones Licensing Scheme
- (iv)** Joint MCPSI and IMRO Podcasting Licence
- (v)** IMRO Copyright Licence for Ringbacks
- (vi)** IMRO Online Licence excluding JOL Music Services and Ringtones/Ringback
- (vii)** IMRO Licensing Scheme for the Provision of Online and Mobile Download Music Services to the Public for Private Use
- (viii)** IMRO/MCPSI General Entertainment On-Demand Licence for Cable Operators
- (ix)** Joint IMRO-MCPSI Vinyl Copy Code
- (x)** IMRO MCPSI Joint General Entertainment Licence SVOD
- (xi)** IMRO/MCPSI Joint General Entertainment Online Licence (Download-to-Own and On Demand Rental Version)
- (xii)** IMRO Music Download Licensing Scheme
- (xiii)** IMRO MCPS Limited Online Exploitation plus Licence
- (xiv)** IMRO Performing Right Online Licence

# **JOINT MCPSI AND IMRO LICENSING SCHEME FOR THE PROVISION OF ONLINE AND MOBILE MUSIC SERVICES TO THE PUBLIC FOR PRIVATE USE**

## **1. ONLINE AGREEMENT**

- 1.1 The terms and conditions contained in the standard form Online Agreement (“the Online Agreement”) which is set out in Appendix 1 will apply to an online and/or mobile Music Service where:-
- (a) the service provider has applied to MCPSI and IMRO for that Agreement; and
  - (b) MCPSI and IMRO have granted that application in writing;
- 1.2 Application for an Online Agreement shall initially be in the form set out in Appendix 2, but MCPSI and IMRO shall be entitled to ask reasonable further questions to satisfy themselves of the eligibility of the applicant.

## **2. AVAILABILITY OF ONLINE AGREEMENT**

- 2.1 The Online Agreement is available to providers of online and mobile music services:
- (a) who, in relation to such services, are the Music Service Provider (as that term is defined within the Online Agreement); and
  - (b) where the royalties payable (as defined in the Online Agreement) in relation to such music service(s) would be likely to be more than three hundred euro (€300) per year.
- 2.2 Where a Quarterly Advance is payable under the Online Agreement, it shall be a minimum of one hundred euro (€100) per Quarter.
- 2.3 Where 2.1(b) above does not apply, alternative licensing arrangements may be offered to the provider.

## **3. TERRITORY**

The territory covered by the Online Agreement is Ireland. The position as to which additional countries (and in respect of which repertoire) can be included within the definition of ‘Territory’ may change throughout the Term. MCPSI and IMRO will inform the applicant for an Online Agreement as to which additional countries may be covered at the time of application.

4. LINKS TO UNLICENSED MUSIC

MCPSI and IMRO shall have the right to refuse to license any service which provides internet or mobile "links" to unlicensed music (whether in the form of recordings or notation, scores, lyrics, etc).

5. DEPOSITS AND FINANCIAL GUARANTEES

MCPSI and IMRO may make the grant of an Online Agreement conditional upon the provision of such financial guarantees (by way of example only, deposits or advances) as are reasonably necessary to provide security against the risk that the members of MCPSI and IMRO may not receive such royalties as may be payable under the Online Agreement. Upon termination of an Online Agreement, MCPSI and IMRO shall release or repay any guarantee or similar security and shall repay any deposit or similar payment with accrued interest within 14 days of the latest of (a) termination, or (b) the Licensee having materially complied with all of its obligations under the Online Agreement for a period of not less than one year or (c) resolution of any claim under any audit or other claim in relation to which notice was given to the Licensee prior to such termination.

For the avoidance of doubt, any guarantees under this provision are separate from the Quarterly Advance referred to in clause 7 of the Online Agreement and no interest shall be payable on any Quarterly Advance.

6. COMMENCEMENT AND TERM OF SCHEME

This scheme shall take effect on 1<sup>st</sup> January 2024 and shall continue to apply from year to year thereafter unless replaced by an updated licensed scheme and / or tariff.

# APPENDIX 1

## THIS AGREEMENT IS MADE BETWEEN

**IRISH MUSIC RIGHTS ORGANISATION CLG** whose registered office is at Copyright House, Pembroke Row, Lower Baggot Street, Dublin 2, Ireland (“IMRO”) contracting for and on behalf of itself and for and on behalf of and as agent of the Associated Societies (as defined below); and

**MECHANICAL-COPYRIGHT PROTECTION SOCIETY IRELAND LIMITED** whose registered office is at Copyright House, Pembroke Row, Lower Baggot Street, Dublin 2, Ireland (“MCPSI”) contracting for and on behalf of and as agent of **MECHANICAL-COPYRIGHT PROTECTION SOCIETY LIMITED** having its registered office at 2<sup>nd</sup> Floor, Synergy House, 114-118 Southampton Row, London, WC1B 5AA, England (“MCPS”) and its various Members and the Associated Societies (as defined below); and

**THE LICENSEE** (as set out in schedule 6)

## WHEREAS

- (A) The Licensee wishes to offer an online and/or mobile music service within the meaning set out in this Agreement;
- (B) IMRO and MCPSI have developed a joint licensing scheme for licensing musical works for use in such online and mobile music services;
- (C) IMRO and MCPSI have agreed to license musical works to the Licensee on the above basis and upon the terms and conditions contained in this Agreement.

## NOW IT IS HEREBY AGREED AS FOLLOWS

### 1. Definitions

- “the Act”** means the Copyright, and Related Rights Act 2000, as amended from time to time.
- “Agreement”** means these terms and conditions, the schedules to the terms and conditions and part A of the application form completed by the Licensee.
- “Associated Society”** means each collecting society (or other body representing rights in Musical Works) with which MCPS and/or IMRO has, from time to time, an agreement under which MCPS and/or IMRO is authorised to grant licences in relation to the other society's (or body's) repertoire for the purpose of this Agreement PROVIDED THAT where such an

agreement is only entered into after the commencement of the Term, a collecting society (or other body) shall only be regarded as an “Associated Society” for the purposes of this Agreement with effect from the date of signature of such agreement with MCPS and/or IMRO (as applicable).

**“Associated Society Member”**

means any person, firm or company who or which has been notified, from time to time, as being a member of an Associated Society by the relevant Associated Society to MCPS and/or IMRO.

**“Audio-Visual Material”**

means any specific presentation of Musical Works in conjunction with images, whether moving or still. For the avoidance of doubt (but without prejudice to the express restrictions contained in this Agreement), the following shall not be treated as Audio-Visual Material for the purpose of this Agreement:

- (a) the fact that ordinary web pages (or equivalent) are visible to the User while the User is listening to music; or
- (b) the fact that the media player used to play the music generates random visual images while the music is playing;

provided, in both cases, that the User would not reasonably be expected to associate the Repertoire Works being played with the images presented or think that there is any deliberate association by the Licensee of the Repertoire Works with such images.

**“Commencement Date”**

means the date specified in schedule 6.

**“Commercial Work”**

means any Repertoire Work other than:

- (a) one where the Member owning or controlling the copyright in such Repertoire Work has authorised MCPS to license it as so-called production or library music; or
- (b) a Commissioned Work, PROVIDED THAT for the purposes of clauses 3.2 and 4.5, a Commissioned Work shall not be excluded

from such definition where the commissioning agreement does not authorise the Licensee to use the Commissioned Work in the context set out in those clauses.

<b>“Commissioned Work”</b>	means a Musical Work specially and expressly commissioned by the Licensee from composer/writer members of IMRO and/or MCPS.
<b>“Data Storage Device”</b>	means any medium on which data can be stored (whether temporarily or permanently) whether existing now or invented in the future.
<b>“Dramatico–Musical Work”</b>	means any ballet, opera, operetta, musical, musical play or work of a similar nature.
<b>“Electronic Reporting Format”</b>	means the format set out in schedule 4. If and when the DDEX format is agreed within the industry, the DDEX format shall replace the format set out in schedule 4 within 6 months of such agreement unless otherwise agreed between the parties, acting reasonably.
<b>“Gross Revenue”</b>	shall have the meaning set out in schedule 3.
<b>“Licensed Services”</b>	means the Music Services listed in schedule 6.
<b>“Licensee”</b>	means the party set out as such in schedule 6.
<b>“Licensors”</b>	means IMRO and MCPSI.
<b>“Member”</b>	means:  (a) in the case of MCPSI, each person, firm or company who or which, from time to time, has appointed MCPS as agent in relation to online exploitation either before or during the Term other than where such person, firm or company has opted not to participate in the licensing scheme pursuant to which this Agreement has been entered into, PROVIDED THAT a member who has so appointed MCPS after the commencement of the Term shall only be regarded as a member for the purposes of this Agreement with effect from the date on which the Member so appointed MCPS; and  (b) in the case of IMRO, any person, firm or

company who or which, from time to time, pursuant to the Articles of Association of IMRO has been admitted either before or during the Term as a member of IMRO other than where such person, firm or company has reserved to himself or itself the relevant rights pursuant to the Articles of Association and Rules and Regulations of IMRO, PROVIDED THAT a member who has been so admitted after the commencement of the Term shall only be regarded as a member for the purposes of this Agreement with effect from the date of admission into IMRO.

- “Month”** means a calendar month.
- “Musical Work”** means any musical work (as defined in the Act) and any lyrics or words written to be used with such musical work (if applicable). It includes any part of such a work.
- “Music Service Provider”** means, the party which, in relation to a Music Service, most closely meets the following criteria:
- (a) contracts with the User in relation to the provision of the Licensed Service;
  - (b) sets and controls the price the User pays;
  - (c) can fully report on all elements of Gross Revenue (including relevant advertising revenues);
  - (d) can fully report on all elements of music usage (or can procure such reporting);
  - (e) controls how content is offered and bundled within the Licensed Service;
  - (f) carries out or authorises, on their instruction, the carrying out of the copyright restricted acts licensed under this Agreement.
- “Music Usage Information”** means the information referred to in the Electronic Reporting Format.
- “Music Videogram”** means any audio-visual production:
- (a) which has as the main feature of the soundtrack thereof a recording of a single

Repertoire Work copies of which recording have been or are intended to be released as audio records for sale to the general public; and

- (b) the making of which was carried out by or on behalf of the record company releasing that recording or by or on behalf of the main artist(s) featured in that recording.

**“Music Service”**

means a music service falling within the definition set out in schedule 1.

**“Permitted Excerpts”**

refers only to Dramatico-Musical Works and means excerpts where the use of all such excerpts in any Audio-Visual Material complies with all the following limitations:

- (a) the total duration of the excerpts does not exceed 20 minutes;
- (b) the use is not a "potted version" of the Dramatico-Musical Work;
- (c) the use is not or does not cover a complete act of the Dramatico-Musical Work;
- (d) each excerpt is not presented in a "dramatic form" as defined below; and
- (e) as regards ballets specifically devised for television or excerpts from existing ballets, the total duration does not exceed five minutes.

A dramatic form shall be deemed to be created only by a performance in which there is a distinct plot depicted by actors and where the story of the Dramatico-Musical Work and/or its associated words is woven into and carries forward the plot and its accompanying action (a dramatic form shall not, for example, be deemed to be created by the use of costume, scenery, and/or any dance routine merely to provide an acceptable presentation of the work). For the purposes of this paragraph the word "actors" shall include actors, singers, mimics and/or puppets.

**“Quarter”**

means each of the periods from 1<sup>st</sup> January to 31<sup>st</sup> March, 1<sup>st</sup> April to 30<sup>th</sup> June, 1<sup>st</sup> July to 30<sup>th</sup> September, and 1<sup>st</sup> October to 31<sup>st</sup> December,



throughout the Term.

- “Quarterly Advance”** means the sum set out in schedule 6, excluding VAT (or other equivalent sales tax, as applicable).
- “Relevant Party”** means a party which is involved in the provision of the Licensed Services, as set out in clause 15.2.
- “Repertoire Work”** means each Musical Work the relevant copyright in which is owned or controlled, from time to time, in Ireland by:
- (a) MCPSI on behalf of MCPS or a Member or an Associated Society or an Associated Society Member PROVIDED THAT (i) if one or more of those who own or control the copyright in a relevant Repertoire Work is not MCPSI on behalf of MCPS or a Member or an Associated Society or Associated Society Member, the expression "Repertoire Work" shall only apply to such interest in the Repertoire Work as is owned or controlled by MCPSI on behalf of MCPS or the Associated Society or the relevant Member or Associated Society Member, and (ii) it shall exclude any Musical Works that a Member of MCPS or an Associated Society has withdrawn or withheld from this Agreement; and
  - (b) IMRO or a Member or an Associated Society or an Associated Society Member PROVIDED THAT if one or more of those who own or control the copyright in a relevant Repertoire Work is not IMRO or a Member or an Associated Society or Associated Society Member, the expression "Repertoire Work" shall only apply to such interest in the Repertoire Work as is owned or controlled by IMRO or the Associated Society or the relevant member or Associated Society Member.

For the avoidance of doubt, if a Musical Work is a Repertoire Work in relation to one Licensor and not the other then it remains a Repertoire Work under this Agreement in relation only to the licence granted by that Licensor.

- “Reporting Date”** means:
- (a) where the Licensee is undertaking monthly

accounting in accordance with clause 6, 5.00pm on the Friday following the Month to which the reporting relates; or

- (b) where the Licensee is undertaking quarterly accounting in accordance with clause 7, one month following the Quarter to which the Music Usage Information relates.

**“Royalty Fee”** means the royalties payable as set out in schedule 2.

**“Server Territory”** means the European Economic Area, Switzerland, the United States of America, Canada and such other territories as may be agreed in writing by the parties.

**“Term”** means the period starting on the Commencement Date and ending upon the date set out in clause 13.1 (unless terminated earlier under clauses 4.6, 13.2, 13.3, 13.4 or 13.5).

**“Territory”** means Ireland, and those territories (if any) listed in schedule 6 (subject always to clause 4.6 and schedule 2, paragraph 5) and such other countries as the Licensors and the Licensee may agree in writing.

**“Ireland”** means the territory under the government of Ireland and known as the Republic of Ireland.

**“User”** means a natural person in the Territory who receives the Licensed Services for their own private and non-commercial use.

**“VAT”** means value added tax pursuant to the Value Added Tax Act 1972-2004 and each like tax imposed in addition to or in substitution therefor.

**“Week”** means a week starting on Monday and ending on Sunday.

## **2. Grant of Licence**

2.1 Subject to and conditional upon compliance with the terms and conditions contained herein and in particular subject to the exclusions and restrictions set out in clauses 3 and 4, MCPSI grants the Licensee a non-exclusive licence to do the following during the Term:

- (a) to reproduce Repertoire Works on servers within the Server Territory for the purpose of transmitting the same to Users (for the User's own private and non-commercial use) by means of the Licensed Services; and
- (b) where the Licensed Services expressly authorise the temporary or permanent reproduction of Repertoire Works on Users' Data Storage Devices, to cause such copies to be made in the Territory for the User's own private and non-commercial use; and
- (c) to authorise the reproduction of "pre-loaded" copies of Musical Works on Data Storage Devices and distribute such Data Storage Devices to the public within the Territory in an encrypted or other protected form within consumer electronic equipment where the Repertoire Works are solely intended to be accessible at a later date only to Users (for their own private and non-commercial use) through the Licensed Services. For the avoidance of doubt, the royalties set out in schedule 2 (including the Minimum Royalties) shall be payable in respect of Musical Works "pre-loaded" in accordance with this sub-clause 2.1(c). However, the royalties in respect of such "pre-loaded" Musical Works shall not accrue until the User has become able to access and play such Musical Works. This is without prejudice to the obligation of the Licensee to pay the Quarterly Advance.

For the avoidance of doubt (but subject to all terms of this Agreement, in particular clause 3.3), it is intended that this Agreement licenses all reproductions of Repertoire Works necessary in the ordinary operation of the Licensed Services.

- 2.2 Subject to and conditional upon compliance with the terms and conditions contained herein and in particular subject to the exclusions and restrictions set out in clauses 3 and 4, IMRO grants the Licensee a non-exclusive licence, during the Term, to make available (as that term is defined in section 40 (1) (a) of the Act (but not for the avoidance of doubt section 40 (1) (b) to (g) inclusive of the Act) and to authorise the making available to the public of Repertoire Works within the Territory solely as part of and for the purposes of the provision of the Licensed Services.
- 2.3 The above licences shall apply where Repertoire Works are used in audio-only material and, subject to clause 3.2, Audio Visual Material.
- 2.4 The Licensors will not unreasonably refuse or delay any request by the Licensee to include further services of the Licensee within the scope of this Agreement provided that:
  - (a) they are a Music Service; and

- (b) the Licensee is, in relation to that service, the Music Service Provider; and
  - (c) they are otherwise within the scope and limitations set out in this Agreement.
- 2.5 The provisions of clauses 3.2, 3.6, 4.1, 4.2, 4.4 and 4.5 shall not apply to a particular Repertoire Work where the owner of the relevant rights in such Repertoire Work has granted permission to the Licensee for the use of that Repertoire Work on the Licensed Services in the manner described under the relevant clause on such terms and conditions (including, if required, the payment of royalties or fees in addition to those specified under this Agreement) as the owner thinks fit.
- 2.6 The licences granted in clauses 2.1 and 2.2 above shall not apply to any Licensed Service which knowingly or recklessly provides internet or mobile “links” to music which requires a licence, but is unlicensed (whether in the form of recordings or notation, scores, lyrics, etc). The inclusion of such links on a Licensed Service shall constitute a material breach of this Agreement (which is capable of remedy).
- 2.7 Where the Licensee wishes to launch a service where music is the primary theme of such service, but such service does not fall within the definition of Music Service as set out schedule 1 to this Agreement, then the Licensors agree to enter into good faith discussions with the Licensee concerning the inclusion of such new service within the scope of this Agreement and the appropriate royalty rate and minima which shall be applicable.

### **3. Exceptions and Limitations**

- 3.1 The licences granted under clause 2 of this Agreement are valid only insofar as:
  - (a) the Licensed Services are Music Services; and
  - (b) the Licensee is the Music Service Provider in relation to the Licensed Services.
- 3.2 Subject to clause 2.5, the incorporation of Commercial Works into Audio-Visual Material is only licensed under this Agreement where the Audio-Visual Material consists of:
  - (a) a Music Videogram; or
  - (b) a live concert performance or a film of a live concert performance by the artist performing that particular Commercial Work; or

- (c) subject to clause 4.5, such Commercial Works being combined with photographs or other images relating to the artist performing the Commercial Work or the composer of the Commercial Work; or
- (d) subject to clause 4.5, an interview with an artist, composer, producer or other person involved in the creation, performance or production of music where the Commercial Work(s) used are associated with the interviewee(s); or
- (e) where permitted under clause 4.1, a performance of Permitted Excerpts of the Dramatico-Musical Work of which the Commercial Work forms part.

For the avoidance of doubt, such Audio-Visual Material as is licensed under 3.2(a) to (e) above is only licensed insofar as it is reproduced or made available to the public via the Licensed Services.

- 3.3 For the avoidance of doubt, this Agreement does not grant any “synchronisation licence” (to the extent that such a licence may be required by the Licensee) covering the initial fixation of Repertoire Works in combination with visual images to create and produce Audio-Visual Material.
- 3.4 For the avoidance of doubt and except as specifically provided for in clause 2.1(c), the licences granted under clause 2 of this Agreement shall not authorise the manufacture or distribution of physical products containing Repertoire Works, such as (without limitation) the ordering of compact discs (or any other type of physical media) via a Music Service, but which are distributed by mail.
- 3.5 For the avoidance of doubt, the licences granted under clause 2 of this Agreement shall not extend to the performing, showing or playing a copy in public, broadcasting a copy, including a copy in a cable programme service, issuing copies of, or renting or lending (as those terms are used in the Act) of Repertoire Works, whether as part of the Licensed Services or otherwise.
- 3.6 Subject to clause 2.5 and paragraph 5 of schedule 3, the licence granted under clause 2.1 of this Agreement shall not permit the use of Repertoire Work(s) with any advertising or sponsorship of whatsoever nature where:
  - (a) such Repertoire Work(s) are incorporated into such advertising or sponsorship; or
  - (b) such Repertoire Work(s) are otherwise presented in such a way that a reasonable person might associate the Repertoire Work(s) with the advertising or sponsorship.

3.7 Subject to paragraph 5 of schedule 3, for the avoidance of doubt (but without prejudice to the generality of clause 3.6), the licences granted under this Agreement shall not apply to any Repertoire Work(s) made available for the purpose of (whether in whole or in part):

- (a) directly or indirectly encouraging the User to purchase or obtain goods or services of whatsoever nature (other than music via the Licensed Service); or
- (b) promoting the branding of the Licensee, any affiliate of the Licensee or any third party;

in such a manner that:

- (i) one or more particular Repertoire Works, composers or writers are associated with such promotion; or
- (ii) a reasonable person might assume that there was an association between particular Repertoire Works, composers or writers and such promotion.

3.8 The licence granted under clause 2.1 shall not apply to graphic copies (meaning, without limitation, copies of lyrics, notation or scores) of Repertoire Works. For the avoidance of doubt, the licences granted under this Agreement shall not apply to any “karaoke” service within a Music Service.

3.9 The licence granted under clause 2.2 shall only apply to a Repertoire Work made available to the public as part of a Licensed Service where the Licensee has the benefit of a valid licence for or a right to make a reproduction of that particular Repertoire Work and for that particular form of exploitation via the Licensed Service either pursuant to this Agreement or otherwise. By way of example only, the licence granted by MCPSI under clause 2.1 does not cover the copying of Repertoire Works in an advertisement (see clause 3.6 above). However, clause 3.6 does not apply to the licence granted by IMRO under clause 2.2. Therefore, pursuant to this clause 3.9, the licence granted by IMRO under clause 2.2 would not apply (in the context of this example) unless the Licensee has the benefit of a right to copy the Repertoire Work for use in that advertisement (and on the Licensed Services).

3.10 For the avoidance of doubt, this Agreement grants no licence whatsoever in relation to Repertoire Works which are made available by the Licensee outside of the Licensed Services. However, such other exploitation of Repertoire Works may fall within the scope of other licensing schemes operated by the Licensors, details of which shall be made available to the Licensee on request.

3.11 For the avoidance of doubt, this Agreement grants no licence whatsoever in relation to Repertoire Works which are made available by

the Licensee to Users outside the Territory. However it is acknowledged that Users in the Territory may receive the Licensed Services for their own private and non commercial use while outside the Territory and to the extent that this occurs the Licensee agrees to abide by the terms of this Agreement in respect of the Licensed Services as so received unless the Licensee establishes to the reasonable satisfaction of the Licensors that the Licensee is otherwise licensed by the copyright owners in respect of the use of the Repertoire Works as aforesaid.

#### **4. Further Restrictions**

4.1 Subject to clause 2.5, where any Repertoire Work forms part of any Dramatico-Musical Work, the licence granted under clause 2.1 shall not apply, in relation to Audio-Visual Material, to the reproduction of:

- (a) the whole Dramatico-Musical Work; or
- (b) any excerpt(s) from such Dramatico-Musical Work unless all of the following circumstances apply:
  - (i) that which is copied or made available to the public via the Licensed Services under this Agreement contains only excerpt(s) within the definition of Permitted Excerpts; and
  - (ii) neither of the Licensors has notified the Licensee in writing that their Member or the Associated Society Member objects to the reproduction of any such Repertoire Work.

4.2 Subject to clause 2.5, where any Repertoire Work forms part of any Dramatico-Musical Work, the licence granted under clause 2.1 shall not apply, in relation to material other than Audio-Visual Material, to the reproduction of the whole or substantially the whole Dramatico-Musical Work unless:

- (a) the Licensee has specifically notified the Licensors that it wishes to reproduce the whole or substantially the whole work; and
- (b) the Licensors have notified the Licensee that all relevant Members consent to such reproduction.

For the purposes of this clause 4.2, the expression “Dramatico-Musical Work” shall include any version of such work (with or without cuts, additions, interpolations or the like) which has been publicly performed. Furthermore, for the avoidance of doubt, substantially the whole work shall be deemed to be reproduced where all or nearly all the individual songs or other music included in the work are reproduced.

4.3 In any event, any licence hereunder only applies to the relevant Repertoire Works and not (by way of example only) to any underlying dramatic or literary work which forms part of the Dramatico-Musical Work or which such Dramatico-Musical Work is based on or uses.

4.4 Subject to clause 2.5, the licences granted under this Agreement shall not extend to or permit any adaptation of any Repertoire Work to be copied or made available to the public as part of a Licensed Service unless the relevant Member has consented to such adaptation. By way of example only, this applies to:

- (a) any sampling (meaning the taking of part of the music and/or lyrics of a Repertoire Work and incorporating such part into another Musical Work) or the making available of or reproduction in the form of a sample of such part of a Repertoire Work; or
- (b) using with music lyrics other than those written to be used with the music or authorised for use with the music; or
- (c) using with lyrics music other than that written to be used with the lyrics or authorised for use with the lyrics.

However, subject always to clause 4.10 and provided that such alterations do not amount to an adaptation of a Repertoire Work and do not contravene clause 4.5, then this Agreement shall apply in relation to Repertoire Works that have been modified (including music and/or lyrics) for the purpose of satisfying the requirements of the relevant recording.

For the avoidance of doubt, the Licensors acknowledge, for the purposes of the restriction set out in this clause 4.4, that the production and inclusion as part of the Licensed Services of audio clips of Repertoire Works of up to 30 seconds (or, for "classical" genre Repertoire Works, up to 1 minute) duration to promote the supply of music via the Licensed Services does not of itself constitute an adaptation or sample.

4.5 Subject to clause 2.5, the licences granted under this Agreement shall not extend to:

- (a) the reproduction or making available to the public of any Commercial Work or part thereof in the form of a parody or burlesque of any Commercial Work or of any composer or writer of any Commercial Work or any band or other group of artists which includes any composer or writer of any Commercial Work; or
- (b) the use of any Commercial Work in any context which the Licensee ought reasonably to consider as being likely to be insulting or detrimental to the composer featured on the



commercially released sound recording of the music or the relevant Member or Associated Society Member.

- 4.6 Any additional limitations in relation to the Licensors or the Associated Societies' rights to grant the licences set out in clause 2 of this Agreement which have been notified to the Licensors shall be notified to the Licensee in writing (which may include by email) and shall be binding no less than 10 days following such notice. Where any restriction of a material nature is added, the Licensee shall have the right to terminate this Agreement by giving written notice to the Licensors.
- 4.7 All rights not specifically granted under this Agreement are hereby reserved.
- 4.8 This Agreement only covers Repertoire Works. It does not extend to other rights or interests, including (by way of example only), rights in sound recordings, films, dramatic works, performers' rights or rights in performances. The Licensee is required to obtain the appropriate waivers, consents and/or licences from the person(s) owning or controlling rights in relation to sound recordings containing Repertoire Works or performers of that Repertoire Work.
- 4.9 It is the responsibility of the Licensee to obtain all necessary licences in relation to any Musical Work which is not, or to the extent that it is not, a Repertoire Work, and no licence is granted under this Agreement in relation thereto.
- 4.10 Nothing in this Agreement affects the moral rights of authors of Repertoire Works whether subsisting in Ireland or any other territory.

## **5. Payment and Accounting**

- 5.1 Where the Licensors are satisfied that:
- (a) the projected Gross Revenue of the Licensee during the first year of the Agreement is over seven hundred thousand euro (€700,000) (excluding VAT or other equivalent sales tax), such figure to be increased each calendar year in accordance with the Consumer Price Index change over the previous calendar year; and
  - (b) there is no adverse credit risk causing the Licensors to have reasonable concerns over the Licensee's ability to pay royalties due under this Agreement; and
  - (c) the Licensee is capable of accurately reporting and paying royalties on a monthly basis in accordance with the provisions of this Agreement;

then the Licensee shall pay royalties in accordance with clause 6 below.

- 5.2 Otherwise, the Licensee shall pay royalties in accordance with clause 7 below.
- 5.3 All licence fees and payments referred to in this Agreement are subject to VAT or other equivalent sales tax. The Licensee shall pay to the Licensors VAT or other equivalent sales tax (if applicable) at the rate or rates from time to time in force on any sums payable under this Agreement.
- 5.4 Except as expressly set out in this Agreement, no deduction in respect of any tax, or any other deduction or set-off of whatsoever nature, shall be made in calculating or paying any sum due under this Agreement.
- 5.5 Notwithstanding the provisions of clauses 6 and 7 below, the Licensors confirm and warrant that the MCPSI and IMRO are authorised to receive all payments under this Agreement as agent on behalf of in the case of MCPSI, MCPS and in both cases on behalf of each of the Members and, subject to clause 4.6, the Associated Societies.
- 5.6 Without prejudice to any other right or remedy of the Licensors, and without imposing an obligation to accept late payment, where any fees payable under this Agreement are not paid by the due date (or the date on which such fees should ordinarily have been paid in circumstances where the Licensors have been unable to submit an invoice) due to default of the Licensee, the Licensee shall (if required by the Licensors) pay interest on such late payment calculated on a daily basis at an annual rate of 3% over the prime overdraft rate, current from time to time, of Bank of Ireland payable from the date on which the payment should have been made to the date on which the payment was made.
- 5.7 All payments made under this Agreement shall be in euro unless otherwise agreed by the parties in writing. Where it is necessary to convert an amount payable to euro from another currency, the exchange rate used shall be the Irish Times closing mid market rate on the last working day of the Month or Quarter as applicable to which the payment relates. The Licensee shall pay all bank charges on transfers of sums payable by the Licensee to the Licensors.
- 5.8 The address for delivery of the royalty statement referred to in clauses 6.2 and 7.5 is MCPSI/IMRO Copyright House, Pembroke Row, Lower Baggot Street, Dublin 2.
- 5.9 In relation to Permanent Download Services and LD/ODS Services only, if and insofar as, (i) a Musical Work is not in copyright in the relevant part of the Territory, or (ii) it is not a Repertoire Work, credit shall be given by either or both of the Licensors (as the case may be) for any overpayment of royalties. The parties shall discuss in good faith the mechanism for calculating and granting any rebate for Musical Works which are not Repertoire Works. Unless and until agreed otherwise, the

terms set out in this Agreement shall apply, it being acknowledged by the Licensors that it may then be necessary to make adjustments to payments that have already been made by the Licensee to the Licensors as from the Commencement Date so as to allow for royalties paid on Musical Works that are not Repertoire Works.

- 5.10 Notwithstanding the above, for Music Services where a significant proportion of Musical Works accessed by Users are either no longer in copyright in the relevant part of the Territory or are otherwise not Repertoire Works (by way of example, services specialising in classical music), the Licensors shall agree an appropriate deduction to the Gross Revenue and Minimum Royalties to apply as from the Commencement Date. This deduction shall be reviewed every six months.

## **6. Fees and Payment – Monthly Accounting**

- 6.1 In consideration of the licences and authorisations granted under this Agreement, the Licensee shall pay to the Licensors the Royalty Fee.
- 6.2 Within 8 working days of the end of each Month, the Licensee shall send to the Licensors a fully and accurately completed royalty statement (in the form attached in schedule 5).
- 6.3 The Licensors shall on behalf of each of the Members and, subject to clause 4.6, the Associated Societies, raise an invoice for the due amount, and the Licensee shall pay such invoice by electronic bank transfer (or, if agreed by the Licensee, direct debit) within 10 days of the invoice date.
- 6.4 Where, in relation to any particular Month, the Licensee fails to provide by the required date the information required under the Agreement to calculate the Royalty Fee, then the Licensors shall be entitled to fix the Royalty Fee based on (a) the Royalty Fees payable in previous Months and (b) any other relevant factors which could reasonably lead the Licensors to believe that the Royalty Fees payable would be materially different from those paid or payable in previous Months.

## **7. Fees and Payment – Quarterly Accounting**

- 7.1 In consideration of the licences and authorisations granted under this Agreement, the Licensee shall pay to the Licensors:
- (a) the Quarterly Advance; and
  - (b) subject to clause 7.2, the Royalty Fee.
- 7.2 The Quarterly Advance is recoupable against the Royalty Fee. If any part of the Quarterly Advance remains unrecouped at the end of a Quarter, such unrecouped amount may be carried over to subsequent quarters, but for the avoidance of doubt, shall not (except as set out in

clause 7.3 below) have the effect of reducing any subsequent Quarterly Advance. If any part remains unrecouped upon termination or expiry of the Agreement, the Licensors shall return such part to the Licensee.

- 7.3 The Quarterly Advance shall be reviewed at the end of each calendar year. It may also be reviewed during a calendar year if the royalties calculated for any particular Quarter under schedule 2 differ from the Quarterly Advance by 20% or more.
- 7.4 Where, in relation to any particular Quarter, the Licensee fails to provide by the required date the information required under the Agreement to allow the calculation referred to in clause 7.1(b), then the Licensors shall be entitled to fix the Royalty Fee based on (a) the Royalty Fees payable in previous Quarters and (b) any other relevant factors which could reasonably lead the Licensors to believe that the Royalty Fees payable would be materially different to those paid or payable in previous Quarters.
- 7.5 The Quarterly Advance shall be payable by electronic funds transfer (or if agreed by the Licensee, direct debit) on the first day of each Quarter. Where the Agreement begins (and/or a Licensed Service comes into operation) within a Quarter, the first Quarterly Advance payment shall be pro-rated (according to the Commencement Date) and shall be payable upon the later of signature of this Agreement and the date on which the first Licensed Service is made available to Users for the first time.
- 7.6 Within 15 working days of the end of each Quarter the Licensee shall provide to the Licensors a fully and accurately completed royalty statement (in the form attached in schedule 5).
- 7.7 The Licensors shall, on behalf of each of the Members and, subject to clause 4.6, the Associated Societies, raise an invoice for the due amount, and the Licensee shall pay such invoice by electronic bank transfer (or, if agreed by the Licensee, direct debit) within 21 days of the invoice date.

## **8. Supply of Information**

- 8.1 In relation to any and all Repertoire Works reproduced and made available to the public (or otherwise accessed through a Licensed Service if from “pre-loaded” copies pursuant to clause 2.1(c)) under this Agreement via all Licensed Services, the Licensee will deliver the Music Usage Information to the Licensors or to the Licensors’ duly authorised agent (details of which will be provided to the Licensee) in the Electronic Reporting Format monthly (where the Licensee is undertaking monthly accounting) or quarterly (where the Licensee is undertaking quarterly accounting) by the Reporting Date.
- 8.2 The Licensee must also supply the Licensors with any further information or documentation in its possession, power, custody or control (and use

its reasonable endeavours to supply the Licensors with any further information or documentation not in its possession, power, custody or control) reasonably requested by the Licensors at any time, in order to enable the Licensors to verify the Repertoire Work(s) which have been reproduced or distributed via all Licensed Services.

- 8.3 Where any or all of the Licensed Services are accessible by Users only on payment of subscription or other similar payment (or access is otherwise limited or controlled in some way), the Licensee shall, upon request of the Licensors, use reasonable endeavours to ensure that such Licensed Services are at all times accessible by the Licensors free of charge for the purposes of the Licensors verifying that the Licensee is acting in accordance with this Agreement. For the avoidance of doubt, the Licensee shall not be required to provide free access to downloads under a Permanent Download Service or to provide free access to a mobile phone network or internet access.
- 8.4 The Licensee acknowledges that the Licensors have a responsibility to maximise the efficiency of their reporting to the Members and the Associated Societies. Therefore, if the Licensors wish to make any reasonable upgrade or alteration of whatsoever nature to the Music Usage Information or data specification referred to in schedule 4 during the Term, the Licensee agrees to use its reasonable endeavours to implement the changes required as soon as is reasonably practicable, PROVIDED THAT the Licensors shall not request that the Licensee implements the change in less than six months from the making of the request, and in each case of a change the following procedures shall apply:
- (a) the Licensors shall give full details thereof in writing to the Licensee;
  - (b) the Licensee will respond in writing within 4 weeks of receipt of the request, stating the date by which it commits to comply with the change and the Licensors shall provide full assistance to the Licensee in order to assist the Licensee in complying with the change; and

the parties will then finalise the details and undertake tests to ensure that the change operates satisfactorily within the terms of this Agreement, satisfactory operation of which will be deemed acceptance of the change and schedule 4 and/or the definition of Music Usage Information will be amended or replaced accordingly. For the purpose of this clause, in determining what change may be reasonable, regard shall be had to the DDEX project.

- 8.5 Without prejudice to any right in law that the Licensors may have to obtain such information, the Licensee shall not be obliged to provide to the Licensors any information which identifies Users or which otherwise constitutes “personal data” as defined in the Data Protection Acts 1988

and 2003. For the avoidance of doubt, the Licensee must still provide all required Music Usage Information (or other information to be provided under this Agreement), but is entitled to remove any element of it which reveals the identity of Users or otherwise causes it to include or constitute “personal data”.

- 8.6 The Licensee shall notify the Licensors in writing in advance of all arrangements which it enters into for “pre-loading” content on Data Storage Devices pursuant to clause 2.1(c), such notification to include details of the relevant Data Storage Devices.
- 8.7 Subject to the permitted uses and disclosures of its confidential information provided for in this agreement, IMRO and MCPSI shall each keep confidential all confidential information provided to IMRO or MCPSI by Licensee pursuant to this Agreement. Licensee though acknowledges that IMRO and MCPSI may disclose the said confidential information to any of its directors, officers, employees, members or sister organisations to the extent that disclosure is reasonably necessary for the purposes of this Agreement and for the purposes of administering the Repertoire Works and accounting to members and sister organisations for the administration of the Repertoire Works.
- 8.8 IMRO may disclose the confidential information referred to in sub clause 1 if and to the extent that:
- (a) this is required by the law of any relevant jurisdiction or pursuant to a request or order of a regulator or court of a competent jurisdiction;
  - (b) this is required by any securities, exchange or regulatory or governmental body to which IMRO or MCPSI is subject;
  - (c) the information is disclosed on a strictly confidential basis to the professional advisers, auditors and bankers of IMRO or MCPSI;
  - (d) the information has come into the public domain through no fault of IMRO or MCPSI;
  - (e) the information was in the possession of IMRO or MCPSI before disclosure by Licensee;
  - (f) it is required to enable IMRO or MCPSI to enforce its rights under this Agreement.

## **9. Late Reporting**

9.1 The following provision applies where the Licensee has:

- (a) failed to deliver prior to the required date Music Usage Information for the Licensed Service; or

- (b) delivered such Music Usage Information prior to the required date, but it contains any omission or error of whatsoever nature (by way of example only, Repertoire Works having been omitted therefrom or incorrectly or misleadingly named, or the duration of any Repertoire Works having been under-reported) which is material and the Licensee has failed to give notice in writing to the Licensors correcting the omission or error by the date upon which such reporting should have been provided.
- 9.2 In such circumstances (and without prejudice to any other rights which either or both Licensors may have against the Licensee) if one or both of the Licensors has distributed some (or all) royalties received (excluding any commission) to Members and/or Associated Societies based on the usage data supplied, but, as a result of clause 9.1(a) or (b) applying, the royalties distributed do not accurately or fairly represent that which each of the Members and/or Associated Societies should have received (when considering the true usage of Repertoire Works), then the Licensee shall pay the fees set out in clauses 9.3 and 9.4 (in addition to those set out in clauses 6 and 7).
- 9.3 Where clause 9.2 applies, separately in relation to each relevant Repertoire Work either omitted from the relevant Music Usage Information or as regards which there was a material omission or error of whatsoever nature or in relation to which the relevant Music Usage Information was not delivered, the additional fees shall be calculated at the rate equivalent to that which has been or will be paid by MCPSI and/or IMRO (as applicable) to their members (or associated societies) in relation to the Music Usage Information which was submitted prior to the required date.
- 9.4 Where clause 9.2 applies, the Licensee will also pay interest on the additional fees as referred to in clause 9.3 above computed in accordance with clause 5.6 and calculated from the date on which MCPSI and/or IMRO (as applicable) first made a distribution to their members (or associated societies) in relation to the relevant period to the date on which the Music Usage Information was received by the Licensors or the date on which the Licensors received written notice of the relevant error, as the case may be.
- 9.5 The provisions of this clause apply notwithstanding any other provision of this Agreement, but are without prejudice to any other right which MCPSI and IMRO have in relation to any failure to submit Music Usage Information fully or accurately completed within the time stipulated in clause 8.1.

## **10. Credits and Notices**

The Licensee shall include on each of the Licensed Services:

- (a) the logos of IMRO and MCPSI; and
- (b) details of the following websites and, where practical, hypertext links to it: [www.IMRO.ie](http://www.IMRO.ie) and [www.MCPS.ie](http://www.MCPS.ie)
- (c) where reasonably practicable, the name of the composer and publisher of the Repertoire Works provided via the Licensed Services; and
- (d) a notice explaining that use of the musical works is subject to restrictions and that a summary of these restrictions may be obtained by accessing the Licensors' website through the link referred to above.

Approval of the Licensors shall be deemed to be given to the positioning of the above credits and notices within the terms and conditions of the Licensed Services where it is not reasonably practical to position such information elsewhere.

## **11. Auditing**

- 11.1 The Licensee shall keep and make available for inspection upon reasonable notice (and shall procure that each Relevant Party keeps and makes available for inspection upon reasonable notice), both during and for twelve months after termination of this Agreement, proper, detailed books and records relating to (a) the use of all Musical Works and (b) any income or other consideration received by or on behalf of the Licensee in relation to the Licensed Services, together with any supporting documentation relating thereto covering the period up to six years prior to the date of notification of audit.
- 11.2 For the purposes of this clause 11, the Licensee shall allow upon reasonable notice (and shall procure that each Relevant Party shall allow) access to its premises to inspect relevant accounting records, but not more than once per annum. The duly authorised representatives (who shall be external qualified accountants or auditors unless otherwise agreed between the parties) of the Licensors shall have such access to the Licensee's premises and shall be entitled to inspect, make extracts and take copies of any of the information and/or documentation available and to carry out such work as is, in their reasonable opinion, considered necessary to verify compliance with the provisions of this Agreement.
- 11.3 If tests under any audit and verification process indicate under-payment of the correct Royalty Fee during the period under audit, then, without prejudice to the Licensors' other rights under this Agreement, the Licensee shall pay the amount of the underpayment plus interest based on the period from which the correct fee should have been paid to the Licensors to the date when it was actually paid (at the rate set out in clause 5.6).



- 11.4 If any audit and verification process discloses (a) under-payment of more than 7.5% of the correct Royalty Fee during the period under audit and/or (b) failures to report correctly (so as to affect a distribution by the Licensors to their Members) amounting to at least 7.5% of the music usage during the period under audit, then, without prejudice to the Licensors' other rights under this Agreement, the Licensee shall pay, in addition to the payment referred to in clause 11.3, the Licensors' reasonable costs of such audit and verification within 28 days of receipt of the Licensors' VAT invoice therefor.
- 11.5 If tests under any audit and verification process indicate over-payment of the correct Royalty Fee during the period under audit, then the Licensors shall, as soon as is reasonably practical, pay the amount of the overpayment back to the Licensee (but, for the avoidance of doubt, no interest shall be payable unless the overpayment is a result of an act or omission of the Licensors (in which case interest shall be payable at the rate set out in clause 5.6)). However, where the overpayment does not result from an act or omission of the Licensors and the Licensors have already distributed such overpayment to their Members and/or Associated Societies, the Licensors shall be entitled to deduct its reasonable internal and/or external costs in administering the payment back of the overpayment.
- 11.6 The Licensors shall not (and shall procure that their representatives shall not), without the Licensee's written consent, disclose to any third party any confidential information of the Licensee (so long as it remains confidential) received in the course of an audit carried out under this clause 11, save that such confidential information may be disclosed to the Licensors' directors, board sub-committee members, officers, employees and professional advisors (solely where such persons are under a duty of confidentiality in relation to information so received and the Licensors shall be liable to the Licensee in respect of any breach of such confidentiality obligation) solely for purposes connected with this Agreement.
- 11.7 For the avoidance of doubt, books, records and accounting records as referred to in clauses 11.1 and 11.2 above shall include data, information and records held on computers.
- 11.8 The Licensee shall, if requested by the Licensors, provide a statement from its auditors (but not more than once per year) confirming that the financial information submitted by the Licensee for the relevant requested period is in accordance with the actual Gross Revenue (as defined under this agreement) for that period.

## **12. Security and Encryption**

- 12.1 Unless agreed otherwise, the Licensee will utilise or require the utilisation of an industry security standard which is developed and is available for use in the protection of Repertoire Works. Until such time,

the Licensee must use its reasonable endeavours to prevent unauthorised copying and/or the unauthorised issuing of copies of Repertoire Works by whatever technical means are practicable. Upon request, the Licensee will inform the Licensors concerning its activities in relation to fulfilling this obligation.

12.2 Save as may be permitted by law, the Licensee agrees it shall not (and shall procure that any Relevant Party shall not) attempt to:

- (a) remove or alter any rights management or identifier information that may be associated with any Repertoire Works; or
- (b) circumvent any technical measures associated with any Repertoire Work which are designed to prevent or restrict the unauthorised use of any Repertoire Work.

### **13. Termination and Expiry**

13.1 This Agreement shall expire on 31 December 2024 unless terminated earlier by written agreement or in accordance with the terms of this clause 13.

13.2 This Agreement may be terminated by either party by the terminating party giving the other party not less than three months notice in writing.

13.3 Each party shall have the right to terminate this Agreement by notice forthwith where the other party:

- (a) commits a material breach of this Agreement which is capable of remedy and fails to remedy such breach within 14 clear days after receipt of notice of such breach; or
- (b) commits a material breach of this Agreement which is not capable of remedy;

and, for the avoidance of doubt, any breach which consists of a failure by either party to perform an obligation under this Agreement within any period required or by any date specified under this Agreement shall be deemed to be capable of remedy if such obligation is performed by such party within the 14 day cure period specified in clause 13.3(a) above.

13.4 The Licensors shall have the right to terminate this Agreement by notice forthwith if the Licensee:

- (a) is dissolved (other than pursuant to a consolidation, amalgamation or merger);
- (b) becomes insolvent or is unable to pay its debts as they become due (as that term is defined in Companies Acts 1963-2006) or

fails or admits in writing its inability generally to pay its debts as they become due;

- (c) makes a general assignment, arrangement or composition with or for the benefit of its creditors;
- (d) institutes or has instituted against it a proceeding seeking a judgment of insolvency or bankruptcy or any other relief under any bankruptcy or insolvency law or other similar law affecting creditors' rights, or a petition is presented for its winding-up or liquidation, and, in the case of any such proceeding or petition instituted or presented against it, such proceeding or petition:
  - (i) results in a judgment of insolvency or bankruptcy or the entry of an order for relief or the making of an order for its examinership, winding-up or liquidation; or
  - (ii) is not dismissed, discharged, stayed or restrained in the case of a winding-up petition within 14 days or in the case of an examinership petition within 2 days, of the institution or presentation thereof;
- (e) has a resolution passed for its winding-up, examinership, or liquidation (other than pursuant to a consolidation, amalgamation or merger);
- (f) seeks or becomes subject to the appointment of an examiner, provisional liquidator, receiver, trustee, custodian or other similar official for it or for all or substantially all its assets;
- (g) has a secured party take possession of all or substantially all its assets or has a distress, execution, attachment, sequestration or other legal process levied, enforced or sued on or against all or substantially all its assets and such secured party maintains possession, or any such process is not dismissed, discharged, stayed or restrained, in each case within 30 days thereafter; or
- (h) causes or is subject to any event with respect to it which, under the applicable laws of any jurisdiction, has an analogous effect to any of the events specified in clauses (a) to (g) (inclusive).

13.5 The licences granted under clause 2 of this Agreement are so granted on the basis of the representations made by the Licensee in part A of the application form.

13.6 Termination of this Agreement for whatever reason shall be without prejudice to any rights which have already accrued to the parties under this Agreement.

#### **14. Effect of Termination**

14.1 Upon termination of this Agreement all licences granted under this Agreement shall terminate and the Licensee shall immediately cease to be licensed by the Licensors for the reproduction or making available to the public of Repertoire Works via the Licensed Services. Termination shall be without prejudice to the ability of Users to retain a copy of a Repertoire Work supplied to them under a Permanent Download Service.

14.2 Clauses 5, 6, 7, 8, 9, 14, 11, 17 and 18 shall survive the termination of this Agreement, but only in relation to the Licensee's activities during the Term.

## **15.No Assignment**

15.1 Subject to clause 15.2, the licences granted under this Agreement are personal to the Licensee and the Licensee may not assign, sub-license or otherwise transfer any or all of its rights or obligations under this Agreement without the written agreement of both MCPSI and IMRO except where the Licensee wishes to assign or transfer its rights and obligations to a direct or indirect subsidiary or direct or indirect holding company of the Licensee in which case the Licensors may not unreasonably withhold consent.

15.2 Subject always to the other provisions of this Agreement, the Licensee shall be permitted to use the services of a third party in operating the Licensed Services, provided that:

- (a) the Licensee retains complete control and direction over the provision of the Licensed Services to Users; and
- (b) the Licensors are able to audit such third party in accordance with clause 11.

15.3 The Licensee shall include the following provisions in its terms and conditions for the supply of the Licensed Services to Users:

- (a) that any Repertoire Works made available to Users may only be copied as permitted under this Agreement or by applicable law; and
- (b) that, save as may be permitted by law, no attempt shall be made by Users to:
  - (i) remove or alter any rights management or identifier information that may be associated with any Repertoire Works; or
  - (ii) circumvent any technical measures associated with any Repertoire Work which are designed to prevent or restrict the unauthorised use of any Repertoire Work.

15.4 The Licensee shall, upon request by either Licensor, supply such Licensor forthwith with a copy of the Licensee's standard terms and conditions applying to the provision of any or all of the Licensed Services.

## **16. Controlled Composition Agreements**

Where any person, firm or company is or becomes a member of MCPS or IMRO or an Associated Society and that party itself or that party's predecessor in title or grantor has a current contract with the Licensee or the Licensee's predecessor in title or grantor:

- (a) to the extent that such contract would otherwise apply in relation to the grant of any or all of the licences referred to in this Agreement and/or the terms and conditions on which such licences are granted, the terms and conditions of this Agreement shall during the subsistence of this Agreement replace the terms and conditions of that contract; and
- (b) upon the written request of the Licensee the relevant Licensor will in the case of MCPSI procure that MCPS does so and in the case of IMRO will provide the Licensee with evidence that the relevant Member has become a Member and has given the MCPS or IMRO or the relevant Associated Society authority to bind the Member as regards this Agreement.

This clause does not prevent the Licensee from obtaining a licence only in relation to the rights referred to in clause 2.1 from the relevant party owning or controlling such rights where such licence is validly obtained whether before or after the Commencement Date but other than as a result of a contract with an individual composer or recording group.

For the avoidance of doubt, where the Licensee is exploiting the relevant rights outside Ireland, and has in relation to such exploitation a valid licence from the Associated Society entitled to grant that licence in relation to the relevant territory or territories, this clause 16 does not operate so as to override the terms of that licence.

## **17. Notices**

17.1 Except where expressly stated otherwise, any notice or other written communication given under or in connection with this Agreement shall only be effective if it is in writing. Faxes and e-mails are permitted save that notices under clause 13 of this Agreement shall not be served by e-mail. In the absence of any legitimate electronic signature system, either party shall be permitted to require the confirmation in writing (signed by an authorised signatory) of any notice originally sent by email.

17.2 The address for service of any party shall be its registered office marked for the attention of the Chief Executive or Managing Director, or, if any other address or addressee for service has previously been notified to the server, to the address so notified.

17.3 Any such notice or other written communication shall be deemed to have been served:

- (a) if personally delivered, at the time of delivery;
- (b) if posted, at the expiry of two business days or in the case of airmail four business days after it was posted;
- (c) if sent by facsimile message or e-mail, at the time of receipt of transmission (if received during normal business hours that is 9.00 to 17.00 local time) in the place to which it was sent or (if not received during such normal business hours) at the beginning of the next business day at the place to which it was sent.

17.4 In proving service of a notice it shall be sufficient proof that personal delivery was made, or that such notice or other written communication was properly addressed stamped and posted or in the case of a facsimile message or e-mail that an activity or other report from the sender's facsimile machine or computer can be produced in respect of the notice or other written communication, in the case of a fax, showing the recipient's facsimile number and the number of pages transmitted.

## **18. Miscellaneous**

18.1 No delay or omission in exercising any right or remedy hereunder shall operate as a waiver thereof or of any other right or remedy and no single or partial exercise thereof shall preclude any other or further exercise thereof or the exercise of any other rights or remedies. No waiver shall be binding or effectual for any purpose unless expressed in writing and signed by the party giving it and any such waiver shall be effective only in the specific instance and for the purpose given.

18.2 This Agreement sets forth the entire agreement of the parties in relation to the subject matter hereof and each of the parties hereto acknowledges that it has not entered into this Agreement in reliance on any representation or term not contained in this Agreement. This Agreement shall not be modified or varied except by a written instrument signed by the parties hereto.

18.3 The headings to the clauses in this Agreement are included for ease of reference only and are not part of this Agreement and are not to be taken into account in its construction.

18.4 The parties shall (and shall procure that any other necessary party within its control shall) execute and do all such documents acts and things as may be reasonably be required on or subsequent to completion of this Agreement for securing each of the obligations of the respective parties under this Agreement.

18.5 If this Agreement creates any rights which would in the absence of this provision be enforceable by any person not a party to this Agreement, such rights shall not be enforceable.

18.6 This Agreement shall be construed according to the laws of Ireland and the parties agree to submit to the jurisdiction of the Irish Courts.

Signed by:

Signed by:

\_\_\_\_\_  
**Duly authorised signatory on behalf of MCPSI**

\_\_\_\_\_  
**Duly authorised signatory on behalf of IMRO**

Name: \_\_\_\_\_

Name: \_\_\_\_\_

Position: \_\_\_\_\_

Position: \_\_\_\_\_

Date: \_\_\_\_\_

Date: \_\_\_\_\_

Signed by:

\_\_\_\_\_  
**Duly authorised signatory on behalf of the Licensee**

Name: \_\_\_\_\_

Position: \_\_\_\_\_

Date: \_\_\_\_\_

## SCHEDULE 1

### Definition of Music Service

"Broadcast"	<p>means an electronic transmission of visual images, sounds or other information which</p> <p>(a) is transmitted for simultaneous reception by members of the public and is capable of being lawfully received by them, or</p> <p>(b) is transmitted at a time determined solely by the person making the transmission for presentation to members of the public;</p> <p>and which is not excepted by subclause 1 and references to Broadcasting shall be construed accordingly.</p> <p>1. Excepted from the definition of "Broadcast" is any internet transmission unless it is:</p> <p>(i) a transmission taking place simultaneously on the internet and by other means,</p> <p>(ii) a transmission of recorded moving images or sounds forming part of a programme service offered by the person responsible for making the transmission, being a service in which programmes are transmitted at scheduled times determined by that person.</p> <p>For the avoidance of doubt the terms "broadcast" or "broadcasting" when used in this agreement without a capital "B" shall have the meaning given to them by the Act.</p>
"Excluded Service"	<p>means any service (or the relevant part of a service) which is a Podcasting Service or which falls within the scope (from time to time) of any of the following MCPSI/IMRO joint licensing schemes or any licensing schemes operated by IMRO or MCPSI:</p> <p>(a) IMRO – Ringtone/Ringback Licensing Scheme</p>



	<ul style="list-style-type: none"> <li>(b) MCPSI – Ringtone Licensing Scheme</li> <li>(c) MCPSI – Ringback Licensing Scheme</li> <li>(d) MCPSI – Karaoke and MIDI Scheme</li> <li>(e) MCPSI – Music-on-hold Scheme</li> <li>(f) MCPSI – Supply of Background Music Services Scheme</li> <li>(g) MCPSI – Premium Telephone Line Services Scheme</li> <li>(h) IMRO – Online Licensing Scheme – excluding Music Services and Ringtones</li> <li>(i) IMRO/MCPSI – Limited On-Line Exploitation Licensing Scheme</li> <li>(j) IMRO/MCPSI General Entertainment on Demand Licensing Scheme</li> </ul>
<p>“Limited Download / On-Demand Streaming Service “ or “LD/ODS Service”</p>	<p>means a service (or the relevant part of a service), other than an Excluded Service, whereby a User may receive a Musical Work by streaming on-demand via a Network (where the time and place at which such Musical Work is received is selected by the User) and/or may download via a Network that Musical Work but where such download may not be retained by the User on a permanent basis. Any service falling primarily within the foregoing definition but which also includes elements which fall within the definition of Premium and Interactive Webcasting Service and/or Pure Webcasting Service shall be deemed in its entirety to be a LD/ODS Service.</p>
<p>“Music Service”</p>	<p>means a service or the relevant part of a service which is:</p> <ul style="list-style-type: none"> <li>(a) a Permanent Download Service;</li> <li>(b) an LD/ODS Service;</li> <li>(c) a Premium and Interactive Webcasting Service;</li> <li>(d) a Pure Webcasting Service; or</li> </ul>

	(e) any combination of (a) to (d) above.
“Network”	means the internet, a mobile network or any other wired or wireless network.
“Permanent Download Service”	means a service (or the relevant part of a service), other than an Excluded Service, by which a Musical Work is made available to the public via a Network in the form of a download and where such download may be retained by the User on a permanent basis.
“Podcasting Service”	means a service (or the relevant part of a service) whereby “programmes” (as opposed to individual Musical Works) may be downloaded to Users’ Data Storage Devices (whether permanently or temporarily) and any tracks included within such programme cannot be disaggregated.
“Premium and Interactive Webcasting Service”	means a service (or the relevant part of a service), other than an Excluded Service, by which Musical Works are made available to the public via a Network and: <ul style="list-style-type: none"> <li>(a) no permanent or temporary copy of any Musical Work is retained by the User; and</li> <li>(b) such service is neither a Pure Webcasting Service, a Permanent Download Service, a LD/ODS Service or a Simulcast Service.</li> </ul>
“Pure Webcasting Service”	means a service (or the relevant part of a service), other than an Excluded Service or a Simulcast Service, by which Musical Works are Broadcast (as that term is defined in this Schedule 1) to Users via a Network. For the avoidance of doubt, to constitute a Pure Webcasting Service, there must be: <ul style="list-style-type: none"> <li>(a) no interactive functionality, for example (without limitation), no use of controls that enable the User to pause, skip, move forward or backwards through the stream;</li> <li>(b) no personalisation of the service by the User or the ability for the User to offer preferences which then dictate the tracks that are provided to that User, for example (without limitation), no ability for the User to rate tracks so as to</li> </ul>

	<p>influence subsequent tracks that are played;</p> <p>(c) no advanced notification to the User of titles of specific tracks to be played or specific albums from which tracks will be played (other than the introduction of the next track in DJ led services);</p> <p>(d) in any 3 hour period:</p> <p>(i) no more than 3 songs from a particular album (including no more than 2 consecutively);</p> <p>(ii) no more than 4 songs from a particular artist or from any compilation of tracks (including no more than 3 consecutively);</p> <p>(e) no archived programmes less than 5 hours in duration or available for more than 2 weeks; and</p> <p>(f) no continuous programmes of less than 3 hours duration; and</p> <p>(g) effective technologies, insofar as such technologies are commercially available and can be implemented without imposing unreasonable costs, which aim to prevent:</p> <p>(i) a User or any other person or entity from automatically scanning the Licensee's transmissions alone or together with transmissions by other transmitting entities in order to select a particular sound recording to be transmitted to the User; and</p> <p>(ii) a User from making copies, other than transient copies, of the sound recordings; and</p> <p>(h) no automatic or intentional cause by the Licensee of the device receiving a transmission to switch from one program channel to another.</p>
<p>"Simulcast Service"</p>	<p>means the Broadcast (as that term is defined in this Schedule 1) of a programme via a Network where such Broadcast:</p>

	<p>(a) is simultaneous with the Broadcast of such programme via a traditional terrestrial, satellite or cable television or radio service; and</p> <p>(b) is made from the website or other service of the originating Broadcaster.</p>
<p>“Special Webcasting Service”</p>	<p>means a Pure Webcasting Service or Premium and Interactive Webcasting Service where more than 50% of the sound recordings of the Musical works made available to the public (i) are by a single artist or band or (ii) comprise a live performance by a single artist or band with related performances by other artists and/or bands.</p>

## SCHEDULE 2

### Royalty Fee

#### 1. Definitions

“Applicable Revenue”	means the Gross Revenue less VAT (or other equivalent sales tax, as applicable).
“Limited Subscription Service”	means an LD/ODS Service whereby the User:  (a) pays to the Licensee a regular fee in order to access such service; and (b) gains access, only while such fee continues to be paid and controlled by appropriate DRM, to 20,000 different Musical Works or less.
“Minimum Royalties”	means the applicable minima set out in paragraphs 2.1(b), 2.2(b), 2.3(b), 2.4(b) and 2.5 (b) below.
“Mobile Licensed Service”	means a Licensed Service which is provided to Users and where, subject to paragraph 4.5 of schedule 3, the charge to the User for the Licensed Service includes all mobile network delivery charges applicable to the provision of such service.  References to Mobile Permanent Download Service, Mobile LD/ODS Service, etc. shall be construed accordingly.
“PC Subscription Service”	means an LD/ODS Service whereby the User: (a) pays to the Licensee a regular fee in order to access such service; and (b) gains access, only while such fee continues to be paid and controlled by appropriate DRM, to in excess of 20,000 different Musical Works; and (c) is able, only while such fee continues to be paid and controlled by appropriate DRM, to store and listen to Musical Works accessed through such service on a personal computer; and

	<p>(d) is unable to store and listen to Musical Works accessed through such service on a portable Data Storage Device (such as an mp3 or WMA player).</p>
<p>“Portable Subscription Service”</p>	<p>means an LD/ODS Service whereby the User:</p> <p>(a) pays to the Licensee a regular fee in order to access such service; and</p> <p>(b) gains access, only while such fee continues to be paid and controlled by appropriate DRM, to in excess of 20,000 different Musical Works; and</p> <p>(c) is able, only while such fee continues to be paid and controlled by appropriate DRM, to store and listen to Musical Works accessed through such service on a personal computer; and</p> <p>(d) is able, only while such fee continues to be paid and controlled by appropriate DRM, to store and listen to Musical Works accessed through such service on a portable Data Storage Device (such as an mp3 or WMA player).</p>
<p>“Subscriber”</p>	<p>means a User who is a subscriber to a PC Subscription Service, a Portable Subscription Service, a Limited Subscription Service or a Webcasting Subscription Service as the case may be.</p>
<p>“Subscription Permanent Download Service”</p>	<p>means a Permanent Download Service whereby the User pays to the Licensee a regular periodic fee in order to obtain permanent downloads.</p>
<p>“Webcasting Subscription Service”</p>	<p>means a Pure Webcasting Service or Premium and Interactive Webcasting Service (but not a Special Webcasting Service) whereby the User pays to the Licensee a regular fee in order to access such service.</p>

## 2. Royalty Fee

2.1 In respect of a Permanent Download Service the Royalty Fee per download shall be the higher of:

- (a) 8% of the Applicable Revenue; and
- (b) either (subject to (c) and (d) below):
  - (i) €0.0723 in respect of each Musical Work downloaded per download; or
  - (ii) if a Musical Work is downloaded as part of a bundle of eight to twelve (inclusive) Musical Works, €0.0603 in respect of each Musical Work downloaded.
  - (iii) if a Musical Work is downloaded as part of a bundle of thirteen to seventeen (inclusive) Musical Works, €0.0542 in respect of each Musical Work downloaded.
  - (iv) if a Musical Work is downloaded as part of a bundle of eighteen to twenty-nine (inclusive) Musical Works, €0.0422 in respect of each Musical Work downloaded.
  - (v) if a Musical Work is downloaded as part of a bundle of thirty or more Musical Works, €0.662 in respect of each Musical Work downloaded.
- (b) For the purposes of paragraph 2.1 (a) and (b) above, a collection of tracks shall only be considered a bundle if is (i) put together or otherwise approved by the relevant record company (or companies) or (ii) put together by the Licensee (provided permission of the owner of the relevant sound recording rights or artist (or artists) has been obtained and that the bundle is purchased as a whole. Collections of tracks assembled by Users are therefore not “bundles” for the purposes of paragraphs 2.1 (a) and (b).
- (d) Tracks which consist of either public domain Musical Works or non-music works (for example, spoken word) shall not be regarded as “tracks” for the purposes of counting the number of Musical Works in a bundle.
- (e) For the avoidance of doubt and for the purposes of paragraphs 2.1(b) (ii) to (v) above, by way of example, in respect of a bundle of 15 different sound recordings (including mixes) of the same Musical Work, the applicable Minimum Royalty for the whole of the bundle would be 67.5 cent.

- (f) Only one royalty (or one minimum, as applicable) shall be charged for so called “dual-downloads” where for a single price, the same track is delivered to a User’s PC and mobile device.
- (g) The parties shall discuss in good faith Minimum Royalties in respect of long and short tracks.
- (h) The Licensee shall be entitled to produce and include as part of a Licensed Service free audio-only or audio-visual clips of a Musical Work embodied in a sound recording of up to 30 seconds duration (or for “classical” genre up to one minute’s duration) without payment of any Minimum Royalty provided that such clip is used solely to promote the sale or other use of the Musical Work as part of the Licensed Service.

2.2 In respect of an LD/ODS Service (subscription), the Royalty Fee shall be the higher of:

- (a) 15% of the Applicable Revenue; and
- (b) either:
  - (i) where the Music Service is a Portable Subscription Service, €1.20 per Subscriber per Month; or
  - (ii) where the Music Service is a PC Subscription Service, €0.72 per Subscriber per Month; or
  - (iii) where the Music Service is a Limited Subscription Service, €0.35 per Subscriber per Month; or

2.3 In respect of an LD/ODS Service (other than by subscription), the Royalty Fee shall be the higher of:

- (a) 15% of the Applicable Revenue; and
- (b) €0.0015 per Musical Work made available to the public per User. For the avoidance of doubt, by way of example, a webcast of one Musical Work to 1000 Users incurs a Minimum Royalty of €1.50



- 2.4 In respect of a Special Webcasting Service (subscription) the Royalty Fee shall be the higher of:
- (a) 15% of the Applicable Revenue; and
  - (b) a Minimum Royalty per Subscriber per month to be negotiated between the parties in good faith.
- 2.5. In respect of a Special Webcasting Service (other than subscription) the Royalty Fee shall be the higher of:
- (a) 15% of Applicable Revenue: and
  - (b) €0.0014 per Musical Work made available to the public per User. In relation to the non subscriber based minimum, for the avoidance of doubt, by way of example, a webcast of one Musical Work to 1000 Users incurs a Minimum Royalty of €1.46.
- 2.6 In respect of a Premium and Interactive Webcasting Service (subscription), other than a Special Webcasting Service, it shall be the higher of:
- (a) 6.5% of the Applicable Revenue; and
  - (b) €0.39 per Subscriber per Month
- 2.7 In respect of a Premium and Interactive Webcasting Service (other than a Special Webcasting Service and other than subscription), it shall be the higher of:
- (a) 15% of the Applicable Revenue; and
  - (B) €0.0011 per Musical Work made available to the public per User. For the avoidance of doubt, by way of example, a webcast of one Musical Work to 1000 Users incurs a Minimum Royalty of €1.08
- 2.7 In respect of a Pure Webcasting Service (subscription),(other than a Special Webcasting Service, it shall be the higher of:
- (a) 15% of the Applicable Revenue; and
  - (b) €0.35 per Subscriber per Month
- 2.8 In respect of a Pure Webcasting Service (other than a Special Webcasting Service and other than subscription), it shall be the higher of:

- (a) 15% of Applicable Revenue: and
- (b) €0.0008 per Musical Work made available to the public per User. For the avoidance of doubt, by way of example, a webcast of one Musical Work to 1000 Users incurs a Minimum Royalty of €0.84.

2.9 For the avoidance of doubt, the calculation leading to the Royalty Fee for a particular download, subscription or stream being either (a) or (b) above (in each of paragraphs 2.1 to 2.8 above, as applicable) shall be carried out individually in respect of each download, subscription or stream (as applicable) to each User and then the Royalty Fees, calculated on that basis, for all downloads, subscriptions or streams (as applicable) to all Users shall be added together in order to calculate the full Royalty Fees due. For the purposes of the foregoing calculation, where there is any Gross Revenue arising which is not attributable to a particular download, subscription or stream (for example, revenue arising from advertising or sponsorship etc), this shall be apportioned equally between all downloads, subscriptions or streams (as applicable).

### **3. Bundling**

- 3.1 Where a Music Service (for the purposes of this clause “Service A”) is provided to Users in conjunction with a service which is not a Music Service (for the purpose of this clause “Service B”), then the price deemed to be payable by Users (“the User Price”) for the Music Service (for the purpose of calculating Gross Revenue) shall be calculated in accordance with this paragraph 3.
- 3.2 Where there are separate published prices for Service A and Service B when available alone, then the User Price shall be the proportion of the bundled price represented by the relative standalone prices for Service A and Service B.
- 3.3 Where there are no separate published prices for Service A and Service B, then the User Price shall be deemed to be the proportion of the bundled price represented by the relative standalone prices for comparable Irish services for Service A and Service B. If there is more than one comparable service, then the average shall be used.
- 3.4 If there are no comparable Irish standalone services for Service A and Service B, then the applicable Minimum Royalties shall be payable.
- 3.5 For the avoidance of doubt, where the User Price is set according to either of paragraphs 3.2 and 3.3 above, the royalty payable shall be the higher of the applicable royalty rate applied to the User Price and the applicable Minimum Royalty.

#### **4. Promotional Use**

- 4.1 Provided that the owner of the copyright in the sound recording has agreed to allow the Licensee to make the sound recording available for free to Users of its Music Service and that such owner is not entitled to payment of any royalty or any other consideration whether in monetary form or otherwise in relation to such use, the Licensors shall permit Musical Works incorporated in such sound recordings to be made available for free to Users and no royalty shall be due under the Agreement in relation to such use on the terms set out in this paragraph 4, but not otherwise:
- 4.2 For a paid for PC Subscription Service, Limited Subscription Service, Portable Subscription Service and Webcasting Subscription Service, the Licensee may provide such Licensed Service to each User for free for 2 weeks as a one-off introductory discount.
- 4.3 For a paid for Subscription Permanent Download Service, the Licensee may provide such Licensed Service to each User for free for 2 weeks as a one-off introductory discount provided that the User is limited during this period to accessing no more than ten (10) Permanent Downloads of Musical Works for free.
- 4.4 For a Permanent Download Service (other than a Subscription Permanent Download Service) that has annual Gross Revenue exceeding eight hundred thousand euro (€800,000) but less than eight million euro (€8,000,000) (excluding VAT) calculated by reference to the four preceding full quarters' reporting data, the Licensee may make available to Users at any one time up to two (2) Permanent Downloads of Musical Works for free provided that:
- (a) such promotional usage is solely to promote sales of paid-for Permanent Downloads of Musical Works by the same artist/band or songwriter as the Permanent Download of the Musical Work being made available for free;
  - (b) the length of time that any one Permanent Download of a Musical Work is made available to Users for free is limited to one period of no more than thirty (30) days;
  - (c) any vouchers issued in relation to such promotional usage must be redeemed by Users within thirty (30) days of their first distribution; and
  - (d) the publisher(s) owning the rights to the Musical Work has/have granted prior written consent to such use.
- 4.5 For a paid for Permanent Download Service that has annual Gross Revenue exceeding eight million euro (€8,000,000) (excluding VAT)

calculated by reference to the four preceding full quarters reporting data, the Licensee may make available to Users at any one time up to five (5) Permanent Downloads of Musical Works for free provided that it satisfies each of the terms set out in paragraphs 4.4 (a) to (d) above.

- 4.6 For the avoidance of doubt, where prior written consent of the publisher (s) owning the rights to the Musical Work is required pursuant to paragraphs 4.4(d) and 4.5, the Licensors shall put in place reasonable procedures to seek to ensure that such consent is granted or withheld within five (5) working days of the Licensee's written request, and if such consent is provided by the publisher(s), then the Licensors shall forthwith provide any additional consents in relation to such use of the rights which they or either of them administer.
- 4.7 For the avoidance of doubt, the Licensee may without restriction make the Licensed Services available for free over and above the limits set out in paragraphs 4.1 to 4.6 above, but the applicable Minimum Royalties shall apply in respect of any free access or downloads over and above such limits.
- 4.8 Insofar as any particular music publisher shall request that the promotional allowances set out above should be exceeded for the purposes of a specific promotion, the Licensors shall consider such request in good faith.

## **5. Provision of Music Services to Users outside Ireland**

Without prejudice to the territorial restrictions set out in this Agreement (and, for the avoidance of doubt, subject to the availability of the repertoire), where this Agreement is to cover the accessing by Users of the Licensed Service(s) from outside Ireland, then the Licensee acknowledges that the Licensors may require that the royalties payable in respect of the Licensed Service(s) being accessed outside Ireland shall be calculated on the basis of the rates at that time published as applying in the additional countries in question. If the Licensors require such rates to be payable and the Licensee does not agree to pay on the basis of those rates, then it may not be possible for this Agreement to cover the availability of the Licensed Service(s) outside Ireland. The Licensors and Licensee shall discuss such issues in good faith, but if no agreement can be reached by such time as either party may decide at its discretion, then that party may terminate this Agreement (only in respect of the availability of the Licensed Services outside Ireland) by giving the other party one month's written notice.

**SCHEDULE 3**  
**Definition of Gross Revenue**

**“Gross Revenue”**

means, subject to the provisions of this Schedule:

- (a) all revenue received (or receivable) by the Licensee from Users in consideration for the provision of the Licensed Services; and
- (b) all revenue, including by way of sponsorship and commissions, received (or receivable) by the Licensee as a result of the inclusion of third party advertising “in-stream” or “in-download” as part of the Licensed Service, being advertising placed immediately at the start, end or during the actual delivery (by way of streaming or downloading as applicable) of a Repertoire Work to a User; and
- (c) all revenue, including by way of sponsorship and commissions, received (or receivable) by the Licensee as a result of the placement of third party advertising on a Relevant Page (as defined below) of the Licensed Service (and including any page which directly follows such Relevant Page leading up to and including the downloading or streaming of the music offering);

and in each of the above cases such revenue shall, for the avoidance of doubt, include any such revenue whether received or receivable by the Licensee or any associate, affiliate, agent or representative of such party.

Subject to the remainder of this schedule 3, there shall be no other deduction or set-off from the above revenues other than refunds to Users for services that they were unable to use due to technical faults in the Licensed Services.

**“Relevant Page”**

means a page:

- (a) from which Licensed Services are “actually offered” to Users. A Licensed Service is “actually offered” to Users from a page if Musical Works are enabled or made directly available from that Licensed Service to the User to download or stream from that page (in most cases this will be where such Musical Works can be purchased by the

User or their download or stream otherwise takes place); but only

- (b) where such offering forms all or the predominant part of that page, being for the purposes of this Agreement where the offering comprises 75% or more of the space on that page excluding space occupied by any advertising. For the purposes of performing the foregoing calculation, the "offering" shall include any content which directly relates to the actual offering of the Licensed Service pursuant to sub-paragraph (a) above (by way of example, but without limitation, an image of the artist or artwork closely associated with the offering, reviews of the offering, credits, and music player controls).

Where more than one type of Music Service is actually offered from a Relevant Page, for the purpose of determining which Royalty Rate applies, any advertising revenue included in Gross Revenue shall be apportioned between such Music Services on the basis of the proportion of the page that they occupy.

## **1. General**

- (a) For the avoidance of doubt, the definition of Gross Revenue above shall be applied in conjunction with the provisions on bundling set out in paragraph 3 of schedule 2. The Licensors confirm that no revenue which is included in Gross Revenue under this Agreement shall form any part of the "revenue base" under any other licence or licensing scheme operated by the Licensors (or either of them) which grants all or some of the rights set out in clauses 2.1 and 2.2 of the main body of this Agreement (albeit in relation to a service which is not a Licensed Service hereunder).
- (b) For the further avoidance of doubt, revenue which relates solely to services other than the Licensed Service shall not be included in the Gross Revenue. By way of example, this includes:
  - (i) revenue derived from non-music voice, content and text services;
  - (ii) revenue derived from music or music-related services which is/are not a Music Service (including without limitation any ringtones services);

- (iii) revenue derived from non-music products and services (including search services) supplied by the Licensee.
- (c) For the further avoidance of doubt, Gross Revenue shall not be reduced by credit card commissions or similar payment process charges.

## **2. Advertising and Sponsorship Revenue**

- (a) Gross Revenue obtained in the form of advertising or sponsorship revenue shall be reduced by 5% to reflect the costs of obtaining it.
- (b) For the avoidance of doubt, advertising revenue referred to in sub-paragraph (b) of the definition of Gross Revenue above shall not include revenue arising from sponsored searches or click-through commissions arising from such searches.

## **3. Audio-Visual**

- (a) Prior to the Date of Convergence (as defined below), Gross Revenue generated in relation to the use of Repertoire Works in Audio-Visual Material shall be discounted by 15%.
- (b) If and when Convergence has been reached shall be assessed by the Licensors using reporting data submitted to it and this shall then be notified to the Licensee.
- (c) "Convergence" means the aggregate number of unit sales in Ireland of Permanent Downloads in the form of Audio-Visual Material licensed under this Agreement is the same or greater than the aggregate number of unit sales in Ireland of Permanent Downloads during any period of three Months prior to or ending on 31 December 2009 calculated by reference to not less than 80% of the units of each form of Permanent Download sold and the "Date of Convergence" means the last date of that three Month period. The Licensors shall use reasonable endeavours to inform the Licensee from time to time of the anticipated Date of Convergence.
- (d) For the avoidance of doubt, the discount set out in this clause 3 applies only to Gross Revenue and the Minimum Royalties shall not be reduced in relation to Repertoire Works in Audio-Visual Material licensed under this Agreement.

#### **4. Mobile Delivery**

4.1 In relation to Mobile Licensed Services, for the purpose of calculating Gross Revenue under this Agreement, then, subject to paragraphs 4.2 to 4.5 below, the price paid by the User shall be reduced by:

- (a) 15% for Mobile Permanent Download Services; or
- (b) 7.5% for all other Mobile Licensed Services.

4.2 The reduction referred to in paragraph 4.1 (a) above will:

- (a) no longer apply, in relation to Mobile Permanent Download Services, from the point in time when the price of such downloads converges to 117.65% or less than the weighted standard average price of downloads (of a similar type) obtained from other Permanent Download Services. This will be deemed to have taken place when the weighted average sales price of downloads (of a similar type) obtained from Mobile Permanent Download Services operated by the top 3 (by royalty value paid to the Licensors in the previous 4 Quarters) Irish mobile network operators in a given Quarter is 117.65% or less than the weighted standard average price of downloads obtained from the top 3 (by royalty value paid to the Licensors in the preceding 4 Quarters) other Permanent Download Services for the same Quarter; or
- (b) not apply, in relation to a particular download obtained from a Mobile Download Service, if the retail price of that download is 117.65% or less than the weighted standard average price of a similar type of download obtained from other Permanent Download Services (to be calculated as set out in clause 4.2(a) above).

4.3 The reduction referred to in paragraph 4.1(b) above will no longer apply for a particular Mobile Licensed Service where the retail price of that service is 117.65% or less than the weighted standard average price of the top 3 (by royalty value paid to the Licensors in the preceding 4 quarters) equivalent Music Services (which are not Mobile Licensed Services) in the preceding Quarter

4.4 For the avoidance of doubt, for the purpose of paragraphs 4.1(b) and 4.3 above, where a Mobile Licensed Service is launched at a price point that means that it does not qualify for the reduction under paragraph 4.1(b) above, if the relative price of that service and the non-mobile services referred to in paragraph 4.3 change to the extent that it would subsequently qualify for the reduction, then it shall be entitled to the reduction in paragraph 4.1(b) above until such time as the threshold in paragraph 4.3 above is reached again.



- 4.5 Where content and delivery charges for music are quoted separately for a Mobile Music Service, then the royalty charged for the provision of such music shall be the equivalent amount to the royalty charged to that Licensee when the content and delivery charges for equivalent music products are quoted as a single price. Where the Licensee does not provide equivalent music products on the basis that content and delivery prices are quoted as a single price, then such provision of music shall be excluded from this Agreement and royalty terms shall be subject to a separate discussion in good faith between the parties.
- 4.6 All references in this paragraph 4 to prices shall be deemed to be excluding VAT or other equivalent sales taxes.

## **5. Vouchers**

- 5.1 This paragraph 5 applies only to a Licensee which runs a voucher scheme where each issued voucher ("the Voucher"):
- (a) is issued in conjunction with a festival or other musical event, and the voucher contains no branding other than that of the Licensee, the band/artist performing at the festival or other musical event, and/or the festival or other musical event; or
  - (b) does not refer to any specific artist(s), band(s) or Musical Work(s).

Repertoire Works provided via a Voucher scheme which is outside this paragraph 5.1 are not licensed under this Agreement and a separate licence for premium usage of this type must be sought from the Licensors.

- 5.2 The price of each Voucher, calculated in accordance with paragraph 5.3, below shall be included in Gross Revenue if and to the extent that it is redeemed by a User or Users.
- 5.3 The price of each Voucher shall be calculated as follows:
- (a) Where the Voucher does not contain any branding or no branding other than (i) that of the Licensee for the Licensed Service, (ii) that of a third party ordinarily engaged in the sale of vouchers to Users or (iii) as permitted under paragraph 5.1(a) above, the price shall be the price charged to each User.
  - (b) Except as set out in (a) above, where the Voucher contains branding of a third party (which includes for the purposes of this paragraph 5.3(b) an entity in the same corporate group as the Licensee) and/or is distributed as part of a promotion by a third party, the price shall be deemed to be the full usual retail price

charged by the Licensee for the Music Service to which the Voucher relates.

**SCHEDULE 4**

**Online Music Services**

**Music Usage Information Reporting Format**

# Online and Mobile Music Services

## Music Usage Information Reporting Format

### MCPSI-IMRO ONLINE Format Specification

#### Version 2.1

## Table of Contents

<b>1</b>	<b>Overview</b>	<b>52</b>
<b>2</b>	<b>Report Structure</b>	<b>52</b>
2.1	Audio Release Report .....	52
2.2	Audiovisual Release Report .....	53
2.3	User Uploaded Content Report .....	54
<b>3</b>	<b>File Header Data Fields</b>	<b>56</b>
<b>4</b>	<b>Audio Release Details Data Fields</b>	<b>58</b>
<b>5</b>	<b>Audio Track Details Data Fields</b>	<b>59</b>
<b>6</b>	<b>Audiovisual Release Details Data Fields</b>	<b>60</b>
<b>7</b>	<b>Music Cue Details Data Fields</b>	<b>61</b>
<b>8</b>	<b>User Uploaded Content Data Fields</b>	<b>62</b>
<b>9</b>	<b>Usage Details Data Fields</b>	<b>63</b>
<b>10</b>	<b>File Trailer Fields</b>	<b>64</b>
<b>11</b>	<b>Character Separated Version Specification</b>	<b>68</b>
<b>12</b>	<b>Fixed File Format Specification</b>	<b>69</b>
<b>13</b>	<b>Document Control</b>	<b>77</b>

## Figures

Figure 1:	Organisation of Record Types in an Audio Release Report .....	53
Figure 2:	Organisation of Record Types in an Audiovisual Release Report .....	54
Figure 3:	Organisation of Record Types in a User Uploaded Content Report .....	55

## Tables

Table 1:	Applicable IREJOL Service Definitions .....	67
----------	---	----

## Overview

The Music Usage Information Report is used to report On-line Music Usage in audio releases, audiovisual releases or user uploaded content on User Generated Content websites. It is designed to accommodate the reporting of music associated with online and mobile services and any 'non-linear' transmissions that are not organised around a pre-determined time schedule.

This report is capable of describing the following details relating to the music Usage, including:

- Revenue Details
- Audio or Audiovisual Release Details
- Recording Details
- Musical Work details (including work title, writers and publishers)
- User Uploaded Content Details
- Price Details
- Usage Totals
- Usage Territories

The data can be delivered as a report in either a CSV Pipe delimited format or as a fixed length field format. See sections 10 and 11 of this document for further details of the specifications for each format.

## Report Structure

There are eight record types designed to include information for music reporting purposes:-

<u>Type</u>	<u>Record Name</u>
00	File Header
10	Audio Release Details
11	Audio Track Details
15	Audiovisual Release Details
16	Music Cue Details
19	User Uploaded Content
20	Usage Details
99	File Trailer

The following sections explain how these record types are combined within three separate reports depending on the context in which the music is being used. Each service requires a separate file. Licensees cannot compile data for more than one service into one file when reporting. This is because the Service Type forms a part of the File Header (Field 11).

### Audio Release Report

**For the supply of music usage details in an audio release** (including music videos) the following **five** record types **must** be completed:

<u>Type</u>	<u>Record Name</u>
00	File Header
10	Audio Release Details
11	Audio Track Details

20 Usage Details  
 99 File Trailer

The organisation of these record types is illustrated in the following diagram:

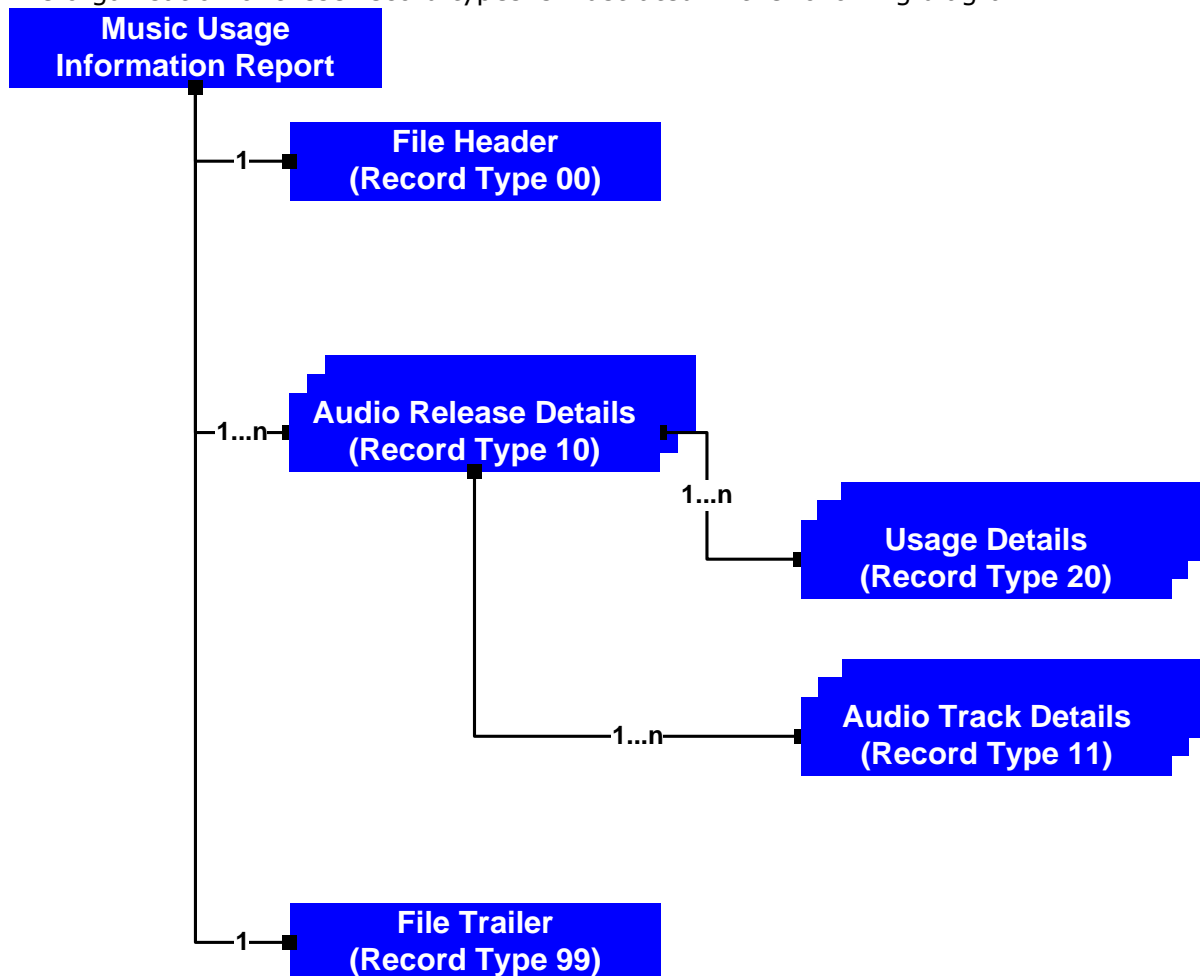

**Figure 1: Organisation of Record Types in an Audio Release Report**

## Audiovisual Release Report

**For the supply of music usage details in an audiovisual release** (such as television productions and feature films) the following **five** record types **must** be completed:

<u>Type</u>	<u>Record Name</u>
00	File Header
15	Audiovisual Release Details
16	Music Cue Details
20	Usage Details
99	File Trailer

The organisation of these record types is illustrated in the following diagram:

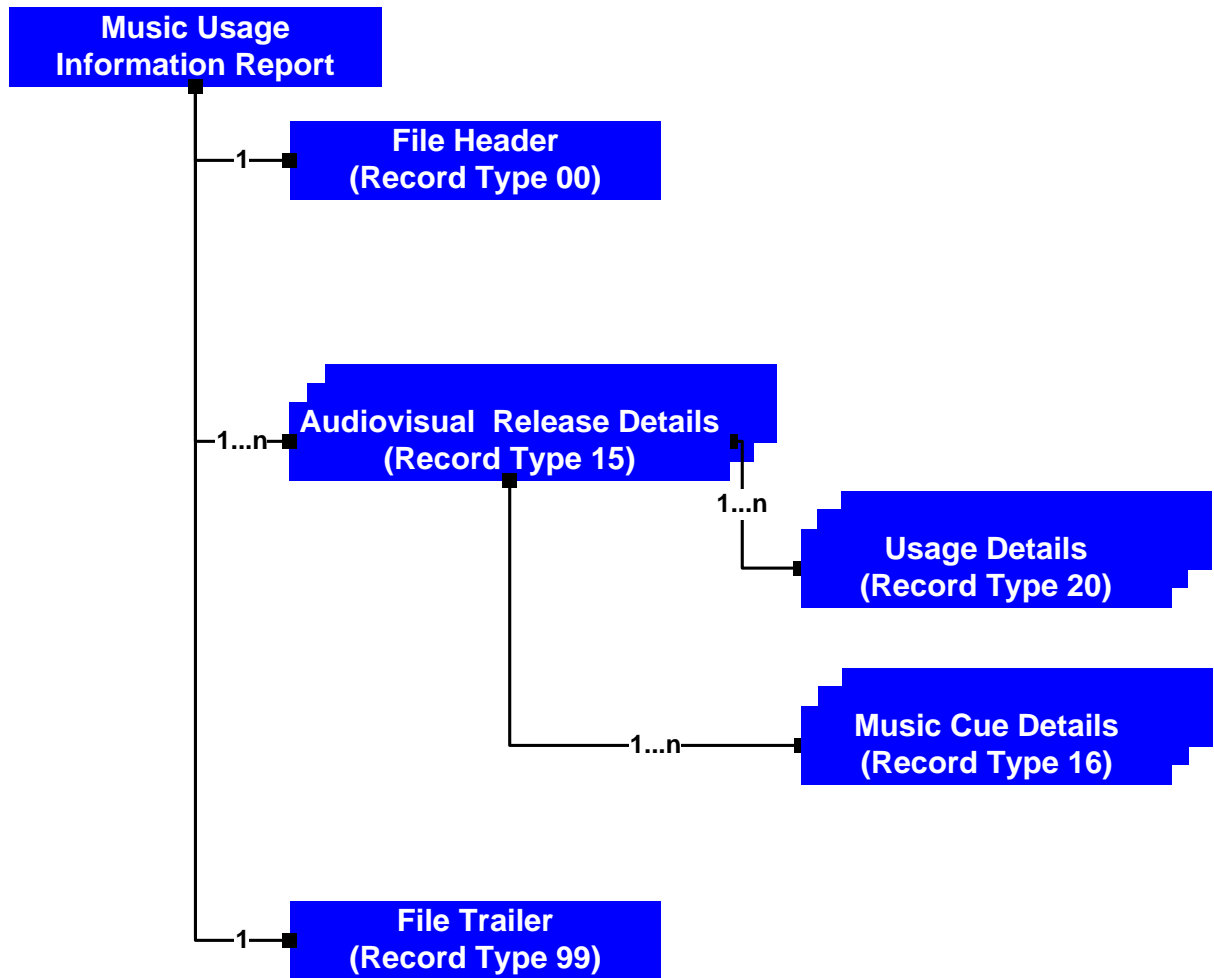

**Figure 2: Organisation of Record Types in an Audiovisual Release Report**

## User Uploaded Content Report

**For the supply of music usage details in user uploaded content** (such as video content created or compiled by a user of a social networking site and uploaded for others to view) the following **four** record types **must** be completed:

<u>Type</u>	<u>Record Name</u>
00	File Header
19	User Uploaded Content Details
20	Usage Details
99	File Trailer

The organisation of these record types is illustrated in the following diagram:

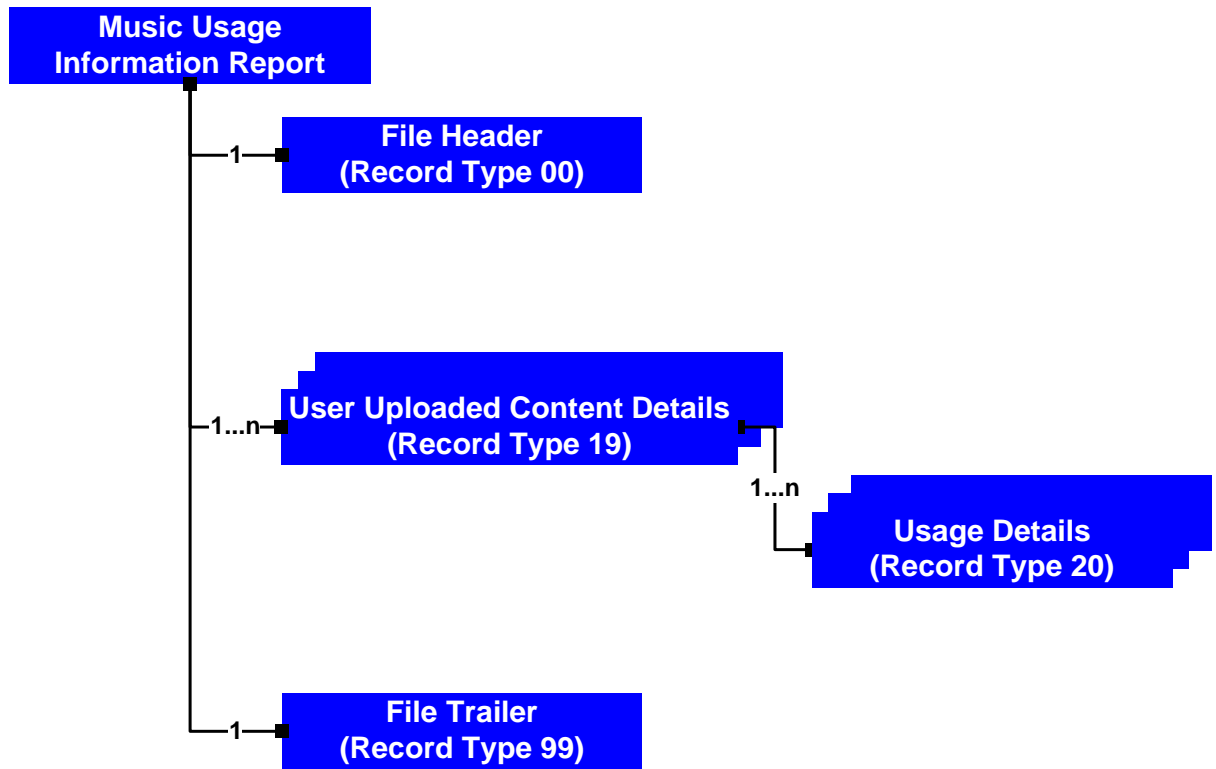

**Figure 3: Organisation of Record Types in a User Uploaded Content Report**



## File Header Data Fields

The **record type 00** marks the beginning of the file and contains high-level Licensing and Usage data for the Service within the Reporting Period.

The letters in brackets confirm whether or not the supply of the information is Mandatory **[M]**, Conditional **[C]** or Optional **[O]**. A Conditional field may be Mandatory depending on the other fields completed and the type of service.

The File Header record contains the following fields:

- 1) **Record Type [M]** -Value of "00" which identifies the record as the File Header Record
- 2) **Format [M]** - Indicates the file format. A value of "JOLS" identifies the file as a Joint Online Sales file.
- 3) **Version [M]** - Indicates which version of the file format has been used [Format=N.N] (e.g. 2.1)
- 4) **Extract Date [M]** - The date the Usage Reporting File was produced by the Reporting Company. [Format=CCYYMMDD]
- 5) **Reporting Company Name [M]** - Name of company providing the Usage Data - Licensee's Name
- 6) **Trading Name [O]** - Brand Name of Reporting Company (if different from Reporting Company Name). This will apply if the licensee has chosen to trade under a different trading name for that service.
- 7) **Supplier Number [O]** - The Reporting Company's identifier with the Licensing Body. *This identifier will be assigned by MCPSI -IMRO during the licencing process.*
- 8) **Purchase Order Number [O]** - The Purchase Order Number which must be associated with the invoice for the usage reported.
- 9) **Reporting Period Start Date [M]** - The start date of the period the Usage data relates to. [Format=CCYYMMDD]
- 10) **Reporting Period End Date [M]** - The start date of the period the Usage data relates to. [Format=CCYYMMDD]
- 11) **Service Type [M]** - A code which classifies how the Online Service operates for the given licensing scheme. The allowed values are:

Service Type	Definition	Licensing Scheme		
PDS	Permanent Download Service	IRE JOL	CELAS	
LDS	Limited Download / On Demand Streaming Service	IRE JOL		
PIW	Premium and Interactive Webcasting Service	IRE JOL		
PWS	Pure Webcasting Service	IRE JOL		
LSS	Limited Subscription Service	IRE JOL		
PCS	PC Subscription Service	IRE JOL		
PSS	Portable Subscription Service	IRE JOL		
SPD	Subscription Permanent Download Service	IRE JOL		
WSS	Webcasting Permanent Download Service	IRE JOL		

SWS	Special Webcasting Service	IRE JOL		
<b>RTS</b>	Ringtone Service	MCPSI	IMRO	
<b>RSS</b>	Ringtone Service Subscription	MCPSI	IMRO	
<b>RBS</b>	Ringback Service	MCPSI	IMRO	
<b>RBU</b>	Ringback Service – Subscription	MCPSI	IMRO	
<b>POS</b>	Podcast Service	MCPSI	IMRO	
<b>UGC</b>	User Generated Content			UGC

See Table 1 in this document for definitions of the IREJOL service types

- 12) **Additional Direct Revenue [C]** – Additional revenue related directly to the Usage of the Releases but not reported at track level (Record 20). If there is no Additional Direct Revenue or if the total applicable revenue for each Release has been reported on the Usage detail record (on Record 20) then "0.00" must be provided. If the revenue as a whole or part thereof is not related to track usage (eg: members fees or subscription) the amount of said revenue should be detailed in that field. Please note this is not a total revenue entry, it should not add up to the total of each usage. [Format = 999999999.99]
- 13) **Indirect Revenue Advertising [M]** – Revenue related to advertising revenue for the Service. If there is no advertising Revenue then "0.00" must be provided. [Format = 999999999.99].
- 14) **Indirect Revenue Other [M]** – Revenue related to other indirect revenue for the Service, such as subscription fees. If there is no other indirect revenue for the Service then "0.00" must be provided. [Format = 999999999.99].
- 15) **Revenue Currency [M]** – The ISO 4217 Currency Code (3 alpha code) which identifies the currency of the revenue amounts.  
<http://www.xe.com/iso4217.php>
- 16) **Total Number of Subscriptions [C]** – If reporting monthly, the total number of subscribers in the month. If reporting quarterly, the sum of the total subscribers each month. This information is mandatory for subscription based Services. [Format = 999999999].
- 17) **Mobile Service Flag [O]** – Indicates if the Service is classified as a Mobile Service and thereby potentially eligible for the 'Mobile Discount' as decided by the specific terms of each license. This only applies to Mobile Services providers. For further information about the definition of "Mobile Services", please consult your Online Licensing consultant. [Format = Y or N].

**Note: Validation Rule for fields 12, 13 and 14**

Where revenue data is provided in the File Header record type 00 (and the revenue value is greater than 0.00) all Usage Detail record type 20's in the file must apply to the same territory. Where revenue is being provided for multiple territories a separate file will need to be provided for each territory.

Where revenue is provided in the Usage Detail record type 20, a different territory may be reported in each occurrence of the Usage Detail record.

**Note: Validation Rule for field 16**

Where revenue data is provided in the File Header record type 00 for a subscription service (and the revenue value is greater than 0.00) all Usage Detail record type 20's in the file must apply to the same territory. Where

revenue for a subscription service is being provided for multiple territories a separate file will need to be provided for each territory.

## Audio Release Details Data Fields

The **record type 10** contains details of the Release (bundles of works). This record type will be used to report information about releases of sound recordings and, where applicable, music videos. There will be one record of this type for each Release which is sold as an individual unit. Detailed about the recording(s) and work(s) contained in each release will be reported in the following record type 11.

The letters in brackets confirm whether or not the supply of the information is Mandatory [**M**], Conditional [**C**] or Optional [**O**]. A Conditional field may be Mandatory depending on the other fields completed and the type of service.

The Release Details record contains the following fields

- 1) **Record Type [M]** -Value of "10" which identifies the record as the Release Detail Record.
- 2) **Reporting Company ID [M]** - The Reporting Company's unique identifier for the Release.
- 3) **Multi-Track Release Indicator [M]** - Indicates if the Release consists of a multiple or single tracks ("M"=Multi-Track, "S"=Single Track)
- 4) **Customised Release Indicator [C]** - Indicates that the tracks contained in a release have been selected by a consumer and therefore the release has been customised. This indicator is mandatory where the Multi-Track Release Indicator is **M**. The values are: **Y** = Yes; **N** = No.
- 5) **Release Title [M]** - The Title of the Release.
- 6) **Featured Artist [O]** - Names of artist(s) associated with the Release. If several artists feature on one track, please separate using a backward slash (\). This field cannot be greater than 80 characters, please feature the main artists first, and trim as necessary.
- 7) **Release/Record Catalogue Number [O]** -The Catalogue Number of the original Release from the track or tracks have been taken.
- 8) **Original Issue Date of Release [O]** - The date when the Release was originally issued. If the Release was previously issued on physical media then this field should contain the issue date of the physical product.
- 9) **Total Release Duration [O]** - The total duration of the Release including non-Music items. The format shall be MMMSS. For example: 011737 not 11737 (one hundred and seventeen minutes, thirty seven seconds).

## Audio Track Details Data Fields

The **record type 11** contains details of the works which are used within an Audio Release. There will be one record of this type for each work that is used,

The letters in brackets confirm whether or not the supply of the information is Mandatory **[M]**, Conditional **[C]** or Optional **[O]**. A Conditional field may be Mandatory depending on the other fields completed and the type of service.

The Audio Track Details record contains the following fields

- 1) **Record Type [M]** –Value of “11” which identifies the record as the Audio Track Detail Record.
- 2) **Reporting Company ID [M]** – The Reporting Company’s unique identifier for the Release. This must be the same as the Production Identifier contained on the associated **Audio Release Details** record.
- 3) **Reporting Company Track Identifier [O]** – The Reporting Company’s unique identifier for the track within the Release (this may be the same as the Reporting Company’s Release Identifier for single track products).
- 4) **Work Identifier [O]** – Either the Tunecode of the Work or the ISWC.
- 5) **Recording ISRC [O]** –The ISRC of the Recording.
- 6) **Track Title [M]** – Title of the Track. This is normally the same as the title of the Musical Work.
- 7) **Featured Artist [M]** – Names of artist(s) responsible for performing the work/recording. If several artists feature on one track, please separate using a backward slash (\). This field cannot be greater than 80 characters, please feature the main artists first, and trim as necessary.
- 8) **Writer [C]** –The names of the composer, authors or arrangers of the Musical Work. If several writers exist on the same musical work, please separate using a backward slash (\).This field cannot be greater than 80 characters, please feature the main writers first and trim as necessary. **Mandatory if Work Identifier is not supplied.**
- 9) **Publisher [C]** – The names of publisher(s) of the Work. If several publishers feature on one track, please separate using a backward slash (\). This field cannot be greater than 80 characters, please feature the main publishers first, and trim as necessary. **Mandatory if Work Identifier is not supplied.**
- 10) **Music Duration [M]** – For music only items, this will be the full duration of the recording. If audio-visual items, (E.g. an interview with the band) this will be the duration of the individual track used within the audio-visual item. The format shall be MMMMSS. For example: 000137 not 137 (one minute, thirty seven seconds).
- 11) **Original Issue Date of Recording [O]** – The date then the recording was first issued as part of Release.
- 12) **Music Video Indicator [O]** – Set to “Y” if the track is a music video.
- 13) **Non-Music Flag [O]** – Must be “Y” if item is a non-Music Item, such as a Spoken Word track.

# Audiovisual Release Details Data Fields

The **record type 15** contains details about the release of an audiovisual production. This record type will be used to report information about releases of television programmes, feature films and where applicable, advertisements and promos. All of the music cues relating to each audiovisual production will be reported in the following record type 16.

The letters in brackets confirm whether or not the supply of the information is Mandatory **[M]**, Conditional **[C]** or Optional **[O]**. A Conditional field may be Mandatory depending on the other fields completed and the type of service.

The Production Details record contains the following fields:

- 1) **Record Type [M]** – Value of “15” which identifies the record as the Production Detail Record.
- 2) **Reporting Company Identifier [M]** – This is the Reporting Company’s unique identifier assigned to the production. For IRE television commercials this can be the Clock Number.
  - a) **Society Production Identifier [O]** – This is the unique identifier assigned to the production by the Society receiving the Reporting Company’s release details.
- 3) **ISAN [O]** – The International Standard Audiovisual Number assigned to the production.
- 4) **Production Name [M]** – This is the name of the production or commercial.
- 5) **Series Indicator [M]** – This indicator is used to show whether the production is part of a series. The Values are **Y** = Part of A Serie or **N** = Not Part of A Serie
- 6) **Episode Number [C]** – This is the number of the Episode. This information is mandatory where the Series Indicator is **Y**.
- 7) **Episode Name [C]** – This is the name of the Episode. This information is mandatory where the Series Indicator is **Y**.
- 8) **Production Indicator [M]** – This indicator is used to describe the type of production being reported. The values are: **P** = Promo/Trailer; **N** = Programme; **F** = Feature Film; **C** = Commercial.
- 9) **Year of Production [C]** – The year in which the production was produced. This information is mandatory where the Production Indicator is **F**.
- 10) **Music Content Indicator [M]** – This indicator is used to describe the status of the music used in the production. The values are: **Y** = Contains music; **N** = Contains no music; **S** = Cue sheet previously supplied.
- 11) **Production Company Name [O]** – The name(s) of the production company(s) that created the production.

## Music Cue Details Data Fields

The **record type 16** contains details about the music cues contained in the audiovisual production described in record type 15. All of the music cues relating to each audiovisual production must be reported. Unless the Society Production Identifier has been provided in record type 15 (see Section 6 Audiovisual Release Details Data Fields) the Reporting Company will be required to provide details about all of the music cues contained in the audiovisual production.

The letters in brackets confirm whether or not the supply of the information is Mandatory **[M]**, Conditional **[C]** or Optional **[O]**. A Conditional field may be Mandatory depending on the other fields completed and the type of service.

The Music Details record contains the following fields:

- 1) **Record Type [M]** –Value of “16” which identifies the record as the Music Detail Record.
- 2) **Reporting Company Identifier [M]** – This is the Reporting Company’s unique identifier assigned to the production. This must be the same as the Production Identifier contained on the associated **Audio Visual Release Details** record.
- 3) **Work Identifier [O]** – Either the Tunecode or the ISWC assigned to the Work.
- 4) **Recording ISRC [O]** –The ISRC of the Recording.
- 5) **Music Cue Title [M]** – Title of the music cue. This is normally the same as the title of the Musical Work.
- 6) **Featured Artist [M]** – Names of artist(s) responsible for performing the work/recording. If several artists feature on one track, please separate using a backward slash (\). This field cannot be greater than 80 characters, please feature the main artists first, and trim as necessary.
- 7) **Writer [C]** –The names of the composer, authors or arrangers of the Musical Work. If several writers feature on one track, please separate using a backward slash (\). This field cannot be greater than 80 characters, please feature the main writers first, and trim as necessary. **Mandatory if Work Identifier is not supplied.**
- 8) **Publisher [C]** – The names of publisher(s) of the Work. If several publishers feature on one track, please separate using a backward slash (\). This field cannot be greater than 80 characters, please feature the main publishers first, and trim as necessary. **Mandatory if Work Identifier is not supplied.**
- 9) **Music Duration [M]** – For music only items, this will be the full duration of the recording. If audio-visual items, (E.g. an interview with the band) this will be the duration of the individual track used within the audio-visual item. The format shall be MMMSS. For example: 000137 not 137 (one minute, thirty seven seconds).
- 10) **Library Work Indicator [M]** – This indicator is used to show whether the music cue has been taken from a production music library. The values are: **Y** = Yes; **N** = No.

## User Uploaded Content Data Fields

The **record type 19** contains details about the music contained in the audiovisual content uploaded on User Generated Content sites. This record type is specifically for the description of content that cannot be described in the preceding audio and audiovisual release record types.

The letters in brackets confirm whether or not the supply of the information is Mandatory **[M]**, Conditional **[C]** or Optional **[O]**. A Conditional field may be Mandatory depending on the other fields completed and the type of service.

The Music Details record contains the following fields:

- 1) **Record Type [M]** –Value of “19” which identifies the record as the Music Detail Record.
- 2) **Reporting Company Identifier [M]** – This is the Reporting Company’s unique identifier assigned to the uploaded content.
- 3) **URL [M]** – the Uniform Resource Locator that will resolve to the location of the content on the reporting company’s website.
- 4) **Video Title [M]** – the title that the user has assigned to the uploaded content.
- 5) **Category [M]** – the video category or genre selected and assigned by the user to the uploaded content. Possible values are: Auto & Vehicles, Comedy, Entertainment, Film & Animation, Gadgets & Games, Howto & DIY, Music, News & Politics, People & Blogs, Pets & Animals, Sports, Travel & Places.
- 6) **Keywords [M]** – Keywords or tags assigned by the user to the uploaded content to facilitate searching.
- 7) **Music Duration [M]** – The duration of the music used in the uploaded content. In some cases this will be less than the Total Video Duration (for example, where an interview with the band is included) [format = MMMMSS]. For example: 000137 not 137 (one minute, thirty seven seconds).
- 8) **Total Video Duration [M]** – The total duration of the uploaded content [Format= MMMMSS]. For example:005635 not 5635 (fifty six minutes, thirty five seconds).
- 9) **Upload Date [M]** – The date the content was uploaded to the Reporting Company’s website [Format=CCYYMMDD].

## Usage Details Data Fields

The **record type 20** contains details of the Usage of the Release according to territory, price, Usage Type. There must be one record for each Release, by Usage Type, by Territory, and Price.

The letters in brackets confirm whether or not the supply of the information is Mandatory **[M]**, Conditional **[C]** or Optional **[O]**. A Conditional field may be Mandatory depending on the other fields completed and the type of service.

The Usage Details record contains the following fields

- 1) **Record Type [M]** –Value of “20” which identifies the record as the Release Detail Record.
- 2) **Reporting Company Identifier [M]** – The Reporting Company’s unique identifier for an Audio Release, Audiovisual Production or User Uploaded Content.
- 3) **Territory Code [M]** – The ISO 3166-1 code (alpha-2 code) which identifies the territory of Usage.  
[http://en.wikipedia.org/wiki/ISO\\_3166-1\\_alpha-2](http://en.wikipedia.org/wiki/ISO_3166-1_alpha-2)
- 4) **Usage Type [M]** – A code which classifies how the Release used:
  - **PD** = Permanent Download
  - **LD** = Limited Download
  - **ST** = Stream
  - **PW** = Pure Webcast
  - **IW** = Interactive Webcast
  - **RT** = Ringtones
  - **RB** = Ringbacks
- 5) **Release Price [M]** – Price charged per use for the Release. This can be zero if the Service does not charge on a per use basis. [Format=9999.99] (Also see Additional Direct Revenue, page 7)
- 6) **Price Currency [M]** – The ISO Code which identifies the currency of the price amounts.  
<http://www.xe.com/iso4217.php>
- 7) **Premium Upgrade Indicator [M]** – Indicates where an additional amount has been paid for a release for a premium value release (for example, where the release is not protected by DRM, the audio compression quality is higher, etc). The values are: **Y** = Yes; **N** = No.  
**Note:** The minima royalty calculation will not apply where this indicator is set to **Y**.
- 8) **Number of Uses [M]** – The total number of Uses of the Release for the specific Usage Type within the territory. [Format = 999999999]



## File Trailer Fields

There will be one record per file. The purpose of this record is to mark the end of the file

The letters in brackets confirm whether or not the supply of the information is Mandatory **[M]**, Conditional **[C]** or Optional **[O]**. A Conditional field may be Mandatory depending on the other fields completed and the type of service.

The File Trailer record contains the following fields

- 1) **Record Type [M]** -Value of "99" which identifies the record as the File Trailer Record
- 2) **Number of Records [M]** - This will be the total number of records contained in the data file including Header and Trailer records.
- 3) **Number of Audio Releases [M]** -The total number of Releases contained in the data file. This will equate the total number of unique Reporting Company Release Identifiers
- 4) **Number of Tracks [M]** - This will be the total number of Tracks contained in the data file. This will equate to the total number of type '11' records.
- 5) **Number of Audiovisual Releases [M]** - This will be the total number of Productions contained in the data file. This will equate to the total number of type '15' records.
- 6) **Number of User Uploaded Content Videos [M]** - This will be the total number of User Uploaded Content Videos. This will equate to the total number of type '19' records.
- 7) **Number of Usage Detail records [M]** - This will be the total number of Usage Detail records (type '20') contained in the data file.

Check

<p>“Broadcast”</p>	<p>means an electronic transmission of visual images, sounds or other information which</p> <p>(a) is transmitted for simultaneous reception by members of the public and is capable of being lawfully received by them, or</p> <p>(b) is transmitted at a time determined solely by the person making the transmission for presentation to members of the public;</p> <p>and which is not excepted by subclause 1 and references to broadcasting shall be construed accordingly.</p> <p>1. Excepted from the definition of “Broadcast” is any internet transmission unless it is:</p> <p>(i) a transmission taking place simultaneously on the internet and by other means,</p> <p>(ii) a transmission of recorded moving images or sounds forming part of a programme service offered by the person responsible for making the transmission, being a service in which programmes are transmitted at scheduled times determined by that person.</p> <p>For the avoidance of doubt the terms “broadcast” or “broadcasting” when used in this agreement without a capital “B” shall have the meaning given to them by the Act.</p>
<p>“Permanent Download Service”</p>	<p>means a service (or the relevant part of a service) by which a Musical Work is made available to the public via a Network in the form of a download and where such download may be retained by the User on a permanent basis.</p>
<p>“Limited Download / On-Demand Streaming Service “ or “LD/ODS Service”</p>	<p>means a service (or the relevant part of a service) whereby a User may receive a Musical Work by streaming on-demand via a Network (where the time and place at which such Musical Work is received is selected by the User) and/or may download via a Network that Musical Work but where such download may not be retained by the User on a permanent basis. Any service falling primarily within the foregoing definition but which also includes elements which fall within the definition of Premium and Interactive Webcasting Service and/or Pure Webcasting Service shall be deemed in its entirety to be a LD/ODS Service.</p>
<p>“Premium and Interactive Webcasting Service”</p>	<p>means a service (or the relevant part of a service) by which Musical Works are made available to the public via a Network and:</p> <p>(a) no permanent or temporary copy of any Musical Work is retained by the User; and</p> <p>(b) such service is neither a Pure Webcasting Service, a Permanent</p>

	Download Service, a LD/ODS Service or a Simulcast Service.
"Pure Webcasting Service"	<p>means a service (or the relevant part of a service) by which Musical Works are Broadcast (as that term is defined in this Schedule 1) to Users via a Network. For the avoidance of doubt, to constitute a Pure Webcasting Service, there must be:</p> <ul style="list-style-type: none"> <li>(a) no interactive functionality, for example (without limitation), no use of controls that enable the User to pause, skip, move forward or backwards through the stream;</li> <li>(b) no personalisation of the service by the User or the ability for the User to offer preferences which then dictate the tracks that are provided to that User, for example (without limitation), no ability for the User to rate tracks so as to influence subsequent tracks that are played;</li> <li>(c) no advanced notification to the User of titles of specific tracks to be played or specific albums from which tracks will be played (other than the introduction of the next track in DJ led services);</li> </ul>
"Limited Subscription Service"	<p>means an LD/ODS Service whereby the User:</p> <ul style="list-style-type: none"> <li>(a) pays to the Licensee a regular fee in order to access such service; and</li> </ul> <p>gains access, only while such fee continues to be paid and controlled by appropriate DRM, to 20,000 different Musical Works or less.</p>
"PC Subscription Service"	<p>means an LD/ODS Service whereby the User:</p> <ul style="list-style-type: none"> <li>(a) pays to the Licensee a regular fee in order to access such service; and</li> <li>(b) gains access, only while such fee continues to be paid and controlled by appropriate DRM, to in excess of 20,000 different Musical Works; and</li> <li>(c) is able, only while such fee continues to be paid and controlled by appropriate DRM, to store and listen to Musical Works accessed through such service on a personal computer;</li> <li>(d) is unable to store and listen to Musical Works accessed through such service on a portable Data Storage Device (such as an mp3 or WMA player).</li> </ul>
"Portable Subscription Service"	<p>means an LD/ODS Service whereby the User:</p> <ul style="list-style-type: none"> <li>(a) pays to the Licensee a regular fee in order to access such service; and</li> <li>(b) gains access, only while such fee continues to be paid and controlled by appropriate DRM, to in excess of 20,000 different Musical Works;Id</li> <li>(c) is able, only while such fee continues to be paid and controlled by appropriate DRM, to store and listen to Musical Works accessed through such service on a personal computer and</li> <li>(d) is able, only while such fee continues to be paid and controlled by</li> </ul>

	appropriate DRM, to store and listen to Musical Works accessed through such service on a portable Data Storage Device (such as an mp3 or WMA player).
“Subscription Permanent Download Service”	means a Permanent Download Service whereby the User pays to the Licensee a regular periodic fee in order to obtain permanent downloads.
“Webcasting Subscription Service”	means a Pure Webcasting Service or Premium and Interactive Webcasting Service (but not a Special Webcasting Service) whereby the User pays to the Licensee a regular fee in order to access such service.
“Special Webcasting Service”	means a Pure Webcasting Service or Premium and Interactive Webcasting Service where more than 50% of the sound recordings of the Musical works made available to the public (i) are by a single artist or band or (ii) comprise a live performance by a single artist or band with related performances by other artists and/or bands.

**Table 1: Applicable IREJOL Service Definitions**  
**(The table above is for guidance only. Please refer to the terms and conditions of the scheme for full Service Definitions)**

## Character Separated Version Specification

The Report will be accepted in a character separated format. The order of Record Types and data fields must be consistent with the specification described in section 0.

The Pipe character (“|”) is recommended as the character to be used to separate the data fields as this character is unlikely to be contained within any data field values. An empty field must be provided in place of optional data which has not been supplied. For example:

If a Pipe separated record type contains Field 1, Field 2, Field 3 and Field 4 but only values for Fields 1, 3 and 4 have been provided, then the record should be as follows:

*Field 1 Value||Field 3 Value|Field 4 Value*

***Please note, in the example above Field 2 should remain in the report but be left blank.***

# Fixed File Format Specification

Record Type	Record Name	Min. Length	Max. Length	Comments
00	File Header	232	600	Page 15 (Mandatory)
10	Audio Release Details	244	600	Page 16 (Mandatory)
11	Audio Track Details	422	600	Page 17 (Mandatory)
15	Audiovisual Release Details	339	600	Page 18 (Mandatory)
16	Music Cue Details	401	600	Page 19 (Mandatory)
19	User Generated Content Details	588	600	Page 24 (Mandatory)
20	Usage Details	42	600	Page 20 (Mandatory)
99	File Trailer	50	600	Page 21 (Mandatory)

On-line Reporting Data						
File Header			Record ID: 00			
There will be one record per file; the purpose of this record is to mark the beginning of the file.						
Field No	Item Name	Start Pos.	Size Bytes	Data Type	Mand	Values and Formats
1	Record Type	1	2	N	Y	Value = 00
2	Format	3	4	A	Y	Value = JOLS
3	Version	7	3	A	Y	Value = 2.0
4	Extract Date	10	8	N	Y	Format = CCYMMDD
5	Reporting Company Name	18	50	A	Y	
6	Trading Name	68	50	A	N	
7	Supplier Number	118	20	A	N	
8	Purchase Order Number	138	20	A	N	
9	Reporting Period Start Date	158	8	N	Y	Format = CCYMMDD
10	Reporting Period End Date	166	8	N	Y	Format = CCYMMDD
11	Service Type	174	10	A	Y	See Section 0 for list of valid codes.
12	Total Direct Revenue	184	12	N	C	Format = 999999999.99
13	Indirect Revenue Advertising	196	12	N	Y	Format = 999999999.99
14	Indirect Revenue Other	208	12	N	Y	Format = 999999999.99
15	Revenue Currency	220	3	A	Y	ISO 4217 (alpha-3) Currency Code
16	Total Number of Subscriptions	223	9	N	C	
17	Mobile Service Flag	232	1	A	Y	
18	Unused	233	368	A	N	Spaces
	Maximum Length	600				
	Minimum Length		232			

On-line Reporting Data						
Audio Release Details			Record ID: 10			
Column	Item Name	Start Pos.	Size Bytes	Data Type	Mand	Comments, Values and Formats
1	Record Type	1	2	N	Y	Value = 10
2	Reporting Company Identifier	3	16	A	Y	The Reporting Company's unique identifier for the Release.
3	Multi-Track Release Indicator	19	1	A	Y	"M"=Multi-Track Release "S"=Single Track Release
4	Customised Release Indicator	20	1	A	C	Mandatory where the Multi-Track Release Indicator = "M" "Y" = Yes "N" = No
5	Release Title	21	100	A	Y	
6	Featured Artist	121	80	A	Y	
7	Release/Record Catalogue Number	201	30	A	N	
8	<i>Original Issue Date of Release</i>	231	8	N	N	Format = CCYYMMDD
9	<i>Total Release Duration</i>	239	6	N	N	Format = MMMMSS
10	Unused	245	355	A	N	
	Maximum Length	600				
	Minimum Length		244			



On-line Reporting Data						
Audio Track Details			Record ID: 11			
Column	Item Name	Start Pos.	Size Bytes	Data Type	Mand	Comments, Values and Formats
1	Record Type	1	2	N	Y	Value = 11
2	Reporting Company Identifier	3	16	A	Y	The Reporting Company's unique identifier for the Release.
3	Reporting Company Track Identifier	19	16	A	N	
4	Work Identifier	35	16	A	N	Tunecode or ISWC
5	Recording ISRC	51	16	N	N	
6	Track Title	67	100	A	Y	
7	Featured Artist	167	80	A	Y	
8	Writer	247	80	A	C	
9	Publisher	327	80	A	N	
10	<i>Music Duration</i>	407	6	N	Y	Format = MMMSS
11	<i>Original Recording Issue Date</i>	413	8	N	N	Format = CCYYMMDD
12	<i>Audiovisual Indicator</i>	421	1	A	N	Set to "Y" if track is Audiovisual
13	<i>Non-Music Flag</i>	422	1	A	N	Set to "Y" if item is non-music
14	Unused	423	177	A	N	
	Maximum Length	600				
	Minimum Length		422			

On-line Reporting Data						
Audiovisual Release Details			Record ID:		15	
Column	Item Name	Start Pos.	Size Bytes	Data Type	Mand	Comments, Values and Formats
1	Record Type	1	2	N	Y	Value = 15
2	Reporting Company Production Identifier	3	20	A	Y	The Reporting Company's unique identifier for the Production
3	Society Production Identifier	23	20	A	N	The receiving Society's unique identifier for the Production
4	ISAN	43	30	A	N	
5	Production Name	73	100	A	Y	
6	Series Indicator	173	1	A	Y	"Y" = Yes "N" = No
7	Episode Number	174	10	N	C	Mandatory where the Series Indicator = "Y"
8	Episode Name	184	100	A	C	Mandatory where the Series Indicator = "Y"
9	Production Indicator	284	1	A	M	"P" = Promo/Trailer "N" = Programme "F" = Feature Film "C" = Commercial
10	Year of Production	285	4	N	C	Format = CCYY
11	Music Content Indicator	289	1	A	Y	"Y" = Contains music "N" = Contains no music "W" = Waiting for cue sheet "S" = Cue sheet previously supplied
12	Production Company Name	290	50	A	N	
13	Unused	340	261	A	N	
	Maximum Length	600				
	Minimum Length		339			

On-line Reporting Data						
Music Cue Details			Record ID: 16			
Column	Item Name	Start Pos.	Size Bytes	Data Type	Mand	Comments, Values and Formats
1	Record Type	1	2	N	Y	Value = 16
2	Reporting Company Identifier	3	20	A	Y	The Reporting Company's unique identifier for the Production
3	Work Identifier	23	16	A	N	
4	Recording ISRC	39	16	N	N	
5	Music Cue Title	55	100	A	Y	
6	Featured Artist	155	80	A	Y	
7	Writer	235	80	A	C	
8	Publisher	315	80	A	N	
9	<i>Music Duration</i>	395	6	N	Y	Format = MMMSS
10	<i>Library Work Indicator</i>	401	1	A	Y	"Y" = Yes "N" = No
11	Unused	402	198	A	N	
	Maximum Length	600				
	Minimum Length		401			

On-line Reporting Data						
User Uploaded Content Details			Record ID: 19			
Column	Item Name	Start Pos.	Size Bytes	Data Type	Mand	Comments, Values and Formats
1	Record Type	1	2	N	Y	Value = 19
2	Reporting Company Identifier	3	16	A	Y	The Reporting Company's unique identifier for the Release.
3	URL	19	200	A	Y	The URL for locating the content
4	Video Title	219	150	A	Y	The title that the user has assigned to the uploaded content
5	Category	369	200	A	Y	Keywords or tags assigned by the user to the uploaded content to facilitate searching
6	<i>Music Duration</i>	569	6	N	Y	Format = MMMMSS
7	<i>Total Video Duration</i>	575	6	N	Y	Format = MMMMSS
7	<i>Upload Date</i>	581	8	N	Y	Format = CCYYMMDD
8	Unused	589	11	A	N	
	Maximum Length	600				
	Minimum Length		588			

On-line Reporting Data						
Usage Details			Record ID: 20			
Column	Item Name	Start Pos.	Size Bytes	Data Type	Mand	Comments, Values and Formats
1	Record Type	1	2	N	Y	Value = 20
2	Reporting Company Identifier	3	16	A	Y	The Reporting Company's unique identifier for the Release or Production.
3	Territory Code	19	2	A	Y	ISO 3166-1 (alpha-2) Territory Code
4	Usage Type	21	2	N	Y	See Section 0 for list of valid codes.
5	Release Price	23	8	N	Y	Price charged per use for the Release. This can be zero if the service users are not charged directly per use. Format = 99999.99
6	Price Currency	31	3	A	Y	ISO 4217 (alpha-3) Currency Code
7	Premium Upgrade Indicator	34	1	A	Y	Value = Y or N
8	Number of Uses	35	9	N	Y	The number of Uses of the Release for the specific Usage Type
9	Unused	44	556	A	N	spaces
	Maximum Length	600				
	Minimum Length		42			

On-line Reporting Data						
File Trailer			Record ID: 99			
Column	Item Name	Start Pos	Size Bytes	Data Type	Mand	Comments, Values and Formats
1	Record Type	1	2	N	Y	Value = 99
2	Number of Records	3	8	N	Y	
3	Number of Releases	11	8	N	Y	
4	Number of Tracks	19	8	N	Y	
5	Number of Audiovisual Releases	27	8	N	Y	
6	Number of User Uploaded Content	35	8	N	Y	
7	Number of Usage Detail records	43	8	N	Y	
8	Unused	51	550	A	N	spaces
	Maximum Length	600				
	Minimum Length		50			

## SCHEDULE 5

### Form of Accounting Statement

Company name:

Contact name:

Monthly or Quarterly Reporting:

Month/Quarter ending:

Name of Licensed Service:

#### **Permanent Download Service**

##### **Details for the Month/Quarter**

Total Applicable Revenue for the Month/Quarter: €

(Gross Revenue exclusive of VAT, see clause 6 & 7 of Appendix 1)

Total Applicable Downloads for the Month/Quarter

Single Downloads:

Bundles:

8-12 Musical Works

13-17 Musical Works

18-29 Musical Works

30+ Musical Works

#### **Limited Download/On Demand Streaming Service**

##### **Details for the Month/Quarter**

Total Applicable Revenue for the Month/Quarter: €

(Gross Revenue exclusive of VAT, see clause 6 & 7 of Appendix 1)

Total Subscribers in Month/Quarter:

- Portable Subscription Service:

- PC Subscription Service

- Limited Subscription Service

Total Applicable Downloads for the Month/Quarter:

Singles Downloaded:

Bundles Downloaded:

8-12 Musical Works

13-17 Musical Works  
18-29 Musical Works  
30+ Musical Works

Total Applicable Musical Works played for the Month/Quarter:

**Special Webcasting Service**

**Details for the Month/Quarter**

Total Applicable Revenue for the Month/Quarter: €

(Gross Revenue exclusive of VAT, see clause 6 & 7 of Appendix 1)

Total Applicable Number of Musical works made available  
to the public per User :

Subscription/Non Subscription Service:

**Premium & Interactive Webcasting Service**

**Details for the Month/Quarter**

Total Applicable Revenue for the Month/Quarter: €

(Gross Revenue exclusive of VAT, see clause 6 & 7 of Appendix 1)

If a Webcasting Subscription Service  
the no. of Subscribers in Month/Quarter:

Total Applicable Number of Musical works made available  
to the public per User :

**Pure Webcasting Service**

**Details for the Month/Quarter**

Total Applicable Revenue for the Month/Quarter: €

(Gross Revenue exclusive of VAT, see clause 6 & 7 of Appendix 1)

If a Webcasting Subscription Service  
the no. of Subscribers in Month/Quarter:



Total Applicable Number of Musical works made available  
to the public per User :

**Date supplied:**

Please e-mail completed forms, within 14 days after the end of each calendar quarter,  
to: [onlinelicensing@imro.ie](mailto:onlinelicensing@imro.ie)

**SCHEDULE 6**

**Licence Details**

<b>Licensee</b>	
<b>Licensee Registered Address</b>	
<b>Agreement Number</b>	
<b>Licensed Services</b>	
<b>Additions to Definitions of "Territory"</b>	
<b>Quarterly Advance (if applicable)</b>	
<b>Commencement Date</b>	

**MCPSI AND IMRO  
JOINT LIMITED ONLINE EXPLOITATION LICENCE FOR PRIVATE USE  
2024**

**TERMS AND CONDITIONS**

**1. Definitions**

“**the Act**” means the Copyright and Related Rights Act 2000, as amended from time to time.

“**Agreement**” means these terms and conditions, the schedules to these terms and conditions and the AFL completed and signed by the Licensee and signed by the Licensors.

“**Application for Licence**” or “**AFL**” means the MCPSI-IMRO Limited Online Exploitation Licence application form.

“**Audio-Visual Material**” means any specific presentation of Musical Works in conjunction with images, whether moving or still. For the avoidance of doubt (but without prejudice to the express restrictions contained in this Agreement), the following shall not be treated as Audio-Visual Material for the purpose of this Agreement:

- (a) the fact that ordinary web pages (or equivalent) are visible to the User while the User is listening to music; or
- (b) the fact that the media player used to play the music generates random visual images while the music is playing;

provided, in both cases, that the User would not reasonably be expected to associate the Repertoire Works being played with the images presented or think that there is any deliberate association by the Licensee of the Repertoire Works with such images.

“**Broadcast**” means an electronic transmission of visual images, sounds or other information which

- (a) is transmitted for simultaneous reception by members of the public and is capable of being lawfully received by them, or
- (b) is transmitted at a time determined solely by the person making the transmission for presentation to members of the public;

and which is not excepted by subclause 1 below. and references to Broadcasting shall be construed accordingly.

1. Excepted from the definition of “Broadcast” is any internet transmission unless it is:

- (i) a transmission taking place simultaneously on the internet and by other means;
- (ii) a transmission of recorded moving images or sounds forming part of a programme service offered by the person responsible for making the transmission, being a service in which

programmes are transmitted at scheduled times determined by that person

For the avoidance of doubt the term “broadcast” or “broadcasting” when used in this Agreement without a capital “B” shall have the meaning given to it by the Act.

“**Clip**” means an audio-only or audio-visual sound recording of a Musical Work which a User may receive by streaming on-demand via a Network (where the time and place at which such Musical Work is received is selected by the User), provided that the duration of any Clip shall be no longer than the limits set out as follows:

Duration of complete sound recording of Musical Work	Maximum permitted duration of Clip
5 minutes or less	30 seconds
More than 5 but less than 10 minutes	45 seconds
10 minutes or more	60 seconds

“**Commencement Date**” means the Launch Date of the service as stated on the AFL, or 1<sup>st</sup> January 2008 if the Launch Date is prior to 1<sup>st</sup> January 2008.

“**Commercial Work**” means any Repertoire Work other than:

- (a) one where the Member owning or controlling the copyright in such Repertoire Work has authorised MCPS to license it as so-called production or library music; or
- (b) a Commissioned Work, PROVIDED THAT for the purposes of clauses 3.2 and 4.3, a Commissioned Work shall not be excluded from such definition where the commissioning agreement does not authorise the Licensee to use the Commissioned Work in the context set out in those clauses.

“**Commissioned Work**” means a Musical Work specially and expressly commissioned by the Licensee from composer/writer members of IMRO and/or MCPS.

“**Data Storage Device**” means any medium on which data can be stored (whether temporarily or permanently) whether existing now or invented in the future.

“**Download**” means the making available to the public of any one Musical Work, whereby such Musical Work may be retained by the User on a permanent basis. For the avoidance of doubt, the making available to the public for retention by the User on a permanent basis of ten (10) Musical Works shall be treated as ten (10) separate Downloads for the purposes of clause 5.1.

**“Excluded Service”** means any service (or the relevant part of a service) which falls within the scope (from time to time) of any of the following MCPSI/IMRO licensing schemes:

- (a) IMRO – Ringtone/Ringback Licensing Scheme
- (b) MCPSI – Ringtone Licensing Scheme
- (d) MCPSI – Ringback Licensing Scheme
- (d) MCPSI – Karaoke and MIDI Scheme
- (e) MCPSI – Music-on-hold Scheme
- (f) MCPSI – Supply of Background Music Services Scheme
- (g) MCPSI – Premium Telephone Line Services Scheme
- (h) IMRO – Online Licensing Scheme excluding Music Services and Ringtones.
- (i) IMRO/MCPSI Licensing Scheme for the Provision of Online and Mobile Music Services to the Public for Private Use
- (j) Joint IMRO/MCPSI Ringtone Licence Agreement
- (k) IMRO/MCPSI General Entertainment On Demand Licensing Scheme

**“Gross Revenue”** means:

- (a) all revenue received (or receivable) by the Licensee from Users in relation to the provision of the Licensed Services; and
- (b) all revenue received (or receivable) by the Licensee as a result of the placement of advertising on or within the Licensed Services; and
- (c) all revenue received (or receivable) by the Licensee as sponsorship fees in relation to the provision of the Licensed Services; and
- (d) all revenue received (or receivable) in the form of commissions from third parties as a result of Users accessing and/or purchasing from a service of a third party via the Licensed Services; and
- (e) any other revenue received (or receivable) by the Licensee arising in relation to the provision to Users of the Licensed Services (including, without limitation, such revenue received in relation to donations, barter or contra deals, such deals to be valued for these purposes);

and in each of the above cases such revenue shall, for the avoidance of doubt, include any such revenue whether received or receivable by the Licensee or any associate, affiliate, agent or representative of such party.

There shall be no other deduction or set-off from the above revenues other than refunds to Users for services that they were unable to use due to technical faults in the Licensed Services.

**“IMRO”** means Irish Music Rights Organisation CLG having its registered office at Copyright House, Pembroke Row, Lower Baggot Street, Dublin 2, Republic of Ireland contracting for and on behalf of itself and for and on behalf of and as agents of its various affiliated societies.

**“Joint Online Licence”** means a licence agreement under the “Licensing Scheme for the provision of Online and Mobile Music Services to the Public for Private Use” as published by the Licensors from time to time.

**“Licensed Service(s)”** means the service(s) set out in the AFL.

**“Licensee”** means the party that submits an AFL and is granted a licence by the Licensors subject to this Agreement.

**“Licensors”** means IMRO and MCPSI.

**“Limited Download / On Demand Streaming Service (LD/ODS)”** means a service (or the relevant part of a service), other than an Excluded Service, whereby a User may receive a Musical Work by streaming on-demand via a Network (where the time and place at which such Musical Work is received is selected by the User) and/or may download via a Network that Musical Work but where such download may not be retained by the User on a permanent basis. Any service falling primarily within the foregoing definition but which also includes elements which fall within the definition of Premium and Interactive Webcasting Service and/or Pure Webcasting Service shall be deemed in its entirety to be a LD/ODS Service.

**“MCPSI”** means mechanical Copyright Protection Society (Ireland) Limited whose registered office is at Copyright House, Pembroke Row, Lower Baggot Street, Dublin 2, Republic of Ireland contracting for and on behalf of and as agents of MCPS its various Members and affiliated societies.

**“MCPS”** means Mechanical-Copyright Protection Society Limited whose registered office is at 29-33 Berners Street London W1T 3AB.

**“Member”** means:

- (a) in the case of MCPS, each person, firm or company who or which, from time to time, has appointed MCPS as agent in relation to online exploitation either before or during the Term, PROVIDED THAT a member who has so appointed MCPS after the commencement of the Term shall only be regarded as a member for the purposes of this Agreement with effect from the date on which the Member so appointed MCPS; and
- (b) in the case of IMRO, any person, firm or company who or which, from time to time, pursuant to the Articles of Association of IMRO has been admitted either before or during the Term as a member of IMRO, PROVIDED THAT a member who has been so admitted after the commencement of the Term shall only be regarded as a member for the purposes of this Agreement with effect from the date of admission into IMRO.

**“Music Podcasting Service”** means a service (or the relevant part of a service) whereby Podcasts (as opposed to individual Musical Works) containing music may be made available via a Network to Users such that Users may retain a copy of such Podcast on their Data Storage Devices (whether permanently or temporarily).

**“Musical Work”** means any musical work (as defined in the Act) and any lyrics or words written to be used with such musical work (if applicable). It includes any part of such a work.

**“Music Service Provider”** means, the party which, in relation to a Music Service, most closely meets the following criteria:

- (a) contracts with the User in relation to the provision of the Licensed Service;
- (b) sets and controls the price the User pays;
- (c) can fully report on all elements of Gross Revenue (including relevant advertising revenues);
- (d) can fully report on all elements of music usage (or can procure such reporting);
- (e) controls how content is offered and bundled within the Licensed Service; and
- (f) carries out or authorises, on their instruction, the carrying out of the copyright restricted acts licensed under this Agreement.
- (g) any combination of (a) to (f) above.

**“Music Usage Declaration”** means the information referred to in clause 6.1, to be provided in the form set out at Schedule 1.

**“Music Service”** means a service or the relevant part of a service which is:

- (a) a Permanent Download Service;
- (b) a LD/ODS Service;
- (c) a Premium and Interactive Webcasting Service;
- (d) a Pure Webcasting Service;
- (e) A Music Podcasting Service;
- (f) A Clips Service: or
- (g) any combination of (a) to (f) above;

subject always to the limits as set out in clause 5.1.

**“Network”** means the internet, a mobile network or any other wired or wireless network.

**“Permanent Download Service”** means a service (or the relevant part of a service), other than an Excluded Service, by which a Musical Work is made available to the public via a Network in the form of a Download and where such Download may be retained by the User on a

permanent basis, and the term “Permanent Download” shall be construed accordingly.

**“Podcast”** means a downloadable, audio only programme that contains both music and speech where the podcast cannot be disaggregated into its individual tracks.

**“Podcasting Agreement”** shall mean a licence agreement under the Licensors’ “Licensing Scheme for the Provision of Online and Mobile Music Podcasting Services to the Public for Private Use”

**“Premium and Interactive Webcasting Service”** means a service (or the relevant part of a service), other than an Excluded Service, by which Musical Works are made available to the public via a Network and:

- (a) no permanent or temporary copy of any Musical Work is retained by the User; and
- (b) such service is neither a Pure Webcasting Service, a Permanent Download Service, a LD/ODS Service or a Simulcast Service.

**“Pure Webcasting Service”** means a service (or the relevant part of a service), other than an Excluded Service or a Simulcast Service, by which Musical Works are Broadcast (as that term is defined in this Agreement) to Users via a Network. For the avoidance of doubt, to constitute a Pure Webcasting Service, there must be:

- (a) no interactive functionality, for example (without limitation), no use of controls that enable the User to pause, skip, move forward or backwards through the stream;
- (b) no personalisation of the service by the User or the ability for the User to offer preferences which then dictate the tracks that are provided to that User, for example (without limitation), no ability for the User to rate tracks so as to influence subsequent tracks that are played;
- (c) no advanced notification to the User of titles of specific tracks to be played or specific albums from which tracks will be played (other than the introduction of the next track in DJ led services);
- (d) in any 3 hour period:
  - (i) no more than 3 songs from a particular album (including no more than 2 consecutively);
  - (ii) no more than 4 songs from a particular artist or from any compilation of tracks (including no more than 3 consecutively);
- (e) no archived programmes less than 5 hours in duration or available for more than 2 weeks;
- (f) no continuous programmes of less than 3 hours duration;
- (g) effective technologies, insofar as such technologies are commercially available and can be implemented without imposing unreasonable costs, which aim to prevent:

(i) a User or any other person or entity from automatically scanning the Licensee's transmissions alone or together with transmissions by other transmitting entities in order to select a particular sound recording to be transmitted to the User; and

(ii) a User from making copies, other than transient copies, of the sound recordings; and

(h) no automatic or intentional cause by the Licensee of the device receiving a transmission to switch from one program channel to another.

**"Quarter"** means each of the periods from 1st January to 31st March, 1st April to 30th June, 1st July to 30th September, and 1st October to 31st December, throughout the Term.

**"Repertoire Work"** means each Musical Work the relevant copyright in which is owned or controlled, from time to time, in the territory by:

(a) MCPSI or a member of MCPS or a Member or an associated society or an associated society member PROVIDED THAT (i) if one or more of those who own or control the copyright in a relevant Repertoire Work is not MCPSI or a Member of MCPS or an associated society or associated society member, the expression "Repertoire Work" shall only apply to such interest in the Repertoire Work as is owned or controlled by MCPSI or the associated society or the relevant Member or associated society member, and (ii) it shall exclude any Musical Works that a Member of MCPS or an associated society has withdrawn or withheld from this Agreement; and

(b) IMRO or a Member or an associated society or an associated society member PROVIDED THAT if one or more of those who own or control the copyright in a relevant Repertoire Work is not IMRO or a Member or an associated society or associated society member, the expression "Repertoire Work" shall only apply to such interest in the Repertoire Work as is owned or controlled by IMRO or the associated society or the relevant member or associated society member.

For the avoidance of doubt, if a Musical Work is a Repertoire Work in relation to one Licensor and not the other then it remains a Repertoire Work under this Agreement in relation only to the licence granted by that Licensor.

**"Royalty Fees"** means the royalties payable as set out in clause 5.

**"Server Territory"** means the European Economic Area, Switzerland, the United States of America, Canada and such other territories as may be agreed in writing by the parties.

**"Simulcast Service"** means the Broadcast (as that term is defined in this agreement) of a programme via a Network where such Broadcast:

(a) is simultaneous with the Broadcast of such programme via a traditional terrestrial, satellite or cable television or radio service; and

(b) is made from the website or other service of the originating Broadcaster.

**"Stream"** means the making available to the public of any Musical Work. For the avoidance of doubt, the making available to the public of for example, ten (10) Musical Works shall be treated as ten (10) separate Streams for the purposes of clause 5.1

**"Term"** means the period starting on the Commencement Date and ending upon the date set out in clause 10.1 (unless terminated earlier under clauses 10.2 or 10.3).

**"Territory"** means Ireland and such other countries as the Licensors and the Licensee may agree in writing.

**"User"** means a natural person in the Territory who receives the Licensed Services for their own private and non-commercial use.

**"VAT"** means value added tax and each like tax imposed in addition to or in substitution there for.

## 2. Grant of Licence

2.1 Subject to and conditional upon compliance with the terms and conditions contained herein and in particular subject to the exclusions and restrictions set out in clauses 3 and 4, MCPSI grants the Licensee a non-exclusive licence to do the following during the Term:

(a) to reproduce Repertoire Works on servers within the Server Territory for the purpose of transmitting the same to Users (for the User's own private and non-commercial use) by means of the Licensed Services; and

(b) where the Licensed Services expressly authorise the temporary or permanent reproduction of Repertoire Works on Users' Data Storage Devices, to cause such copies to be made in the Territory for the User's own private and non-commercial use.

2.2 Subject to and conditional upon compliance with the terms and conditions contained herein and in particular subject to the exclusions and restrictions set out in clauses 3 and 4, IMRO grants the Licensee a non-exclusive licence, during the Term, to make available to the public (as that term is defined in section 40 (1) (a) (but not for the avoidance of doubt Section 40 (1) (b) – (g) inclusive of the Act) and to authorise the making available to the public of Repertoire Works within the Territory solely as part of and for the purposes of the provision of the Licensed Services.

2.3 The above licences shall apply where Repertoire Works are used in audio-only material and, subject to clause 3.2, Audio Visual Material.

### 3. Exceptions and Limitations

3.1 The licences granted under clause 2 of this Agreement are valid only insofar as:

- (a) the Licensed Services are Music Services; and
- (b) the Licensee is the Music Service Provider in relation to the Licensed Services.
- (c) the Gross Revenue from the Licensed Services does not exceed €7,000 (excluding VAT) per annum. The Licensee shall notify the Licensors if the Gross Revenue from the Licensed Services exceeds the sum of €7,000 (excluding VAT) per annum. In such a case, the Licensee shall apply for a Joint Online Licence, which if granted, shall replace this Agreement.

3.2 The incorporation of Commercial Works into Audio-Visual Material is only licensed under this Agreement where the Audio-Visual Material consists of:

- (a) a music videogram; or
- (b) a live concert performance or a film of a live concert performance by the artist performing that particular Commercial Work; or
- (c) subject to clause 4.3, such Commercial Works being combined with photographs or other images relating to the artist performing the Commercial Work or the composer of the Commercial Work; or
- (d) subject to clause 4.3, an interview with an artist, composer, producer or other person involved in the creation, performance or production of music where the Commercial Work(s) used are associated with the interviewee(s).

For the avoidance of doubt, such Audio-Visual Material as is licensed under 3.2(a) to (d) above is only licensed insofar as it is reproduced or made available to the public via the Licensed Services.

3.3 For the avoidance of doubt, this Agreement does not grant any "synchronisation licence" (to the extent that such a licence may be required by the Licensee) covering the initial fixation of Repertoire Works in combination with visual images to create and produce Audio-Visual Material.

3.4 For the avoidance of doubt, the licences granted under clause 2 of this Agreement shall not authorise the manufacture or distribution of physical products containing Repertoire Works, such as (without limitation) the ordering of compact discs (or any other type of physical media) via a Music Service, but which are distributed by mail.

3.5 For the avoidance of doubt, the licences granted under clause 2 of this Agreement shall not extend to the performing, showing or playing a copy in public, broadcasting a copy, including a copy in a cable programme service, issuing copies of or renting or lending (as those terms is used in the Act) of Repertoire Works, whether as part of the Licensed Services or otherwise.

3.6 The licence granted under clause 2.1 of this Agreement shall not permit the use of Repertoire Work(s) with any advertising or sponsorship where:

- (a) such Repertoire Work(s) are incorporated into such advertising or sponsorship; or
- (b) such Repertoire Work(s) are otherwise presented in such a way that a reasonable person might associate the Repertoire Work(s) with the advertising or sponsorship.

3.7 For the avoidance of doubt (and without prejudice to the generality of clause 3.6), the licences granted under these terms and conditions shall not apply to any Repertoire Work(s) made available for the purpose of (whether in whole or in part):

- (a) directly or indirectly encouraging the User to purchase or obtain goods or services of whatsoever nature (other than music via the Licensed Service); or
- (b) promoting the branding of the Licensee, any affiliate of the Licensee or any third party; in such a manner that:
  - (i) one or more particular Repertoire Works, composers or writers are associated with such promotion; or
  - (ii) a reasonable person might assume that there was an association between particular Repertoire Works, composers or writers and such promotion;

3.8 The licence granted under clause 2.1 shall not apply to graphic copies (meaning, without limitation, copies of lyrics, notation or scores) of Repertoire Works. For the avoidance of doubt, the licences granted under these terms and conditions shall not apply to any "karaoke" service within a Music Service.

3.9 The licence granted under clause 2.2 shall only apply to a Repertoire Work made available to the public as part of a Licensed Service where the Licensee has the benefit of a valid licence for or a right to make a reproduction of that particular Repertoire Work and for that particular form of exploitation via the Licensed Service either pursuant to these terms and conditions or otherwise. By way of example only, the licence granted by MCPSI under clause 2.1 does not cover the copying of Repertoire Works in an advertisement (see clause 3.5 above). However, clause 3.6 does not apply to the licence granted

by IMRO under clause 2.2. Therefore, pursuant to this clause 3.9, the licence granted by IMRO under clause 2.2 would not apply (in the context of this example) unless the Licensee has the benefit of a right to copy the Repertoire Work for use in that advertisement (and on the Licensed Service(s)).

3.10 The licences granted under clause 2 of this Agreement shall not apply to any Repertoire Works reproduced or made available to the public within a Podcast unless:

(a) each programme comprising each Podcast contains both speech and music with the speech interspersed throughout the programme;

(b) such Podcast is provided only in the form of a programme in its entirety and not in the form of individual tracks or portions of such a programme;

(c) there can be no guide providing details of the time at which particular tracks appear; and

(d) no flags or other markers are inserted within such Podcast which may directly indicate or which may be used to indirectly infer the start and end point of tracks or segments of tracks.

3.11 The licences granted under clause 2 of this Agreement shall not apply to any Repertoire Works reproduced or made available to the public within a Podcast if:

(a) there is any Audio-Visual Material incorporated into the Podcast (unless Licensors provides their prior written approval in relation to such Audio-Visual Material); or

(b) the Podcast includes more than 2 Repertoire Works from a particular album or more than 2 Repertoire Works performed by a particular artist or written by a particular composer without prior written approval of the Licensors;  
or

(c) more than 50% of the Repertoire Works included within such Podcast are written by the same composer or writing partnership or are performed by the same artist without prior written approval of the Licensors unless the relevant Member has expressly consented thereto.

3.12 For the avoidance of doubt, this Agreement grants no licence whatsoever in relation to Repertoire Works which are made available by the Licensee outside of the Licensed Service. However, such other exploitation of Repertoire Works may fall within the scope of other licensing schemes operated by the Licensors, details of which shall be made available to the Licensee on request.

#### Further Restrictions

4.1 The licences granted under this Agreement do not cover any Repertoire Works which are dramatico-

musical works unless otherwise agreed by the Licensors.

4.2 The licences granted under this Agreement shall not extend to or permit any adaptation of any Repertoire Work to be copied or made available to the public as part of a Licensed Service unless the relevant Member has consented to such adaptation. By way of example only, this applies to:

(a) any sampling (meaning the taking of part of the music and/or lyrics of a Repertoire Work and incorporating such part into another Musical Work) or the making available to the public or reproduction in the form of a sample of such part of a Repertoire Work; or

(b) using with music lyrics other than those written to be used with the music or authorised for use with the music; or

(c) using with lyrics music other than that written to be used with the lyrics or authorised for use with the lyrics.

However, subject always to clause 4.7 and provided that such alterations do not amount to an adaptation of a Repertoire Work and do not contravene clause 4.3 then this Agreement shall apply in relation to Repertoire Works that have been modified (including music and/or lyrics) for the purpose of satisfying the requirements of the relevant recording.

4.3 The licences granted under this Agreement shall not extend to:

(a) the reproduction or making available to the public of any Commercial Work or part thereof in the form of a parody or burlesque of any Commercial Work or of any composer or writer of any Commercial Work or any band or other group of artists which includes any composer or writer of any Commercial Work; or

(b) the use of any Commercial Work in any context which the Licensee ought reasonably to consider as being likely to be insulting or detrimental to the composer featured on the commercially released sound recording of the music or the relevant Member or associated society member.

4.4 All rights not specifically granted under this Agreement are hereby reserved.

4.5 This Agreement only covers Repertoire Works. It does not extend to other rights or interests, including (by way of example only), rights in sound recordings, films, dramatic works, performers' rights or rights in performances. The Licensee is required to obtain the appropriate waivers, consents and/or licences from the person(s) owning or controlling rights in relation to sound recordings containing Repertoire Works or performers of that Repertoire Work.



4.6 Any additional limitations in relation to the Associated Societies' rights to grant the licences set out in clause 2 of this Agreement which have been notified to the Licensors shall be notified to the Licensee in writing (which may include by email) and shall be binding no less than 10 days following such notice. Where any restriction of a material nature is added, the Licensee shall have the right to terminate this Agreement by giving written notice to the Licensors.

4.7 It is the responsibility of the Licensee to obtain all necessary licences in relation to any Musical Work which is not, or to the extent that it is not, a Repertoire Work, and no licence is granted under this Agreement in relation thereto.

4.8 Nothing in this Agreement affects the moral rights of authors of Repertoire Works whether subsisting in Ireland or any other territory.

## 5 Fees and Payment

5.1 In consideration of the licences and authorisations granted under this Agreement, the Licensee shall pay to the Licensors the following Royalty Fees:

Type of service	Digital Starter (per annum)	Band A (per annum)	Band B (per annum)	Band C (per annum)
<b>Limited Download/ On Demand Streaming Service</b>	<b>€91+ VAT</b> < 22,500 streams per annum	<b>€181 +VAT</b> < 45,000 streams per annum	<b>€361 +VAT</b> < 90,000 streams per annum	<b>€867 +VAT</b> < 225,000 streams per annum
<b>Pure Webcasting Service</b>	<b>€91 + VAT</b> < 82,500 streams per annum	<b>€181 + VAT</b> < 165,000 streams per annum	<b>€361 +VAT</b> < 330,000 streams per annum	<b>€867 +VAT</b> < 900,000 streams per annum
<b>Premium and Interactive Webcasting Service</b>	<b>€91 + VAT</b> < 57,500 streams per annum	<b>€181 +VAT</b> < 115,000 streams per annum	<b>€361 +VAT</b> < 230,000 streams per annum	<b>€832 +VAT</b> < 575,000 streams per annum
<b>Permanent Download Service</b>	<b>€91 + VAT</b> < 1,250 downloads per annum.	<b>€181 +VAT</b> < 2,500 downloads per annum	<b>€361 +VAT</b> < 5,000 downloads per annum	<b>€904 +VAT</b> < 12,500 downloads per annum
<b>Music Podcasting Service</b>	<b>€91 +VAT</b> < 34,000 downloaded works per annum	<b>€181 +VAT</b> < 68,000 downloaded works per annum	<b>€361 +VAT</b> <136,000 downloaded works per annum	<b>€904 +VAT</b> < 340,000 downloaded works per annum

Type of Service	Band AA	Band A	Band B	Band C
Clips Service	€91 +VAT 1-250 Clips  Made available at any one time	€181 +VAT 251-500 Clips  Made available at any one time	€344+VAT 501-1000 Clips  Made available at any one time	€904+VAT 1001-2500 Clips  Made available at any one time

- 5.2 The Royalty Fees set out in clause 5.1 above shall be cumulative and for any service which combines elements from the above table, an aggregate fee shall be payable. By way of example only, the Royalty Fees payable for a service which provides less than 45,000 On Demand Streams and up to 5,000 Permanent Downloads per annum shall be €515.
- 5.3 If the combined Royalty Fees in respect of the Licensed Services exceed €300, the Licensee may apply for a Joint Online Licence. If the Licensee's application is successful, the Joint Online Licence shall replace this Agreement.
- 5.4 The Licensee shall notify the Licensors immediately if the maximum usage limits set out in clause 5.1 above are exceeded. If these maximum usage limits are exceeded, this agreement shall terminate and the Licensee shall apply for a Joint Online Licence.
- 5.5 The Licensee shall notify the Licensors if The Gross Revenue from the Licensed Services (excluding Music Podcasting Services and Clips Services) exceeds the sum of €7,000 (excluding VAT) per annum. In such circumstances, this Agreement shall terminate and the Licensee shall apply for a Joint Online Licence, which if granted, shall replace this Agreement
- 5.6 The Licensee shall notify the Licensors if the Gross Revenue from the Music Podcasting Services exceeds the sum of €7,000 (excluding VAT) per annum. In such circumstances, the Agreement shall terminate and the Licensee shall apply for a Podcasting Agreement, which if granted, shall replace this Agreement.
- 5.7 The Licensee shall notify the Licensors immediately if the Licensee's usage of any of the Musical Services exceeds the amount stated in the bandings detailed at clause 5.1 above, so that the amount the Licensee pays as Royalty Fees under clause 5.1 may be adjusted in line with those bandings.
- 5.8 The Licensee shall notify the Licensors immediately if the Licensee is to launch a new service which constitutes a Music Service and therefore requires a licence from the Licensors. The Licensee shall submit to the Licensors a fully and accurately completed Application for Licence 28 days before the launch of any such new service.

- 5.8 The Licensee shall notify the Licensors promptly of any material change in the information provided in the Application for Licence and the effective date of such change.
- 5.9 The Licensors, on behalf of themselves, MCPS and each of the Members and the associated societies, shall raise an invoice for the due amount, and the Licensee shall pay such invoice in full by electronic bank transfer, or if agreed with the Licensee, by direct debit or by or cheque within 30 days of the invoice date.
- 5.10 All licence fees and payments referred to in this Agreement are subject to VAT or other equivalent sales tax. The Licensee shall pay to the Licensors VAT or other equivalent sales tax (if applicable) at the rate or rates from time to time in force on any sums payable under this Agreement.
- 5.11 Except as expressly set out in these terms and conditions, no deduction in respect of any tax, or any other deduction or set-off of whatsoever nature, shall be made in calculating or paying any sum due under this Agreement.
- 5.12 Without prejudice to any other right or remedy of the Licensors, and without imposing an obligation to accept late payment, where any fees payable under this Agreement are not paid by the due date (or the date on which such fees should ordinarily have been paid in circumstances where the Licensors have been unable to submit an invoice) due to default of the Licensee, the Licensee shall (if required by the Licensors) pay interest on such late payment calculated on a daily basis at an annual rate of 3% over the prime overdraft rate, current from time to time, of Bank of Ireland payable from the date on which the payment should have been made to the date on which the payment was made.
- 5.13 All payments made under this Agreement shall be in Euro unless otherwise agreed by the parties in writing. Where it is necessary to convert an amount payable to Euro from another currency, the exchange rate used shall be the Irish Times closing mid market rate on the first working day of the Quarter in which the payment is made. The Licensee shall pay all bank charges on transfers of sums payable by the Licensee to the Licensors.

## 6. Supply of Information

- 6.1 In relation to any and all Repertoire Works reproduced and made available to the public under this Agreement via all Licensed Services, the Licensee will deliver a fully and accurately completed Music Usage Declaration to the Licensors or to the Licensors' duly authorised agent (details of which will be provided to the Licensee) within 14 days of the end of each Quarter.
- 6.2 The Licensee must also supply the Licensors with any further information or documentation in its possession, power, custody or control (and use its reasonable endeavours to supply the Licensors

with any further information or documentation not in its possession, power, custody or control) reasonably requested by the Licensors at any time, in order to enable the Licensors to verify the Repertoire Work(s) which have been reproduced or made available to the public via all Licensed Services.

6.3 Where any or all of the Licensed Services are accessible by Users only on payment of subscription or other similar payment (or access is otherwise limited or controlled in some way), the Licensee shall, upon request of the Licensors, use reasonable endeavours to ensure that such Licensed Services are at all times accessible by the Licensors free of charge for the purposes of the Licensors verifying that the Licensee is acting in accordance with this Agreement. For the avoidance of doubt, the Licensee shall not be required to provide free access to Downloads under a Permanent Download Service or to provide free access to a mobile phone network or internet access.

6.4 The email addresses for delivery of the Music Usage Declaration referred to in clauses 6.1 are

onlinelicensing@imro.ie  
onlinelicensing@mcps.ie

6.5 Without prejudice to any right in law that the Licensors may have to obtain such information, the Licensee shall not be obliged to provide to the Licensors any information which identifies Users or which otherwise constitutes "personal data" as defined in the Data Protection Acts 1988 and 2003. For the avoidance of doubt, the Licensee must still provide all required Music Usage Information (or other information to be provided under this Agreement), but is entitled to remove any element of it which reveals the identity of Users or otherwise causes it to include or constitute "personal data".

## 7. Credits and Notices

7.1 The Licensee shall include on each of the Licensed Services:

- (a) the logos of IMRO and MCPSI; and
- (b) details of the following websites and, where practical, hypertext links to it:

www.imro.ie and

www.mcps.ie

Approval of the Licensors shall be deemed to be given to the positioning of the above credits and notices within the terms and conditions of the Licensed Service(s) where it is not reasonably practical to position such information elsewhere.

## 8. Auditing

8.1 The Licensee shall keep and make available for inspection upon reasonable notice (and shall procure that each relevant party keeps and makes available for inspection upon reasonable notice),

both during and for twelve months after termination of this Agreement, proper, detailed books and records relating to (a) use of all Musical Works and (b) any income or other consideration received by or on behalf of the Licensee in relation to or arising from the Licensed Services, together with any supporting documentation relating thereto covering the period up to six years prior to the date of notification of audit.

8.2 For the purposes of this clause 8, the Licensee shall allow upon reasonable notice (and shall procure that each relevant party shall allow) access to its premises to inspect relevant accounting records, but not more than once per annum. The duly authorised representatives (who shall be external qualified accountants or auditors unless otherwise agreed between the parties) of the Licensors shall have such access to the Licensee's premises and shall be entitled to inspect, make extracts and take copies of any of the information and/or documentation available and to carry out such work as is, in their reasonable opinion, considered necessary to verify compliance with this Agreement.

8.3 If tests under any audit and verification process indicate under-payment of the correct Royalty Fee during the period under audit, then, without prejudice to the Licensors' other rights under this Agreement, the Licensee shall pay the amount of the underpayment plus interest based on the period from which the correct fee should have been paid to the Licensors to the date when it was actually paid (at the rates set out in clause 5.11).

8.4 If any audit and verification process discloses (a) under-payment of more than 7.5% of the correct Royalty Fee during the period under audit and/or (b) failures to report correctly (so as to affect a distribution by the Licensors to their Members) amounting to at least 7.5% of the music usage during the period under audit, then, without prejudice to the Licensors' other rights under this Agreement, the Licensee shall pay, in addition to the payment referred to in clause 8.3, the Licensors' reasonable costs of such audit and verification within 28 days of receipt of the Licensors' VAT invoice therefor.

8.5 The Licensors shall not (and shall procure that their representatives shall not), without the Licensee's written consent, disclose to any third party any confidential information of the Licensee (so long as it remains confidential) received in the course of an audit carried out under this clause 8, save that such confidential information may be disclosed to the Licensors' directors, board sub-committee members officers, employees and professional advisors (solely where such persons are under a duty of confidentiality in relation to information so received and the Licensors shall be liable to the Licensee in respect of any breach of such confidentiality obligation) solely for purposes connected with this Agreement.

8.6 For the avoidance of doubt, books, records and accounting records as referred to in clauses 8.1

and 8.2 above shall include data, information and records held on computers.

## 9. Security and Encryption

Unless agreed otherwise, the Licensee will utilise or require the utilisation of an industry security standard which is developed and is available for use in the protection of Repertoire Works. Until such time, the Licensee must use its reasonable endeavours to prevent unauthorised copying and/or the unauthorised issuing of copies of Repertoire Works by whatever technical means are practicable. Upon request the Licensee will inform the Licensors concerning its progress in relation to fulfilling this obligation.

## 10. Termination and Expiry

- 10.1 This Agreement shall expire on 31 December 2024 unless terminated earlier by written agreement or in accordance with the terms of this clause 10.
- 10.2 This Agreement may be terminated by either party by the terminating party giving the other party not less than three calendar months notice in writing.
- 10.3 Each party shall have the right to terminate this Agreement by notice forthwith where the other party:
  - (a) commits a material breach of this Agreement which is capable of remedy and fails to remedy such breach within 14 clear days after receipt of notice of such breach; or
  - (b) commits a material breach of this Agreement which is not capable of remedy; or
  - (c) the other goes into receivership or any resolution is passed for its winding-up, examinership or liquidation (other than for the purposes of reconstruction or amalgamation) or is otherwise unable to pay its debts,

and, for the avoidance of doubt, any breach which consists of a failure by either party to perform an obligation under this Agreement within any period required or by any date specified under this Agreement shall be deemed to be capable of remedy if such obligation is performed by such party within the 14 day cure period specified in clause 10.3(a) above.

## 11. No Assignment

The licences granted under this Agreement are personal to the Licensee and the Licensee may not assign, sub-license or otherwise transfer any or all of its rights or obligations under this Agreement without the written agreement of both MCPSI and IMRO.

## 12. Miscellaneous

- 12.1 No delay or omission in exercising any right or remedy hereunder shall operate as a waiver thereof or of any other right or remedy and no single or partial exercise thereof shall preclude any other or further exercise thereof or the exercise of any other rights or remedies. No waiver shall be binding or effectual for any purpose unless expressed in writing and signed by the party giving it and any such waiver shall be effective only in the specific instance and for the purpose given.
- 12.2 This Agreement sets forth the entire agreement of the parties in relation to the subject matter hereof and each of the parties hereto acknowledges that it has not entered into this Agreement in reliance on any representation or term not contained in this Agreement. This Agreement shall not be modified or varied except by a written instrument signed by the parties hereto.
- 12.3 The headings to the clauses in this Agreement are included for ease of reference only and are not part of this Agreement and are not to be taken into account in its construction.
- 12.4 The parties shall (and shall procure that any other necessary party within its control shall) execute all such documents and do all such acts and things as may be reasonably be required on or subsequent to completion of this Agreement for securing each of the obligations of the respective parties under this Agreement.
- 12.5 If this Agreement creates any rights which would in the absence of this provision be enforceable by any person not a party to this Agreement, such rights shall not be enforceable.
- 12.6 This Agreement shall be construed according to the laws of Ireland and the parties agree to submit to the jurisdiction of the Irish Courts.

**JOINT MCPSI AND IMRO  
LIMITED ONLINE EXPLOITATION LICENCE 2024**

**SCHEDULE 1  
MUSIC USAGE DECLARATION FORM**

**To be completed within 14 days of the end of the Quarter**

<b>Licence Number</b>	
<b>Company Name</b>	
<b>Contact Name</b>	
<b>Contact Email Address</b>	
<b>Contact Address</b>	
<b>Telephone Number</b>	
<b>Name of the service</b>	
<b>Gross Revenue generated by the service in licence Term</b>	

<b>Music Usage Details (for the Quarter)</b>		
<b>Clips</b>	Number made available at any one time during the Term	
<b>Limited Download/On Demand Streaming Service</b>	Number of Limited Downloads/Streams delivered during the Term	
<b>Pure Webcasting Service</b>	Number of Streams delivered during the Term	
<b>Premium and Interactive Webcasting Service</b>	Number of Streams delivered during the Term	
<b>Permanent Download Service</b>	Number of Downloads delivered during the Term	
<b>Music Podcasting Service</b>	Average Number of Musical Works on Podcasts delivered during the Term	
	Number of Podcasts downloaded during the Term	
	Total number of Musical Works downloaded during the Term	

**JOINT MCPSI AND IMRO RINGTONE  
LICENCE AGREEMENT**

**RINGTONE LICENCE AGREEMENT**

NAMES OF LICENSORS	<p>MECHANICAL-COPYRIGHT PROTECTION SOCIETY IRELAND LIMITED whose registered office is at Copyright House, Pembroke Row, Lower Baggot Street, Dublin 2, Ireland (“MCPSI”) contracting for and on behalf of and as agent of MECHANICAL-COPYRIGHT PROTECTION SOCIETY LIMITED having its registered office at 2nd Floor, Synergy House, 114-118 Southampton Row, London, WC1B 5AA, England (“MCPS”) and its various Members and the Associated Societies (as defined below); and</p> <p>IRISH MUSIC RIGHTS ORGANISATION CLG whose registered office is at CopyrightHouse, Pembroke Row, Lower Baggot Street, Dublin 2, Ireland (“IMRO”) contracting for and on behalf of itself and for and on behalf of and as agents of its Associated Societies;</p> <p>together “<b>the Licensors</b>” and each a “<b>Licensor</b>”.</p>
NAME OF LICENSEE	<p>(“<b>the Licensee</b>”)</p>
REGISTERED ADDRESS OF LICENSEE	
COMPANY NUMBER OF LICENSEE (IF APPLICABLE)	
LICENSED SERVICES	
COMMENCEMENT OF AGREEMENT	<p>[ ] (“<b>the Commencement Date</b>”)</p>

The terms and conditions of this Agreement are attached

**Signed for and on behalf of MCPSI:**

\_\_\_\_\_ **Date:** \_\_\_\_\_

**Name:** \_\_\_\_\_

**Signed for and on behalf of IMRO:**

\_\_\_\_\_ **Date:** \_\_\_\_\_

**Name:** \_\_\_\_\_

**Signed for and on behalf of the Licensee:**

\_\_\_\_\_ **Date:** \_\_\_\_\_

**Name:** \_\_\_\_\_



## TERMS AND CONDITIONS

### 1. Definitions

“**Accounting Statement**” means the MCPSI-IMRO Ringtone revenue reporting form as set out in Schedule 2 to this Agreement.

“**Agreement**” means these terms and conditions and the schedules to these terms and conditions.

“**Applicable Revenue**” means the Gross Revenue less VAT (or other equivalent sales tax, where applicable).

“**Audio-Visual Material**” means any specific presentation of Musical Works in synchronisation or otherwise with images, whether moving or still.

For the avoidance of doubt (but without prejudice to the express restrictions contained in this Agreement), the following shall not be treated as Audio-Visual Material for the purpose of this Agreement:

- (a) the fact that ordinary web pages (or equivalent) are visible to the User while the User is listening to a preview or to a Ringtone; or
- (b) the fact that the Device used to pay the Ringtone generates random visual images while the Ringtone is playing;

provided in both cases, that the User would not reasonably be expected to associate the Repertoire Works being played with the images presented or think that there is any deliberate association by the Licensee of the Repertoire Works with such images.

“**Associated Society**” means each collecting society (or other body representing rights in Musical Works) with which MCPS and/or IMRO has, from time to time, an agreement under which MCPS and/or IMRO is authorised to grant licences in relation to the other society's (or body's) repertoire for the purpose of this Agreement PROVIDED THAT where such an agreement is only entered into after the commencement of the Term, a collecting society (or other body) shall only be regarded as an “Associated Society” for the purposes of this Agreement with effect from the date of signature of such agreement with MCPS and/or IMRO (as applicable).

“**Associated Society Member**” means any person, firm or company who or which has been notified, from time to time, as being a member of an Associated Society by the relevant Associated Society to MCPS and/or IMRO.

“**Act**” means the Copyright and Related Rights Act 2000 as amended from time to time.

“**Device**” means a portable or static electronic communications device which is capable of allowing Users to communicate with each other via wire and/or wireless networks and which is capable of playing a Ringtone.

“**Dramatico-Musical Work**” means any ballet, opera, operetta, musical, musical play or work of a similar nature.

“**Gross Revenue**” shall have the meaning set out in schedule 1.

“**Ireland**” means the territory over which the government of Ireland currently exercises jurisdiction.

“**IVR**” means an interactive voice response system: a software application that allows a telephone caller to interact with a computer through a combination of voice telephone input and touch-tone keypad selection and provides appropriate responses in the form of music, voice, fax, callback, e-mail or other media. Each response by the caller triggers another response from the computer until the caller has completed their transaction.

“**Making Available to the Public**” means any act referred to in Section 40(1)(a) of the Act

“**Musical Work**” means any musical work (as defined in the Act) and any lyrics or words written to be used with such musical work (if applicable). It includes any part of such a work.

“**Music Service Provider**” means the party which, in relation to a Ringtone, most closely meets the following criteria:

- (a) contracts with the purchaser of the Ringtone (including when provided for free) in relation to the provision of the Ringtone;
- (b) sets and controls the price the purchaser of the Ringtone pays;
- (c) can fully report on all elements of Relevant Revenue (including relevant advertising revenues);
- (d) can fully report on all elements of music usage (or can procure such reporting);
- (e) controls how Ringtone content is offered and bundled;
- (f) carries out or authorises, on their instruction, the carrying out of the copyright restricted acts licensed under this Agreement.

“**Music Usage Information**” means the information required in the reporting form as set out in Schedule 3 to this Agreement.

“**Music Videogram**” means any audio-visual production:

- (a) which has as the main feature of the soundtrack thereof a recording of a single Repertoire Work copies of which recording have been or are intended to be released in digital or physical form for sale to the general public; and
- (b) the making of which was carried out by or on behalf of the record company releasing that recording or by or on behalf of the main artist(s) featured in that recording.

“**Permitted Excerpts**” refers only to Dramatico-Musical Works and means excerpts where the use of all such excerpts in any Audio-Visual Material complies with all the following limitations:

- (a) the total duration of the excerpts does not exceed one minute
- (b) the use is not a “potted version” of the Dramatico-Musical Work;

- (c) the use is not or does not cover a complete act of the Dramatico-Musical Work;
- (d) each excerpt is not presented in a "dramatic form" as defined below; and
- (e) as regards ballets specifically devised for television or excerpts from existing ballets, the total duration does not exceed five minutes.

A dramatic form shall be deemed to be created only by a performance in which there is a distinct plot depicted by actors and where the story of the Dramatico-Musical Work and/or its associated words is woven into and carries forward the plot and its accompanying action (a dramatic form shall not, for example, be deemed to be created by the use of costume, scenery, and/or any dance routine merely to provide an acceptable presentation of the work). For the purposes of this paragraph the word "actors" shall include actors, singers, mimics and/or puppets.

**"Joint Online Licence"** Means JOINT MCPSI AND IMRO LICENSING SCHEME FOR THE PROVISION OF ONLINE AND MOBILE MUSIC SERVICES TO THE PUBLIC FOR PRIVATE USE

**"Quarter"** means each of the periods from 1<sup>st</sup> January to 31<sup>st</sup> March, 1<sup>st</sup> April to 30<sup>th</sup> June, 1<sup>st</sup> July to 30<sup>th</sup> September, and 1<sup>st</sup> October to 31<sup>st</sup> December, throughout the Term.

**"Realtone"** means a Ringtone incorporating a Repertoire Work (or part thereof) where the sound recording incorporated into such Ringtone consists of a real sound recording as opposed to a ringtone which is a 'polyphonic' or 'monophonic' ringtone (as those terms are commonly understood).

**"Relevant Party"** means a party which is involved in the operation of the Licensee's Ringtones service (in accordance with the terms of this Licence) as set out in clause 10.8.

**"Repertoire Work"** means each Musical Work the relevant copyright in which is owned or controlled, from time to time, in Ireland by:

- (a) MCPSI on behalf of MCPS or a Member or an Associated Society or an Associated Society Member PROVIDED THAT
  - (i) if one or more of those who own or control the copyright in a relevant Repertoire Work is not MCPSI on behalf of MCPS or a Member or an Affiliated Society or Associated Society Member, the expression "Repertoire Work" shall only apply to such interest in the Repertoire Work as is owned or controlled by MCPSI on behalf of MCPS or the Associated Society or the relevant Member or Associated Society Member, and (ii) it shall exclude any Musical Works that a Member of MCPS or an Associated Society has withdrawn or withheld from this Agreement; and
- (b) IMRO or a Member or an Associated Society or an Associated Society Member PROVIDED THAT if one or more of those who own or control the copyright in a relevant Repertoire Work is not IMRO or a Member or an Associated Society or Associated Society Member, the expression "Repertoire Work" shall only apply to such interest in the Repertoire Work as is owned or controlled by IMRO or the

Associated Society or the relevant member or Associated Society Member.

- (c) but excluding in all cases:
  - (i) any Musical Works that the Licensors have notified to the Licensee as being excluded.

For the avoidance of doubt, if a Musical Work is a Repertoire Work in relation to one Licensor and not the other then it remains a Repertoire Work under this Agreement in relation only to the licence granted by that Licensor.

**"Ringtone"** means a short audio recording incorporating a Repertoire Work (or part thereof) the primary purpose of which is to notify the User of an incoming call or message on a Device.

**"Royalty Fee"** means the sum set out in clause 4.

**"Term"** means the period starting on the Commencement Date and ending upon 30 June 2012 unless terminated earlier in accordance with clause 8.

**"Territory"** means Ireland

**User"** means a person who has ordered from the Licensee a Ringtone for a Device for their own private and non-commercial use., or the intended recipient of the Ringtone for their own private and non-commercial use. where that person is different from the person who ordered the Ringtone.

**"VAT"** means value added tax pursuant to the Value Added Tax Act 1972-2004 and each like tax imposed in addition to or in substitution therefor.

## 2. Grant of Licence

2.1 Subject to the terms and conditions contained in this Agreement and conditional upon compliance with such terms and conditions, MCPSI grants to the Licensee on a non-exclusive basis during the Term the right to:

- (a) reproduce Repertoire Works onto servers in the form of Ringtones anywhere in the World solely for the purposes of the Licensee:
  - (i) transmitting the same to Users in the Territory (for private and domestic use); or
  - (ii) providing a free of charge on-demand streamed-only clip to potential Users in the Territory for the purpose of such User previewing the same in deciding whether to purchase a Ringtone; or
  - (iii) providing an IVR service to potential Users in the Territory through which Users are charged via the cost of the telephone call to purchase a Ringtone or potential Users are charged to preview streamed-only clips for the purposes of deciding whether to purchase a Ringtone; and

- (b) reproduce, on a temporary basis only, Repertoire Works in the form of Ringtones anywhere in the World in the form of temporary server or network copies solely for the purposes of the transmission of the Ringtone from the originating server to a User's Device in the Territory
- (c) reproduce or authorise the reproduction of Repertoire Works in the Territory in the form of Ringtones on Users' Devices.

For the avoidance of doubt (but subject to all terms of this Agreement), it is intended that this Agreement licenses all reproductions of Repertoire Works necessary in the ordinary operation of the Licensed Services.

2.2 Subject to the terms and conditions contained in this Agreement and conditional upon compliance with such terms and conditions, IMRO licenses to the Licensee on a non-exclusive basis during the Term the right to:

- (a) make available to the public (as that term is defined in section 40 (1) (a) of the Act (but not for the avoidance of doubt section 40 (1) (b) to (g) inclusive of the Act) in the Territory Repertoire Works in the form of ringtones to Users solely for the purpose of (i) delivering such Ringtone to a User's Device and (ii) allowing a User to preview an on-demand streamed-only clip of a Ringtone in order to decide whether to purchase it; and
- (b) authorising the making available to the public (as that term is defined in section 40 (1) (a) of the Act (but not for the avoidance of doubt section 40 (1) (b) to (g) inclusive of the Act) in the Territory Repertoire Works in the form of Ringtones resulting from the playing in public of Ringtones on Users' Devices as part of the ordinary use of such Devices.

2.3 The Licensee shall use appropriate encryption measures to prevent the unauthorised supply (and any onward-supply from one Device to another) or reproduction of Ringtones incorporating Repertoire Works licensed under this Agreement. The minimum requirement for such encryption measures shall be the so-called 'forward-lock' specifications of the industry standard Open Mobile Alliance DRM version 1.0.

2.4 The Licensee shall comply at all times with the REGTEL Code of Practice (01/11/05 Code of Practice) (or any future edition or code of practice which may replace it) to the extent that the REGTEL Code of Practice is applicable to the Ringtone service; and all applicable codes of practice or guidelines published by REGTEL, or any successor organisation.

2.5 The Licensee shall include the following provisions (or substantially similar provisions) in its terms and conditions for the supply of Ringtones to Users:

- (a) that any Ringtones distributed to Users may only be copied for private non commercial use as a Ringtone or as permitted by applicable law; and
- (b) that, save as may be permitted by law, no attempt shall be made by Users to interfere with, remove or alter any rights management, encryption or identifier information that may be associated with any

Ringtone or any technical measures associated with any Ringtone which are designed to prevent or restrict the unauthorised use of such Ringtone.

The Licensee shall, upon request by the Licensors, supply the Licensors forthwith with a copy of the Licensee's standard terms and conditions applying to the provision of any or all of its Ringtone services.

2.6 The provisions of clauses 3.2, 3.6, 4.1, 4.3 shall not apply to a particular Repertoire Work where the owner of the relevant rights in such Repertoire Work has granted permission to the Licensee for the use of that Repertoire Work on the Licensed Services in the manner described under the relevant clause on such terms and conditions (including, if required, the payment of royalties or fees in addition to those specified under this Agreement) as the owner thinks fit.

### 3. Limitations on Licence

3.1 The licences granted under clause 2 of this Agreement are valid only insofar as the Licensee is the Music Service Provider in relation to the Licensed Services.

3.2 The licences granted under clause 2 of this Agreement do not apply to any Ringtone which incorporates more than 1 minute of a Repertoire Work.

3.3 For the avoidance of doubt, this Agreement does not license the incorporation of Repertoire Works into Audio-Visual Material to be reproduced or made available to the public as a Ringtone and does not include any "synchronisation" licence.

3.4 For the avoidance of doubt, the licences granted under clause 2 of this Agreement shall not authorise the manufacture or distribution of physical products containing Ringtones, such as (without limitation) the distribution of compact discs (or any other type of physical media) incorporating Ringtones.

3.5 Subject to clause 2.6, the licence granted under clause 2.1 of this Agreement shall not permit the use of Repertoire Work(s) with any advertising or sponsorship of whatsoever nature where:

- (a) such Repertoire Work(s) are incorporated into such advertising or sponsorship; or
- (b) such Repertoire Work(s) are otherwise presented in such a way that a reasonable person might associate the Repertoire Work(s) with the advertising or sponsorship.

3.6 Subject to clause 2.6, for the avoidance of doubt (but without prejudice to the generality of clause 3.5), the licences granted under this Agreement shall not apply to any Repertoire Work(s) made available for the purpose of (whether in whole or in part):

- (a) directly or indirectly encouraging the User to purchase or obtain goods or services of whatsoever nature (other than music via the Licensed Service); or
- (b) promoting the branding of the Licensee, any affiliate of the Licensee or any third party;

in such a manner that:

- (i) one or more particular Repertoire Works, composers or writers are associated with such promotion; or
- (ii) a reasonable person might assume that there was an association between particular Repertoire Works, composers or writers and such promotion.

3.7 The licences granted under this Agreement do not apply to any graphic presentation (meaning, without limitation, lyrics, notation or scores) of Repertoire Works.

3.8 Subject to clause 2.6, where any Repertoire Work forms part of any Dramatico-Musical Work, the licence granted under clause 2.1 of this Agreement shall not apply, in relation to Audio-Visual Material, to the reproduction of:

- (a) the whole Dramatico-Musical Work; or
- (b) any excerpt(s) from such Dramatico-Musical Work unless all of the following circumstances apply:
  - (i) that which is copied or made available to the public under this Agreement contains only excerpt(s) within the definition of Permitted Excerpts; and
  - (ii) neither of the Licensors has notified the Licensee in writing that their member or an Associated Society member objects to the reproduction of any such Repertoire Work.

3.9 Subject to clause 2.6, where any Repertoire Work forms part of any Dramatico-Musical Work, the licence granted under clause 2.1 shall not apply, in relation to material other than Audio-Visual Material, to the reproduction of the whole or substantially the whole Dramatico-Musical Work unless:

- (a) the Licensee has specifically notified the Licensors that it wishes to reproduce the whole or substantially the whole work; and
- (b) the Licensors have notified the Licensee that all relevant members consent to such reproduction.

For the purposes of this clause 3.9, the expression "Dramatico-Musical Work" shall include any version of such work (with or without cuts, additions, interpolations or the like) which has been publicly performed. Furthermore, for the avoidance of doubt, substantially the whole work shall be deemed to be reproduced where all or nearly all the individual songs or other music included in the work are reproduced.

3.10 In any event, any licence hereunder only applies to the relevant Repertoire Works and not (by way of example only) to any underlying dramatic or literary work which forms part of the Dramatico-Musical Work or which such Dramatico-Musical Work is based on or uses.

3.11 Subject to clause 2.6, the licences granted under this Agreement shall not extend to or permit any adaptation of any Repertoire Work to be copied or made available to the public as part of a Licensed Service unless the

relevant member has consented to such adaptation. By way of example only, this applies to:

- (a) any sampling (meaning the taking of part of the music and/or lyrics of a Repertoire Work and incorporating such part into another Musical Work) or the making available to the public or reproduction in the form of a sample of such part of a Repertoire Work; or
- (b) using with music lyrics other than those written to be used with the music or authorised for use with the music; or
- (c) using with lyrics music other than that written to be used with the lyrics or authorised for use with the lyrics.

However, subject always to clause 3.17 and provided that such alterations do not amount to an adaptation of a Repertoire Work and do not contravene clause 3.12, then this Agreement shall apply in relation to Repertoire Works that have been modified (including music and/or lyrics) for the purpose of satisfying the requirements of the relevant recording.

Notwithstanding the above, the licences granted under this Agreement do apply to the production and inclusion in a Ringtone of (i) clips of Repertoire Works of up to 60 seconds and (ii) Repertoire Works in a form excluding lyrics.

3.12 Subject to clause 2.6, the licences granted under this Agreement shall not extend to:

- (a) the reproduction or making available to the public of any Repertoire Work or part thereof in the form of a parody or burlesque of any Repertoire Work or of any composer or writer of any Repertoire Work or any band or other group of artists which includes any composer or writer of any Repertoire Work; or
- (b) the use of any Repertoire Work in any context which the Licensee ought reasonably to consider as being likely to be insulting or detrimental to the composer featured on the commercially released sound recording of the music or the relevant member or Associated Society member.

Without prejudice to (i) the Licensors' right to remove certain Musical Works within their repertoire from the Repertoire Works to be licensed under this Agreement and (ii) the moral rights of the composers and writers of Repertoire Works, monophonic and polyphonic Ringtones which incorporate versions of Repertoire Works will not ordinarily be a breach of (a) or (b) above.

3.13 Any additional limitations in relation to Associated Societies' rights to grant the licences set out in clause 2 of this Agreement which have been notified to the Licensors shall be notified to the Licensee in writing (which may include by email) and shall be binding no less than 10 days following such notice. Where any restriction of a material or adverse nature is added, the Licensee shall have the right to terminate this Agreement by giving written notice to the Licensors.

3.14 All rights not specifically granted under this Agreement are hereby reserved.

3.15 This Agreement only covers Repertoire Works. It does not extend to other rights or interests, including (by way of example only), rights in sound recordings, films, dramatic works or performers' rights. The Licensee is required to obtain the appropriate waivers, consents and/or licences from the person(s) owning or controlling rights in relation to sound recordings containing Repertoire Works or performers of that Repertoire Work.

3.16 It is the responsibility of the Licensee to obtain all necessary licences in relation to any Musical Work which is not, or to the extent that it is not, a Repertoire Work, and no licence is granted under this Agreement in relation thereto.

3.17 Nothing in this Agreement affects the moral rights of authors of Repertoire Works whether subsisting within or outside Ireland or any other territory.

#### **4. Royalty Fees**

4.1 In consideration of the licence granted under this Agreement, the Licensee shall pay to the Licensors:

- (a) the Quarterly Advance; and
- (b) subject to clause 4.3, the Royalty Fee.

4.2 The Royalty Fee shall be:

- (a) in respect of Realtones, the greater of:
  - (i) 12% of Applicable Revenue; and
  - (ii) €0.17 cent in respect of each such Realtone downloaded by a User; or
- (b) in respect of all Ringtones other than Realtones, the greater of:
  - (i) 15% of Applicable Revenue; and
  - (ii) €0.26 cent in respect of each such Ringtone downloaded by a User.

4.3 The Quarterly Advance is recoupable against the Royalty Fee. If any part of the Quarterly Advance remains unrecouped at the end of a Quarter, such unrecouped amount may be carried over to subsequent quarters, but for the avoidance of doubt, shall not (except as set out in clause 4.5 below) have the effect of reducing any subsequent Quarterly Advance. If any part remains unrecouped upon termination or expiry of the Agreement, the Licensors shall return such part to the Licensee.

4.4 The Licensee shall be entitled to provide free streaming-only clips of a Ringtone of duration up to 30 seconds duration (without payment of any minimum royalty (as referred to in clauses 4.2(a) (ii) and 4.2 (b) (ii) provided that such clip is used solely to promote the sale of such Ringtone by the Licensee. However and for the

avoidance of doubt, any revenue falling within the definition of Gross Revenue which is received (or receivable) as a result of such activity which is received (or receivable) shall be included for the purposes of calculating royalties due under this Agreement.

- 4.5 The Quarterly Advance is intended to represent the expected royalties due for each Quarter. The Quarterly Advance shall be reviewed at the end of each calendar year. It may also be reviewed during a calendar year if the royalties calculated for any particular Quarter under Schedule 2 differ from the Quarterly Advance by 20% or more.
- 4.6 Where, in relation to any particular Quarter, the Licensee fails to provide by the required date the information required under the Agreement to allow the calculation referred to in clause 4.2, then the Licensors shall be entitled to fix the Royalty Fee based on (a) the Royalty Fees payable in previous Quarters and (b) any other relevant factors which could reasonably lead the Licensors to believe that the Royalty Fees payable would be materially different to those paid or payable in previous Quarters.
- 4.7 The licence fees referred to in clause 4.1 are subject to VAT or other equivalent sales tax if applicable. The Licensee shall pay to the Licensors VAT (or other tax where applicable) at the rate or rates from time to time in force on any sums payable under this Agreement.
- 4.8 Insofar that (i) a Musical Work is not in copyright in the relevant part of the Territory, or (ii) it is not a Repertoire Work, credit shall be given by either or both of the Licensors (as the case may be) for any overpayment of royalties. The parties shall discuss in good faith the mechanism for calculating and granting any rebate for Musical Works which are not Repertoire Works. Unless and until agreed otherwise, the terms set out in this Agreement shall apply, it being acknowledged by the Licensors that it may then be necessary to make adjustments to payments that have already been made by the Licensee to the Licensors as and from the Commencement Date so as to allow for royalties paid on Musical Works that are not Repertoire Works.

#### **5. Payment of Royalty Fees**

- 5.1 The Quarterly Royalty Fee shall be payable on the first day of each Quarter. Where the Commencement Date is not the first day of a Quarter, the first Quarterly Royalty Fee payment shall be pro-rated (according to the Commencement Date).
- 5.2 Within 21 days of the end of each Quarter the Licensee shall provide to the Licensors (at the address notified by the Licensors to the Licensee) a fully and accurately completed Accounting Statement.
- 5.3 If the Royalty Fee for any given Quarter exceeds the Minimum Quarterly Royalty Fee, then the Licensors shall send the Licensee an invoice for the required additional licence fees in respect of that Quarter. The Licensee shall pay such amount to the Licensors within 31 days of

the date of such invoice. If, in respect of a Quarter, the Licensee is late in submitting a fully and accurately completed Accounting Statement or Music Usage Information, the Licensors shall be entitled to reduce the period for payment of any additional licence fees for that Quarter by a corresponding period of time.

- 5.4 Without prejudice to any other right or remedy of the Licensors, and without imposing an obligation to accept late payment, where any fees payable under this Agreement are not paid by the due date, the Licensee shall pay interest on such late payment calculated on a daily basis at an annual rate of 3% over the prime overdraft rate, current from time to time, of Bank of Ireland payable from the date on which the payment should have been made to the date on which the payment was made.

## 6. Reporting

- 6.1 In relation to any and all Repertoire Works reproduced and made available to the public in the form of Ringtones under this Agreement, the Licensee will deliver the Music Usage Information to the Licensors or to the Licensors' duly authorised agent (details of which will be provided to the Licensee) quarterly within one month of the end of the Quarter to which reporting relates.
- 6.2 The Licensee must also supply the Licensors with any further information or documentation in its possession, power, custody or control (and use its reasonable endeavours to supply the Licensors with any further information or documentation not in its possession, power, custody or control) reasonably requested by the Licensors at any time, in order to enable the Licensors to verify the Repertoire Work(s) which have been made available reproduced or distributed via all Licensed Services.
- 6.3 Where Ringtones are accessible by Users only on payment of subscription or other similar payment (or access is otherwise limited or controlled in some way), the Licensee shall, upon request of the Licensors, use reasonable endeavours to ensure that such Ringtones are at all times accessible by the Licensors free of charge for the purposes of the Licensors verifying that the Licensee is acting in accordance with this Agreement. For the avoidance of doubt, the Licensee shall not be required to provide free Ringtones to the Licensors.
- 6.4 The Licensee acknowledges that the Licensors have a responsibility to maximise the efficiency of their reporting to their members and Associated Societies. Therefore, if the Licensors wish to make any reasonable upgrade or alteration of whatsoever nature to the Music Usage Information or data specification referred to in Schedule 3 during the Term, the Licensee agrees to use its reasonable endeavours to implement the changes required as soon as is reasonably practicable, PROVIDED THAT the Licensors shall not request that the Licensee implements the change in less than six months from the making of the request, and in each case of a change the following procedures shall apply:
- (a) the Licensors shall give full details thereof in writing to the Licensee;

- (b) the Licensee will respond in writing within 4 weeks of receipt of the request, stating the date by which it commits to comply with the change and the Licensors shall provide full assistance to the Licensee in order to assist the Licensee in complying with the change; and

the parties will then finalise the details and undertake tests to ensure that the change operates satisfactorily within the terms of this Agreement, satisfactory operation of which will be deemed acceptance of the change and/or the definition of Music Usage Information will be amended or replaced accordingly. For the purpose of this clause, in determining what change may be reasonable, regard shall be had to the DDEX project.

- 6.5 Without prejudice to any right in law that the Licensors may have to obtain such information, the Licensee shall not be obliged to provide to the Licensors any information which identified Users or which otherwise constitutes "personal data" as defined in the Data Protection Acts 1988 and 2003. For the avoidance of doubt, the Licensee must still provide all required Music Usage Information or other information to be provided under this Agreement but is entitled to remove any element of it which reveals the identity of Users or otherwise causes it to constitute "personal data".

## 7. Auditing

- 7.1 The Licensee shall keep and make available for inspection upon not less than 30 days' notice (and shall procure that each Relevant Party keeps and makes available for inspection upon reasonable notice), both during and for twelve months after termination of this Agreement, proper, detailed books and records relating to (a) the use of all Musical Works and whether the use thereof is in accordance with the terms of this Agreement, and (b) any income or other consideration received by or on behalf of the Licensee in relation to the Licensed Services, together with any supporting documentation relating thereto covering the period up to six years prior to the date of notification of audit.
- 7.2 For the purposes of this clause 7, the Licensee shall allow during normal business hours and upon not less than 30 days' notice (and shall procure that each Relevant Party shall allow) access to its premises to inspect relevant accounting records, but not more than once per annum. The duly authorised representatives (who shall be external qualified accountants or auditors unless otherwise agreed between the parties) of the Licensors shall have such access to the Licensee's premises and shall be entitled to inspect, make extracts and take copies of any of the information and/or documentation available and to carry out such work as is, in their reasonable opinion, considered necessary to verify compliance with the provisions of this Agreement.
- 7.3 If tests under any audit and verification process indicate under-payment of the correct Royalty Fee during the period under audit, then, without prejudice to the Licensors' other rights under this Agreement, the Licensee shall pay the amount of the underpayment plus interest based on the period from which the correct fee should have been paid to the Licensors to the date when it was actually paid (at the rate set out in clause 5.4).

- 7.4 If any audit and verification process discloses (a) under-payment of more than 7.5% of the correct Royalty Fee during the period under audit and/or (b) failures to report correctly (so as to affect a distribution by the Licensors to their Members) amounting to at least 7.5% of the music usage during the period under audit, then, without prejudice to the Licensors' other rights under this Agreement, the Licensee shall pay, in addition to the payment referred to in clause 7.3, the Licensors' reasonable costs of such audit and verification within 28 days of receipt of the Licensors' VAT invoice therefor.
- 7.5 If tests under any audit and verification process indicate over-payment of the correct Royalty Fee during the period under audit, then the Licensors shall, as soon as is reasonably practical, pay the amount of the overpayment back to the Licensee (but, for the avoidance of doubt, no interest shall be payable unless the overpayment is a result of an act or omission of the Licensors (in which case interest shall be payable at the rate set out in clause 5.4). However, where the overpayment does not result from an act or omission of the Licensors and the Licensors have already distributed such overpayment to their members and/or their Associated Societies, the Licensors shall be entitled to deduct its reasonable internal and/or external costs in administering the payment back of the overpayment.
- 7.6 The Licensors shall not (and shall procure that their representatives shall not), without the Licensee's written consent, disclose to any third party any confidential information of the Licensee (so long as it remains confidential) received in the course of an audit carried out under this clause 7, save that such confidential information may be disclosed to the Licensors' directors, board sub-committee members, officers, employees and professional advisors (solely where such persons are under a duty of confidentiality in relation to information so received and the Licensors shall be liable to the Licensee in respect of any breach of such confidentiality obligation) solely for purposes connected with this Agreement.
- 7.7 For the avoidance of doubt, books, records and accounting records as referred to in clauses 7.1 and 7.2 above shall include data, information and records held on computers.
- 7.8 The Licensee shall, if requested by the Licensors, provide a statement from its auditors (but not more than once per year) confirming that the financial information submitted by the Licensee for the relevant requested period is in accordance with the actual Gross Revenue (as defined under this agreement) for that period. Such statement will be at the Licensees cost, not the Licensors.
- 8. Termination and effect of termination**
- 8.1 This Agreement may be terminated by either party by the terminating party giving the other party not less than three months notice in writing.
- 8.2 Either party shall have the right to terminate this Agreement immediately by written notice to the other party if:
- (a) the other commits a material breach of this Agreement which is not capable of remedy; or
  - (b) the other commits a material breach of this Agreement which is capable of remedy but which has not been so remedied within 14 days of notice thereof; or
  - (c) the other goes into examinership, receivership or any resolution is passed for its winding-up or liquidation (other than for the purposes of reconstruction or amalgamation) or is otherwise unable to pay its debts.
- 8.3 Upon termination of this Agreement all licences granted hereunder shall terminate and the Licensee shall immediately cease to be licensed by the Licensors for the reproduction or making available to the public of Ringtones containing Repertoire Works. Termination shall be without prejudice to the ability of Users to retain a copy of a Ringtone supplied to them prior to the date of termination.
- 8.4 Clauses 4, 5, 6, 7 and 9 shall survive the termination of this Agreement, but only in relation to the Licensee's activities during the Term.
- 9. Notices**
- 9.1 Except where expressly stated otherwise, any notice or other written communication given under or in connection with this Agreement shall only be effective if it is in writing. Faxes and e-mails are permitted. In the absence of any legitimate electronic signature system, either party shall be permitted to require the confirmation in writing (signed by an authorised signatory) of any notice originally sent by email
- 9.2 The address for service of any party shall be its registered office marked for the attention of the Chief Executive or Managing Director, or, if any other address or addressee for service has previously been notified to the server, to the address so notified. A single notice served on or sent to either Licensor shall be treated as validly served on both Licensors.
- 9.3 Any such notice or other written communication shall be deemed to have been served:
- (a) if personally delivered, at the time of delivery;
  - (b) if posted, at the expiry of two business days or in the case of airmail four business days after it was posted;
  - (c) if sent by facsimile message or e-mail, at the time of receipt of transmission (if received during normal business hours that is 09. 00 to 17.00 local time) in the place to which it was sent or (if not received during such normal business hours) at the beginning of the next business day at the place to which it was sent.
- 9.4 In proving service of a notice it shall be sufficient proof that personal delivery was made, or that such notice or other written communication was properly addressed stamped and posted or in the case of a facsimile message or e-mail that an activity or other report from the sender's facsimile machine or computer can be produced in respect of the notice or other written communication, in

the case of a fax, showing the recipient's facsimile number and the number of pages transmitted.

## 10. Miscellaneous

10.1 The parties shall (and shall procure that any other necessary party within its control shall) execute all such documents and do all such acts and things as may reasonably be required on or subsequent to completion of this Agreement for securing each of the obligations of the respective parties under this Agreement.

10.2 This Agreement has been granted by the Licensors on the basis of the representations made by the Licensee in the process of applying for this Agreement, and in particular the information provided by the Licensee in the application form. If any of those representations are materially incorrect, the licence granted under this Agreement shall not apply. The Licensee must notify the Licensors immediately of any material changes in any of the facts and matters express or implied set out in the answers to the application form' and the licence granted under this Agreement shall not apply in any such case unless the Licensors agree otherwise in writing. For the avoidance of doubt, the Licensee seeking to supply Ringtones via additional services, clients or websites (to those included on the original application form) shall be deemed to be a 'material change'.

10.3 This Agreement sets forth the entire agreement of the parties in relation to the subject matter hereof and each of the parties hereto acknowledges that it has not entered into this Agreement in reliance on any representation or term not contained herein. This Agreement shall not be modified or varied.

10.4 Except as set out in clause 10.5 below, this Agreement is personal to the Licensee and the Licensee must not assign, sub-license or otherwise transfer any of its rights or obligations under this Agreement whether in whole or in part without the prior written consent of the Licensors.

10.5 Subject always to the other provisions of this Agreement, the Licensee shall be permitted to use the services of a third party in operating its Ringtones services (including the performance of its obligations under clause 6 above) provided that:

- (a) the Licensee retains complete control and direction over the provision of Ringtones to Users; and
- (b) the Licensors are able to audit such third party in accordance with clause 7 above.

10.6 No party to this Agreement shall be liable to the other parties for any failure to perform any or all of its obligations hereunder due to or attributable to acts, events, omissions or accidents beyond the reasonable control of the defaulting party, including a so-called act of God, fire, lockout, strike or other official labour dispute, union problem, riot or civil commotion, terrorism, satellite failure, failure of technical facilities not within the reasonable control of the defaulting party, act of public enemy, enactment, rule or order or act of government, such act or event being deemed an event of force majeure. Each party to this Agreement undertakes to use all reasonable endeavours to notify the other parties as

soon as practicable of the incidence and termination of any event or force majeure.

10.7 No delay or omission in exercising any right or remedy hereunder shall operate as a waiver thereof or of any other right or remedy and no single or partial exercise thereof shall preclude any other or further exercise thereof or the exercise of any other rights or remedies. No waiver shall be binding or effectual for any purpose unless expressed in writing and signed by the party giving it and any such waiver shall be effective only in the specific instance and for the purpose given.

10.8 If this Agreement creates any rights which would in the absence of this provision be enforceable by any person not a party to this Agreement, such rights shall not be enforceable.

10.9 This Agreement shall be construed according to the laws of Ireland and the parties agree to submit to the jurisdiction of the Irish Courts.

### SCHEDULE 1

#### Definition of Gross Revenue

1. "Gross Revenue" means, subject to the provisions of this Schedule:

(a) all revenue received (or receivable) by the Licensee from Users (and other purchasers of Ringtones if not Users), whether in the form of a la carte or subscription payments (including, but not limited to, sign-up and termination fees for subscriptions and so-called "ringtone clubs"), in consideration for the provision of Ringtones (including revenue received (or receivable) in consideration for the browsing of available Ringtones on a premium rate telephone line and also including revenue received (or receivable) when the Ringtone is not actually delivered provided no refund has been made); and

(b) all revenue, including by way of sponsorship and commissions, received (or receivable) by the Licensee as a result of the inclusion of third party advertising "in-stream" or "in-download" as part of a Ringtone, being advertising placed immediately at the start, end or during the actual delivery (by way of streaming as a "preview" clip or downloading as applicable) of a Ringtone to a User; and

(c) all revenue, including by way of sponsorship and commissions, received (or receivable) by the Licensee as a result of the inclusion of third party advertising heard by a User when choosing and/or ordering a Ringtone through any telephone based ringtone ordering service (for example, a service by which ringtones are ordered using a standard or premium rate telephone and/or IVR service); and

(d) all revenue, including by way of sponsorship and commissions, received (or receivable) by the Licensee as a result of the placement of third party advertising on a Relevant Page (as defined below) and any page which directly follows such Relevant Page, the User having selected to download a Ringtone (or stream a preview clip), leading up to and



including the downloading or streaming of the Ringtone;

and in each of the above cases such revenue shall, for the avoidance of doubt, include any such revenue whether received or receivable by the Licensee or any associate, affiliate, agent or representative of such party.

The Licensee shall notify the Licensors promptly of its intention to first introduce advertising or sponsorship within its Ringtone service where it would give rise to revenue falling within (b), (c) or (d) above.

2. **“Relevant Page”** means a page:
  - (a) from which Ringtones (whether for download or streaming as preview clips) are “actually offered” to Users. A Ringtone is “actually offered” to Users from a page if Ringtones are enabled or made directly available (for preview or download) from that page to the User to download or stream from that page (in most cases this will be where such Ringtones can be purchased by the User or their download or stream otherwise takes place); but only:
  - (b) where such offering of Ringtones forms all or the predominant part of that page, being for the purposes of this Agreement where the offering comprises 75% or more of the space on that page excluding space occupied by any advertising. For the purposes of performing the foregoing calculation, the “offering” shall include any content which directly relates to the actual offering of the Ringtone pursuant to subparagraph (a) above (by way of example, but without limitation, an image of the artist or artwork closely associated with the offering, reviews of the offering, credits, and, where applicable, music player controls).
3. Where content “actually offered” from a single page includes a combination of Ringtones and content licensable under the Joint Online Licence operated by the Licensors (for which the Licensee is the party required to hold a licence from the Licensors) (“mixed content”), the definition of Relevant Page set out in paragraph 2 above shall be modified to include all content under this Agreement and that Joint Online Licence in calculating whether the offering of Ringtones and content licensable under the Joint Online Licence together comprises 75% or more of the space on the single page. Where mixed content does comprise 75% or more of the space on the page, the royalty rate (in relation to all of the mixed content on that Relevant Page) shall be 10% of the Applicable Revenue (in respect of revenue falling within paragraph 1(d) above) unless either party can show that a different rate should reasonably apply. When determining whether another rate should reasonably apply, the parties may have regard to the relative amount of mixed content on the Relevant Page (as between Ringtone and other content under the Joint Online Licence)
4. Where Realtones and no other type of Ringtone are offered from a Relevant Page the royalty rate shall be 12% of Applicable Revenue (in respect of revenue falling within paragraph 1(d) above).
5. Where Ringtones other than Realtones and no Realtones are offered from a Relevant Page the royalty rate shall be 15% of Applicable Revenue (in respect of revenue falling within paragraph 1(d) above).
6. Where Realtones and other types of Ringtones are offered from a single Relevant Page and no other content licensable under the Joint Online Licence operated by the Licensors (for which the Licensee is the party required to hold a licence from the Licensors) appears on that Relevant Page, the royalty rate shall be 13.5% of the Applicable Revenue (in respect of revenue falling within paragraph 1(d)) unless either party can show that a different rate should reasonably apply.
7. For the avoidance of doubt, in relation to paragraphs 3 to 6 above, the royalty rate in respect of Applicable Revenue other than that falling within paragraph 1(d) above should be the royalty rate applicable to that type of content.
8. Where Ringtone content is offered from a page together with other content licensable by MCPSI and/or IMRO to the Licensee (except for content licensable under the Joint Online Licence), the parties will enter good faith discussions to determine, in respect of such content, how the royalty rate should be determined in relation to revenue gained from advertising on that page.
9. Subject to the remainder of this schedule 1, there shall be no other deduction or set-off from the above revenues other than refunds to Users for services that they were unable to use due to technical faults in the Licensed Services.
10. The Licensors confirm that no revenue which is included in Gross Revenue under this Agreement shall form any part of the “revenue base” under any other licence or licensing scheme operated by the Licensors (or either of them) which grants all or some of the rights set out in clauses 2.1 and 2.2 of the main body of this Agreement (albeit in relation to a service other than for the supply of Ringtones).
11. For the further avoidance of doubt, revenue which relates solely to services other than the supply of Ringtones shall not be included in the Gross Revenue. By way of example, this includes:
  - (a) revenue derived from non-Ringtone voice, content and text services;
  - (b) revenue derived from music or music-related services which are not licensable under this Agreement; or
  - (c) revenue derived from non-Ringtone products and services (including search services) supplied by the Licensee.

For the avoidance of doubt, the above is without prejudice to the requirement to include within Gross

Revenue all “browsing” revenue generated through a premium rate telephone line service as referred to in paragraph 1(a) above.

12. For the further avoidance of doubt, Gross Revenue shall not be reduced by credit card commissions or similar payment process charges.
  13. Gross Revenue obtained in the form of advertising or sponsorship revenue shall be reduced by 5% to reflect the costs of obtaining it.
  14. For the avoidance of doubt, advertising revenue referred to in paragraph 1(d) of this schedule 1 above shall not include revenue arising from sponsored searches or click-through commissions arising from such searches.
  15. (a) Where a service offering Ringtones (for the purposes of this clause “Service A”) is provided to Users in conjunction with another service (for the purpose of this clause “Service B”), then the price deemed to be payable by Users (“the User Price”) for the Ringtone(s) (for the purpose of calculating Gross Revenue) shall be calculated in accordance with this paragraph 15.
    - (b) Where there are separate bona fide published prices for Service A and Service B when available alone, then the User Price shall be the proportion of the bundled price represented by the relative standalone prices for Service A and Service B, subject to “weighting” to be carried out in accordance with example 16(c) below.
    - (c) Where there are no separate published prices for Service A and Service B, then the User Price shall be deemed to be the proportion of the bundled price represented by the relative bona fide standalone prices for comparable Irish services for Service A and Service B subject to “weighting” to be carried out in accordance with example 13(c) below. If there is more than one comparable service, then the average shall be used.
    - (d) If there are no comparable Irish standalone services for Service A and Service B, then the applicable minimum royalties (as referred to in clauses 4.2 (a) (ii) and 4.2 (b) (ii) of the main body of this Agreement) shall be payable.
    - (e) For the avoidance of doubt, where the User Price is set according to either of paragraphs (b) and (c) above, the royalty payable shall be the higher of the applicable royalty rate applied to the User Price and the applicable minimum royalties.
    - (f) The provisions of paragraph 17 below shall apply if any dispute arises in relation to the application of the provisions of this paragraph 15 as to whether and if so at what level the User Price shall be set pursuant to paragraphs (b) and (c) above.
13. The following are non-exhaustive examples of the application of this Schedule 1 to various scenarios:
- (a) A Ringtone is delivered to a User, but the payment is not collected by the Licensee: The Royalty Fee is calculated as per clause 4.2 of the main body of the

Agreement and the price that the User (or purchaser) should have paid will be included in the Gross Revenue.

- (b) A Ringtone is not delivered to a User but the price of the Ringtone is received by the Licensee from the User (or purchaser) and not subsequently refunded: The Royalty Fee is calculated as per clause 4.2 of the main body of the Agreement and the price that the User (or purchaser) paid will be included in the Gross Revenue.
  - (c) Ringtones (and other content) are offered as part of a subscription package whereby for a fee of, for example, €3.00 a week, a User (or purchaser) may download a mixture of Ringtones and/or other content up to set limits during each a week: The provisions of paragraph 6 above are applied to calculate the Gross Revenue. The following example illustrates how this process would operate:

A service offers a subscription of €3 per week (excluding VAT), for which consumers get 5 credits to redeem against content. Any credits not redeemed within the week are lost.

Ringtones cost 3 credits & wallpapers cost 1 credit.

At the end of the Quarter the Licensee has sold 100,000 Ringtones and 30,000 wallpapers and generated €600,000 in revenue.

The unbundling of the revenue would take place as follows:

    - (i) Content is weighted to account for value within the bundle:  
Ringtones (3 credits) = 100,000 x 3 = 300,000  
Wallpapers (1 credit) = 30,000 x 1 = 30,000  
Total = 330,000
    - (ii) Revenue is pro-rated in accordance with content recouped within the period:  
 $Gross\ Revenue = €600,000 / 330,000 = 1.82$   
 $Ringtones = 300,000 \times 1.82 = €546,000$

The Gross Revenue for the purposes of calculating royalties due within the content bundle = €546,000.
  - (d) Ringtones (but no other content) are offered as part of a subscription package whereby for a fee of, for example, €3.00 a week (excluding VAT), a User (or purchaser) may download up to two Ringtones a week: The €3.00 fee is always included in the Gross Revenue regardless of whether any Ringtones are actually downloaded during any particular week.
  - (e) Revenue is received (or receivable) through an IVR system as a result of Users (or purchasers) browsing for Ringtones: Such revenue is included in the Gross Revenue whether or not any Ringtone is actually chosen to be downloaded by the User (or purchaser).
14. (a) The provisions of this paragraph 17 shall apply if a dispute (a “Dispute”) arises in relation to the application of the provisions of this Schedule 1 as to

what revenue is included within the definition of Gross Revenue

- (b) Provided that the Licensors and the Licensee shall have held substantive negotiations in good faith regarding the subject matter of the Dispute over a period of at least 21 days from the date on which the Licensors notify the Licensee or the Licensee notifies the Licensor (as the case may be) in writing of the existence of such Dispute, the Licensors or the Licensee shall then be entitled by notice in writing from the Licensors to the Licensee or by Licensee to the Licensors to refer the Dispute for determination to an independent arbitrator acting as an expert. The identity of such expert shall either be agreed or, in the absence of such agreement within 7 days of the written notice of referral, shall be determined by the President for the time being of the Institute of Chartered Accountants in Ireland, and shall be an independent chartered accountant, unless the Licensors and the Licensee agree that another type of expert would be more suitable to determine such Dispute. The Licensors and the Licensee will seek to agree the procedure for the conduct of any expert determination. If such agreement is not reached within 7 days of the appointment of the expert, the expert shall have power to set the procedure for the expert determination. The expert shall make his determination as soon as reasonably practicable. The expert shall have power to award costs in the expert's determination, unless the Licensors and the Licensee agree otherwise. The decision of the expert is final and binds the parties to the Dispute unless there is manifest error, wilful default or fraud. For the avoidance of doubt, it is hereby confirmed that the expert shall have no jurisdiction to amend any term of the Agreement.



**Schedule 2**

**Form of Accounting Statement**

MCPSI-IMRO Ringtones Revenue Reporting form

**MCPSI-IMRO Ringtones Revenue Reporting Form**

**Company Name:**  
**Contact Name:**  
**Quarter**  
**Quarterly Fee**

**Type of Service**

**SERVICE NAME**

--

**SERVICE TYPE (A LA CARTE / SUBSCRIPTION)**

--

**REVENUE DECLARATION**

*Insert details of the applicable price points (Exc .VAT) in the grey boxes (including free tones under the price point €0.00) and the applicable levels of revenue (including any applicable indirect revenue) at each price point in the boxes below*

**Mono/PolyTone Revenue at 15%**  
**RealTone Revenue at 12%**  
**Revenue at 13.5% (Mixed Mono-Poly/Real Ringtone Revenue)**  
**Revenue at 10% (Mixed Ringtone-JOL Revenue)**  
**Other Revenue at [ ]%**

Price Points (Exc. VAT)		
€	€	€
€	€	€
€	€	€
€	€	€
€	€	€
€	€	€

**USAGE DECLARATION**

*Insert details of the applicable price points (Exc .VAT) in the grey boxes (including free tones under the price point €0.00) and the applicable levels of usage at each price point in the boxes below*

**No. of Mono/PolyTones Sold at each Price Point**  
**No. of RealTones Sold at each Price Point**

Price Points (Exc. VAT)		
€	€	€
€	€	€
€	€	€

**Schedule 3**

**Music Usage Information**

IMRO MCPSI Reporting Format

To be agreed with Licensee

<b>JOINT MCPSI AND IMRO PODCASTING LICENCE</b>	
--	--

NAME OF LICENSEE	(“the Licensee”)
COMPANY REGISTRATION NUMBER OF LICENSEE	
REGISTERED ADDRESS OF LICENSEE	
LICENSED SERVICE	(“the Licensed Service”)
COMMENCEMENT DATE	(the “Commencement Date”)
QUARTERLY ADVANCE	(the “Quarterly Advance”)

This scheme is offered on a strictly non-precedential basis. MCPSI and IMRO may not consider that the current terms and conditions are appropriate following expiry of this scheme and MCPSI and IMRO reserve the right at that time to propose different terms and conditions to those of this scheme.

**Signed for and on behalf of the Licensee:**

\_\_\_\_\_ **Date:** \_\_\_\_\_

**Signed for and on behalf of MCPSI:**

\_\_\_\_\_ **Date:** \_\_\_\_\_

**Signed for and on behalf of IMRO:**

\_\_\_\_\_ **Date:** \_\_\_\_\_

# JOINT PODCASTING LICENCE

## TERMS AND CONDITIONS

### 1. Definitions

**"Act"** means the Copyright and Related Rights Act 2000 as amended from time to time.

**"Agreement"** means these terms and conditions, the schedules to these terms and conditions and the application form completed and signed by the Licensee.

**"Associated Society"** means each collecting society (or other body representing rights in Musical Works) with which MCPS and/or IMRO has, from time to time, an agreement under which MCPS and/or IMRO is authorised to grant licences in relation to the other society's (or body's) repertoire for the purpose of this Agreement PROVIDED THAT where such an agreement is only entered into after the commencement of the Term, a collecting society (or other body) shall only be regarded as an "Associated Society" for the purposes of this Agreement with effect from the date of signature of such agreement with MCPS and/or IMRO (as applicable).

**"Associated Society Member"** means any person, firm or company who or which has been notified, from time to time, as being a member of an Associated Society by the relevant Associated Society to MCPS and/or IMRO.

**"Commencement Date"** means the date specified in the cover sheet.

**"Commercial Work"** means any Repertoire Work other than:

- (a) one where the Member owning or controlling the copyright in such Repertoire Work has authorised MCPSI to license it as so-called production or library music; or
- (b) a Commissioned Work, PROVIDED THAT for the purposes of clause 4.3, a Commissioned Work shall not be excluded from such definition where the commissioning agreement does not authorise the Licensee to use the Commissioned Work in the context set out in those clauses.

**"Commissioned Work"** means a Musical Work specially and expressly commissioned by the Licensee from composer/writer members of IMRO and/or MCPS.

**"Data Storage Device"** means any medium on which data can be stored (whether temporarily or permanently) whether existing now or invented in the future.

**"Electronic Reporting Format"** . means the format set out in Schedule 1. If and when the DDEX format is agreed within the industry, the DDEX format shall replace the format set out in schedule 3 within 6 months of such agreement unless otherwise agreed between the parties, acting reasonably

**"Gross Revenue"** shall have the meaning set out in schedule 2.

**"IMRO"** means IRISH MUSIC RIGHTS ORGANISATION CLG whose registered office is at Copyright House, Pembroke Row, Lower Baggot Street, Dublin 2, Ireland ("IMRO") contracting for and on behalf of itself and for and on behalf of and as agents of its Associated Societies

**"Joint Online Licence"** means a licence agreement under the "Licensing Scheme for the provision of Online and Mobile Music Services to the Public for Private Use" as published by the Licensors from time to time.

**"Licensed Service(s)"** means the service(s) set out in the cover sheet.

**"Licensee"** means the party set out in the cover sheet.

**"Licensors"** means IMRO and MCPSI

**"MCPSI"** means MECHANICAL-COPYRIGHT PROTECTION SOCIETY IRELAND LIMITED whose registered office is at Copyright House, Pembroke Row, Lower Baggot Street, Dublin 2, Ireland ("MCPSI") contracting for and on behalf of and as agent of MECHANICAL-COPYRIGHT PROTECTION SOCIETY LIMITED having its registered office at 2<sup>nd</sup> Floor, Synergy House, 114-118 Southampton Row, London, WC1B 5AA, UK and its various Members and the Associated Societies

**"Member"** means:

- (a) in the case of MCPS, each person, firm or company who or which, from time to time, has appointed MCPS as agent in relation to online exploitation either before or during the Term, other than where such person, firm or company has opted not to participate in the licensing scheme pursuant to which this Agreement has been entered into, PROVIDED THAT a member who has so appointed MCPS after the commencement of the Term shall only be regarded as a member for the purposes of this Agreement with effect from the date on which the Member so appointed MCPSI; and
- (b) in the case of IMRO, any person, firm or company who or which, from time to time, pursuant to the Articles of Association of IMRO has been admitted either before or during the Term as a member of IMRO PROVIDED THAT a member who has been so admitted after the commencement of the Term shall only be regarded as a member for the purposes of this Agreement with effect from the date of admission into IMRO.

**"Month"** means a calendar month.

**"Music Podcasting Service"** means a service (or the relevant part of a service) whereby Podcasts (as opposed to individual Musical Works) containing music may be made available to the public via a Network to Users such that Users may retain a copy of such



Podcast on their Data Storage Devices (whether permanently or temporarily).

**“Musical Work”** means any musical work (as defined in the Act) and any lyrics or words written to be used with such musical work (if applicable). It includes any part of such a work.

**“Music Service Provider”** means, the party which, in relation to a Music Podcasting Service, most closely meets the following criteria:

- (a) contracts with the User in relation to the provision of the Licensed Service;
- (b) sets and controls the price the User pays;
- (c) can fully report on all elements of Gross Revenue (including relevant advertising revenues);
- (d) can fully report on all elements of music usage (or can procure such reporting);
- (e) controls how content is offered and bundled within the Licensed Service; and
- (f) carries out or authorises, on their instruction, the carrying out of the copyright restricted acts licensed under this Agreement.

**“Music Usage Information”** means the information referred to in the Electronic Reporting Format.

**“Network”** means the internet, a mobile network or any other wired or wireless network.

**“Podcast”** means a downloadable, audio only programme that contains both music and speech where the Podcast cannot be disaggregated into its individual tracks. .

**“Quarter”** means each of the periods from 1st January to 31st March, 1st April to 30th June, 1st July to 30th September, and 1st October to 31st December, throughout the Term.

**“Quarterly Advance”** means the sum set out in the cover sheet, excluding VAT (or other equivalent sales tax, as applicable) which shall be not less than €100 per quarter (plus VAT).

**“Quarterly Royalty Statement”** means the document supplied by the Licensors to the Licensee quarterly to be completed by the Licensee and returned to the Licensors in accordance with clause 5.6 below.

**“Relevant Party”** means a party which is involved in the provision of the Licensed Services, as set out in clause 14.2.

**“Repertoire Work”** means each Musical Work the relevant copyright in which is owned or controlled, from time to time, in Ireland by:

- (a) MCPSI on behalf of MCPS or a Member or an Associated Society or an Associated Society Member PROVIDED THAT

(i) if one or more of those who own or control the copyright in a relevant Repertoire Work is not MCPSI on behalf of MCPS or a Member or an Associated Society or Associated Society Member, the expression "Repertoire Work" shall only apply to such interest in the Repertoire Work as is owned or controlled by MCPSI on behalf of MCPS or the Associated Society or the relevant Member or Associated Society Member, and (ii) it shall exclude any Musical Works that a Member of MCPS or an Associated Society has withdrawn or withheld from this Agreement; and

(b) IMRO or a Member or an Associated Society or an Associated Society Member PROVIDED THAT if one or more of those who own or control the copyright in a relevant Repertoire Work is not IMRO or a Member or an Associated Society or Associated Society Member, the expression "Repertoire Work" shall only apply to such interest in the Repertoire Work as is owned or controlled by IMRO or the Associated Society or the relevant member or Associated Society Member.

(c) but excluding in all cases any Musical Works that the Licensors have notified to the Licensee as being excluded.

For the avoidance of doubt, if a Musical Work is a Repertoire Work in relation to one Licensor and not the other then it remains a Repertoire Work under this Agreement in relation only to the licence granted by that Licensor.

**“Reporting Date”** means one Month following the Quarter to which the Music Usage Information relates.

**“Royalty Fees”** means the royalties payable as set out in clause 5.

**“Server Territory”** means the European Economic Area, Switzerland, the United States of America, Canada and such other territories as may be agreed in writing by the parties.

**“Term”** means the period starting on the Commencement Date and ending upon the date set out in clause 11.1 (unless terminated earlier under clauses 11.2 or 11.3).

**“Territory”** means Ireland

**“User”** means a natural person in the Territory who receives the Licensed Services for their own private and non-commercial use.

**“VAT”** means value added tax pursuant to the Value Added Tax Act 1972-2004 and each like tax imposed in addition to or in substitution therefor.

**“Week”** means a week starting on Monday and ending on Sunday.

## 2. Grant of Licence

2.1 Subject to and conditional upon compliance with the terms and conditions contained herein and in

particular subject to the exclusions and restrictions set out in clauses 3 and 4, MCPSI grants the Licensee a non-exclusive licence to do the following during the Term:

- (a) to reproduce Repertoire Works within Podcasts on servers within the Server Territory for the purpose of transmitting the same to Users (for the User's own private and non-commercial use) by means of the Licensed Services; and
- (b) where the Licensed Services expressly authorise the temporary or permanent reproduction of Repertoire Works within Podcasts on Users' Data Storage Devices, to cause such copies to be made in the Territory for the User's own private and non-commercial use.

For the avoidance of doubt, it is intended that this Agreement licenses all reproductions of Repertoire Works within Podcasts necessary in the ordinary operation of the Licensed Services, but subject always to the terms of this Agreement.

2.2 Subject to and conditional upon compliance with the terms and conditions contained herein and in particular subject to the exclusions and restrictions set out in clauses 3 and 4, IMRO grants the Licensee a non-exclusive licence, during the Term, to make available to the public (as that term is defined in the Act) and to authorise the making available to the public of Repertoire Works within Podcasts within the Territory solely as part of and for the purposes of the provision of the Licensed Services.

2.3 The Licensors will not unreasonably refuse or delay any request by the Licensee to include further services of the Licensee within the scope of this Agreement provided that:

- (a) they are a Music Podcasting Service; and
- (b) the Licensee is, in relation to that service, the Music Service Provider; and
- (c) they are otherwise within the scope and limitations set out in this Agreement.

2.4 The restrictions set out in clauses 4.1, 4.2, and 4.3 shall not apply to a particular Repertoire Work where the owner of the relevant rights in such Repertoire Work has granted permission to the Licensee for the use of that Repertoire Work on the Licensed Services in the manner described under the relevant clause on such terms and conditions (including, if required, the payment of royalties or fees in addition to those specified under this Agreement) as the owner thinks fit.

2.5 The licences granted in clauses 2.1 and 2.2 above shall not apply to any Licensed Service which provides internet or mobile "links" to unlicensed music (whether in the form of recordings or notation, scores, lyrics, etc). The inclusion of such links on a Licensed Service shall constitute a material breach of this Agreement.

### 3. Exceptions and Limitations

3.1 The licences granted under clause 2 of this Agreement are valid only insofar as:

- (a) the Licensed Services are Music Podcasting Services; and
- (b) the Licensee is the Music Service Provider in relation to the Licensed Services.

3.2 For the avoidance of doubt, the licences granted under clause 2 of this Agreement shall not authorise the manufacture or distribution of physical products containing Repertoire Works, such as (without limitation) the ordering of compact discs (or any other type of physical media) via a Music Podcasting Service, but which are distributed by mail.

3.3 For the avoidance of doubt, the licences granted under clause 2 of this Agreement shall not extend to the performing, showing or playing a copy (as the terms are used in the Act) of Repertoire Works, whether as part of the Licensed Services or otherwise.

3.4 Unless (i) the relevant Member has expressly consented to such use being covered under the MCPSI licence granted herein, (ii) the Licensee has entered into an agreement with the relevant Member to this effect and (iii) evidence of such agreement has been provided to the Licensors, the licence granted under clause 2.1 of this Agreement shall not permit the use of Repertoire Work(s) with any advertising or sponsorship where:

- (a) such Repertoire Work(s) are incorporated into such advertising or sponsorship; or
- (b) such Repertoire Work(s) are otherwise presented in such a way that a reasonable person might associate the Repertoire Work(s) with the advertising or sponsorship.

3.5 Unless (i) the relevant Member has expressly consented to such use being covered under the MCPSI licence granted herein, (ii) the Licensee has entered into an agreement with the relevant Member to this effect and (iii) evidence of such agreement has been provided to the Licensors, for the avoidance of doubt (and without prejudice to the generality of clause 3.4), the licences granted under these terms and conditions shall not apply to any Repertoire Work(s) made available for the purpose of (whether in whole or in part):

- (a) directly or indirectly encouraging the User to purchase or obtain goods or services of whatsoever nature (other than music via the Licensed Service); or

- (b) promoting the branding of the Licensee, any affiliate of the Licensee or any third party;

in such a manner that:

- (i) one or more particular Repertoire Works, composers or writers are associated with such promotion; or

- (ii) a reasonable person might assume that there was an association between particular Repertoire Works, composers or writers and such promotion.
- 3.6 The licence granted under clause 2.1 shall not apply to graphic copies (meaning, without limitation, copies of lyrics, notation or scores) of Repertoire Works. For the avoidance of doubt, the licences granted under these terms and conditions shall not apply to any "karaoke" service within a Music Podcasting Service.
- 3.7 The licence granted under clause 2.2 shall only apply to a Repertoire Work made available to the public as part of a Licensed Service where the Licensee has the benefit of a valid licence for or a right to make a reproduction of that particular Repertoire Work and for that particular form of exploitation via the Licensed Service either pursuant to these terms and conditions or otherwise. By way of example only, the licence granted by MCPSI under clause 2.1 does not cover the copying of Repertoire Works in an advertisement (save in certain specified circumstances, see clause 3.4 above). However, a parallel restriction does not apply to the licence granted by IMRO under clause 2.2. The licence granted by IMRO under clause 2.2 would not apply (in the context of this example) unless the Licensee, pursuant to clause 3.4, has the benefit of a right to copy the Repertoire Work for use in that advertisement (and on the Licensed Service(s)).
- 3.8 The licences granted under clause 2 of this Agreement shall not apply to any Repertoire Works reproduced or made available to the public within a Podcast unless:
- each programme comprising each Podcast contains both speech and music with the speech interspersed throughout the programme;
  - such Podcast is provided only in the form of a programme in its entirety and not in the form of individual tracks or portions of such a programme;
  - there can be no guide providing details of the time at which particular tracks appear; and
  - no flags or other markers are inserted within such Podcast which may directly indicate or which may be used to indirectly infer the start and end point of tracks or segments of tracks.
- 3.9 The licences granted under clause 2 of this Agreement shall not apply to any Repertoire Works reproduced or made available to the public within a Podcast if:
- there is any audio-visual material incorporated into the Podcast (unless the Licensor provides its prior written approval in relation to such audio-visual material); or
  - the Podcast includes more than 2 Repertoire Works from a particular album or more than 2 Repertoire Works performed by a particular artist or written by a particular composer without prior written approval of the Licensors ; or
- (c) more than 50% of the Repertoire Works included within such Podcast are written by the same composer or writing partnership or are performed by the same artist without prior written approval of the Licensors, unless the relevant Member has expressly consented thereto.
- 3.10 For the avoidance of doubt, this Agreement grants no licence whatsoever in relation to Repertoire Works which are made available by the Licensee outside of the Licensed Service. However, such other exploitation of Repertoire Works may fall within the scope of other licensing schemes operated by the Licensors, details of which shall be made available to the Licensee on request.
- #### 4. Further Restrictions
- 4.1 Subject to clause 2.5, the licences granted under this Agreement do not cover any Repertoire Works which are dramatico-musical works unless otherwise agreed by the Licensors.
- 4.2 Subject to clause 2.5, the licences granted under this Agreement shall not extend to or permit any adaptation of any Repertoire Work to be copied or made available to the public as part of a Licensed Service unless the relevant Member has consented to such adaptation. By way of example only, this applies to:
- any sampling (meaning the taking of part of the music and/or lyrics of a Repertoire Work and incorporating such part into another Musical Work) or the making available to the public or reproduction in the form of a sample of such part of a Repertoire Work; or
  - using with music lyrics other than those written to be used with the music or authorised for use with the music; or
  - using with lyrics music other than that written to be used with the lyrics or authorised for use with the lyrics.
- However, subject always to clause 4.8 and provided that such alterations do not amount to an adaptation of a Repertoire Work and do not contravene clause 4.3 then this Agreement shall apply in relation to Repertoire Works that have been modified (including music and/or lyrics) for the purpose of satisfying the requirements of the relevant recording.
- 4.3 Subject to clause 2.5, the licences granted under this Agreement shall not extend to:
- the reproduction or making available to the public of any Commercial Work or part thereof in the form of a parody or burlesque of any Commercial Work or of any composer or writer of any Commercial Work or any band or other group of artists which includes any

composer or writer of any Commercial Work; or

(b) the use of any Commercial Work in any context which the Licensee ought reasonably to consider as being likely to be insulting or detrimental to the composer featured on the commercially released sound recording of the music or the relevant Member or Associated Society Member.

4.4 Any additional limitations in relation to the Associated Societies' rights to grant the licences set out in clause 2 of this Agreement which have been notified to the Licensors shall be notified to the Licensee in writing (which may include by email) and shall be binding no less than 10 days following such notice. Where any restriction of a material nature is added, the Licensee shall have the right to terminate this Agreement by giving written notice to the Licensors.

4.5 All rights not specifically granted under this Agreement are hereby reserved.

4.6 This Agreement only covers Repertoire Works. It does not extend to other rights or interests, including (by way of example only), rights in sound recordings, films, dramatic works, performers' rights or rights in performances. The Licensee is required to obtain the appropriate waivers, consents and/or licences from the person(s) owning or controlling rights in relation to sound recordings containing Repertoire Works or performers of that Repertoire Work.

4.7 It is the responsibility of the Licensee to obtain all necessary licences in relation to any Musical Work which is not, or to the extent that it is not, a Repertoire Work, and no licence is granted under this Agreement in relation thereto.

4.8 Nothing in this Agreement affects the moral rights of authors of Repertoire Works whether subsisting within or outside Ireland or any other territory.

## 5. Payment and Accounting

5.1 In consideration of the licences and authorisations granted under this Agreement, the Licensee shall pay to the Licensors:

(a) the Quarterly Advance; and

(b) subject to clause 5.2, the Royalty Fee.

5.2 The Quarterly Advance is recoupable against the Royalty Fee. If any part of the Quarterly Advance remains unrecouped at the end of a Quarter, such unrecouped amount may be carried over to subsequent quarters, but for the avoidance of doubt, shall not (except as set out in clause 5.3 below) have the effect of reducing any subsequent Quarterly Advance. If any part remains unrecouped upon termination or expiry of the Agreement, the Licensors shall return such part to the Licensee.

5.3 The Quarterly Advance shall be reviewed at the end of each calendar year. It may also be reviewed during a calendar year if the royalties calculated for

any particular Quarter under schedule 2 differ from the Quarterly Advance by 20% or more.

5.4 Where, in relation to any particular Quarter, the Licensee fails to provide by the required date the information required under the Agreement to allow the calculation referred to in clause 5.1(b), then the Licensors shall be entitled to fix the Royalty Fee based on (a) the Royalty Fees payable in previous Quarters and (b) any other relevant factors which could reasonably lead the Licensors to believe that the Royalty Fees payable would be materially different to those paid or payable in previous Quarters.

5.5 The Quarterly Advance shall be payable by direct debit on the first day of each Quarter. Where the Agreement begins (and/or a Licensed Service comes into operation) within a Quarter, the first Quarterly Advance payment shall be pro-rated (according to the Commencement Date) and shall be payable upon the later of signature of this Agreement and the date on which the first Licensed Service is made available to Users for the first time.

5.6 Within 15 working days of the end of each Quarter, the Licensee shall provide to the Licensors a fully and accurately completed Quarterly Royalty Statement (at the address notified by the Licensors to the Licensee)..

5.7 MCPSI shall, on behalf of the Licensors, each of the Members and, subject to clause 4.4, the Associated Societies, raise an invoice for the due amount, and the Licensee shall pay such invoice by electronic bank transfer (or, if agreed by the Licensee, direct debit) within 21 days of the invoice date.

5.8 All licence fees and payments referred to in this Agreement are subject to VAT or other equivalent sales tax. The Licensee shall pay to the Licensors VAT or other equivalent sales tax (if applicable) at the rate or rates from time to time in force on any sums payable under this Agreement.

5.9 Except as expressly set out in this Agreement, no deduction in respect of any tax, or any other deduction or set-off of whatsoever nature, shall be made in calculating or paying any sum due under this Agreement.

5.10 Notwithstanding the provisions of this clause 5, the Licensors confirm and warrant that MCPSI is authorised to receive all payments under this Agreement as agent on behalf of the Licensors, each of the Members and, subject to clause 4.4, the Associated Societies.

5.11 Without prejudice to any other right or remedy of the Licensors, and without imposing an obligation to accept late payment, where any fees payable under this Agreement are not paid by the due date (or the date on which such fees should ordinarily have been paid in circumstances where the Licensors have been unable to submit an invoice) due to default of the Licensee, the Licensee shall (if required by the Licensors) pay interest on such late payment calculated on a daily basis at an annual

rate of 3% over the prime overdraft rate, current from time to time, of the Bank of Ireland payable from the date on which the payment should have been made to the date on which the payment was made.

5.12 All payments made under this Agreement shall be in Euro unless otherwise agreed by the parties in writing. Where it is necessary to convert an amount payable to Euro from another currency, the exchange rate used shall be the Irish Times closing mid market rate on the last working day of the Quarter to which the payment relates. The Licensee shall pay all bank charges on transfers of sums payable by the Licensee to the Licensors.

5.13 In respect of Music Podcasting Services where a significant proportion of Musical Works accessed by Users are either no longer in copyright in the relevant part of the Territory or are otherwise not Repertoire Works (by way of example, services specialising in classical music), the Licensors shall agree an appropriate deduction to the Gross Revenue and Minimum Royalties to apply as from the Commencement Date. This deduction shall be reviewed every six Months.

5.14 The provisions of paragraph 3.4 of Schedule 2 shall apply if any dispute arises in relation to the application of the provisions of clauses 5.13 above or if agreement cannot be reached between the parties in relation to the appropriate adjustment or deduction to be made pursuant to those provisions.

## 6. Supply of Information

6.1 In relation to any and all Repertoire Works reproduced and made available to the public under this Agreement via all Licensed Services, the Licensee will deliver the Music Usage Information to the Licensors or to the Licensors' duly authorised agent (details of which will be provided to the Licensee) in the Electronic Reporting Format quarterly by the Reporting Date.

6.2 The Licensee must also supply the Licensors with any further information or documentation in its possession, power, custody or control (and use its reasonable endeavours to supply the Licensors with any further information or documentation not in its possession, power, custody or control) reasonably requested by the Licensors at any time, in order to enable the Licensors to verify the Repertoire Work(s) which have been reproduced or distributed via all Licensed Services.

6.3 To assist the Licensors in developing a new scheme to apply to Music Podcasting Services following the expiry of this scheme, if the Licensors so request, the Licensee agrees to share with the Licensors on a confidential basis (and otherwise in a manner and at a time to be agreed between the parties) generic data and information collected during the Term, including, but not limited to, the following:

- (a) a general description of Podcasts (for example, a download of a previously broadcast radio programme or new, customised content);

- (b) the period during which each Podcast was on offer for;
- (c) how each Podcast was promoted;
- (d) the number of downloads per week for the time during which each Podcast was offered;
- (e) the objective(s) of offering each Podcast (for example, brand building; new opportunities to connect with core market; attracting new market/listeners); and
- (f) a description of the 'market' reaction to each Podcast.

6.4 Where any or all of the Licensed Services are accessible by Users only on payment of subscription or other similar payment (or access is otherwise limited or controlled in some way), the Licensee shall, upon request of the Licensors, use reasonable endeavours to ensure that such Licensed Services are at all times accessible by the Licensors free of charge for the purposes of the Licensors verifying that the Licensee is acting in accordance with this Agreement. For the avoidance of doubt, the Licensee shall not be required to provide free access to downloads or to provide free access to a mobile phone network or internet access.

6.5 The Licensee acknowledges that the Licensors have a responsibility to maximise the efficiency of their reporting to their Members and the Associated Societies. Therefore, if the Licensors wish to make any reasonable upgrade or alteration of whatsoever nature to the Electronic Reporting Format or the Quarterly Royalty Statement format during the Term, the Licensee agrees to use its reasonable endeavours to implement the changes required as soon as is reasonably practicable, PROVIDED THAT the Licensors shall not request that the Licensee implements the change in less than six Months from the making of the request, and in each case of a change the following procedures shall apply:

- (a) the Licensors shall give full details thereof in writing to the Licensee;
- (b) the Licensee will respond in writing within 4 Weeks of receipt of the request, stating the date by which it commits to comply with the change and the Licensors shall provide full assistance to the Licensee in order to assist the Licensee in complying with the change; and

the parties will then finalise the details and undertake tests to ensure that the change operates satisfactorily within the terms of this Agreement, satisfactory operation of which will be deemed acceptance of the change and the definition of Electronic Reporting Format, Music Usage Information and/or the Quarterly Royalty Statement will be amended or replaced accordingly. For the purpose of this clause, in

determining what change may be reasonable, regard shall be had to the DDEX project.

- 6.6 Without prejudice to any right in law that the Licensors may have to obtain such information, the Licensee shall not be obliged to provide to the Licensors any information which identifies Users or which otherwise constitutes "personal data" as defined in the Data Protection Acts 1988-2003. For the avoidance of doubt, the Licensee must still provide all required Music Usage Information (or other information to be provided under this Agreement), but is entitled to remove any element of it which reveals the identity of Users or otherwise causes it to include or constitute "personal data".

## 7. Late Reporting

- 7.1 The following provision applies where the Licensee has:
- (a) failed to deliver prior to the required date Music Usage Information for the Licensed Service; or
  - (b) delivered such Music Usage Information prior to the required date, but it contains any omission or error of whatsoever nature (by way of example only, Repertoire Works having been omitted there from or incorrectly or misleadingly named, or the duration of any Repertoire Works having been under-reported) which is material and the Licensee has failed to give notice in writing to the Licensors correcting the omission or error by the date upon which such reporting should have been provided.
- 7.2 In such circumstances (and without prejudice to any other rights which either or both Licensors may have against the Licensee) if one or both of the Licensors has distributed some (or all) royalties received (excluding any commission) to Members and/or Associated Societies based on the usage data supplied, but, as a result of clause 7.1(a) or (b) applying, the royalties distributed do not accurately or fairly represent that which each of the Members and/or Associated Societies should have received (when considering the true usage of Repertoire Works), then the Licensee shall pay the fees set out in clauses 7.3 and 7.4 (in addition to those set out in clause 5).
- 7.3 Where clause 7.2 applies, separately in relation to each relevant Repertoire Work either omitted from the relevant Music Usage Information or as regards which there was a material omission or error of whatsoever nature or in relation to which the relevant Music Usage Information was not delivered, the additional fees shall be calculated at the rate equivalent to that which has been or will be paid by MCPSI and/or IMRO (as applicable) to their members (or associated societies) in relation to the Music Usage Information which was submitted prior to the required date.
- 7.4 Where clause 7.2 applies, the Licensee will also pay interest on the additional fees as referred to in clause 7.3 above computed in accordance with clause 5.11 and calculated from the date on which MCPSI and/or IMRO (as applicable) first made a distribution to their members (or associated

societies) in relation to the relevant period to the date on which the Music Usage Information was received by the Licensors or the date on which the Licensors received written notice of the relevant error, as the case may be.

- 7.5 The provisions of this clause apply notwithstanding any other provision of this Agreement, but are without prejudice to any other right which MCPSI and IMRO have in relation to any failure to submit Music Usage Information fully or accurately completed within the time stipulated in clause 6.1.

## 8. Credits and Notices

- 8.1 The Licensee shall include on each of the Licensed Services:
- (a) the logos of IMRO and MCPSI; and
  - (b) where reasonably practicable, the name of the composer and publisher of the Repertoire Works provided via the Licensed Services; and
  - (c) a notice explaining that use of the musical works is subject to restrictions, and that a summary of these restrictions may be obtained by accessing the Licensors' website through the link referred to above.

Approval of the Licensors shall be deemed to be given to the positioning of the above credits and notices within the terms and conditions of the Licensed Service(s) where it is not reasonably practical to position such information elsewhere.

## 9. Auditing

- 9.1 The Licensee shall keep and make available for inspection upon reasonable notice (and shall procure that each relevant party keeps and makes available for inspection upon reasonable notice), both during and for twelve Months after termination of this Agreement, proper, detailed books and records relating to (a) use of all Musical Works and (b) any income or other consideration received by or on behalf of the Licensee in relation to or arising from the Licensed Services, together with any supporting documentation relating thereto covering the period up to six years prior to the date of notification of audit.
- 9.2 For the purposes of this clause 9, the Licensee shall allow upon reasonable notice (and shall procure that each relevant party shall allow) access to its premises to inspect relevant accounting records, but not more than once per annum. The duly authorised representatives (who shall be external qualified accountants or auditors unless otherwise agreed between the parties) of the Licensors shall have such access to the Licensee's premises and shall be entitled to inspect, make extracts and take copies of any of the information and/or documentation available and to carry out such work as is, in their reasonable opinion, considered necessary to verify compliance with this Agreement.

- 9.3 If tests under any audit and verification process indicate under-payment of the correct Royalty Fee during the period under audit, then, without prejudice to the Licensors' other rights under this Agreement, the Licensee shall pay the amount of the underpayment plus interest based on the period from which the correct fee should have been paid to the Licensors to the date when it was actually paid (at the rate set out in clause 5.11).
- 9.4 If any audit and verification process discloses (a) under-payment of more than 7.5% of the correct Royalty Fee during the period under audit and/or (b) failures to report correctly (so as to affect a distribution by the Licensors to their Members) amounting to at least 7.5% of the music usage during the period under audit, then, without prejudice to the Licensors' other rights under this Agreement, the Licensee shall pay, in addition to the payment referred to in clause 7.3, the Licensors' reasonable costs of such audit and verification within 28 days of receipt of the Licensors' VAT invoice therefor.
- 9.5 The Licensors shall not (and shall procure that their representatives shall not), without the Licensee's written consent, disclose to any third party any confidential information of the Licensee (so long as it remains confidential) received in the course of an audit carried out under this clause 9, save that such confidential information may be disclosed to the Licensors' directors, board sub-committee members officers, employees and professional advisors (solely where such persons are under a duty of confidentiality in relation to information so received and the Licensors shall be liable to the Licensee in respect of any breach of such confidentiality obligation) solely for purposes connected with this Agreement.
- 9.6 For the avoidance of doubt, books, records and accounting records as referred to in clauses 9.1 and 9.2 above shall include data, information and records held on computers.
- 9.7 The Licensee shall, if requested by the Licensors, provide a statement from its auditors (but not more than once per year) confirming that the financial information submitted by the Licensee for the relevant requested period is in accordance with the actual Gross Revenue (as defined under this agreement) for that period.
- 10. Security and Encryption**
- 10.1 Unless agreed otherwise, the Licensee will utilise or require the utilisation of an industry security standard which is developed and is available for use in the protection of Repertoire Works. Until such time, the Licensee must use its reasonable endeavours to prevent unauthorised copying and/or the unauthorised issuing of copies of Repertoire Works by whatever technical means are practicable. Upon request the Licensee will inform the Licensors concerning its progress in relation to fulfilling this obligation.
- 10.2 Save as may be permitted by law, the Licensee agrees it shall not (and shall procure that any Relevant Party shall not) attempt to:
- remove or alter any rights management or identifier information that may be associated with any Repertoire Works; or
  - circumvent any technical measures associated with any Repertoire Work which are designed to prevent or restrict the unauthorised use of any Repertoire Work.
- 11. Termination and Expiry**
- 11.1 This Agreement shall expire on 31st December 2024 unless terminated earlier by written agreement or in accordance with the terms of this clause 10.
- 11.2 This Agreement may be terminated by the Licensee, by giving not less than three Months written notice to the Licensors or upon written notice in circumstances where the Licensee is ceasing to engage in activities covered by this Agreement.
- 11.3 Each party shall have the right to terminate this Agreement by notice forthwith where the other party:
- commits a material breach of this Agreement which is capable of remedy and fails to remedy such breach within 14 clear days after receipt of notice of such breach; or
  - commits a material breach of this Agreement which is not capable of remedy,
- and, for the avoidance of doubt, any breach which consists of a failure by either party to perform an obligation under this Agreement within any period required or by any date specified under this Agreement shall be deemed to be capable of remedy if such obligation is performed by such party within the 14 day cure period specified in clause 11.3(a) above.
- 11.4 The Licensors shall have the right to terminate this Agreement by notice forthwith if the Licensee:
- is dissolved (other than pursuant to a consolidation, amalgamation or merger);
  - becomes insolvent or is unable to pay its debts as they become due (as that term is defined in as that term is defined in Companies Acts 1963 - 2007) or fails or admits in writing its inability generally to pay its debts as they become due;
  - makes a general assignment, arrangement or composition with or for the benefit of its creditors;
  - institutes or has instituted against it a proceeding seeking a judgment of insolvency or bankruptcy or any other relief under any bankruptcy or insolvency law or other similar law affecting creditors' rights, or a petition is

presented for its winding-up or liquidation, and, in the case of any such proceeding or petition instituted or presented against it, such proceeding or petition:

- (i) results in a judgment of insolvency or bankruptcy or the entry of an order for relief or the making of an order for its administration, winding-up or liquidation; or
  - (ii) is not dismissed, discharged, stayed or restrained in the case of a winding-up petition within 14 days or in the case of an administration petition within 2 days, of the institution or presentation thereof;
- (e) has a resolution passed for its winding-up, official management or liquidation (other than pursuant to a consolidation, amalgamation or merger);
- (f) seeks or becomes subject to the appointment of an administrator, provisional liquidator, conservator, receiver, trustee, custodian or other similar official for it or for all or substantially all its assets;
- (g) has a secured party take possession of all or substantially all its assets or has a distress, execution, attachment, sequestration or other legal process levied, enforced or sued on or against all or substantially all its assets and such secured party maintains possession, or any such process is not dismissed, discharged, stayed or restrained, in each case within 30 days thereafter; or
- (h) causes or is subject to any event with respect to it which, under the applicable laws of any jurisdiction, has an analogous effect to any of the events specified in clauses (a) to (g) (inclusive).

11.5 The licences granted under clause 2 of this Agreement are so granted on the basis of the representations made by the Licensee in the application form.

11.6 Termination of this Agreement for whatever reason shall be without prejudice to any rights which have already accrued to the parties under this Agreement.

## 12. Effect of Termination

12.1 Upon termination of this Agreement all licences granted under this Agreement shall terminate and the Licensee shall immediately cease to be licensed by the Licensors for the reproduction or making available to the public of Repertoire Works via the Licensed Services. Termination shall be without prejudice to the ability of Users to retain a copy of a Repertoire Work received by them pursuant to the Licensed Service where such Licensed Service authorises the retention of copies.

12.2 Clauses 5, 6, 7, 9, 12, 15 and 16 shall survive the termination of this Agreement, but only in relation to the Licensee's activities during the Term.

## 13. No Assignment

13.1 Subject to clause 13.2, the licences granted under this Agreement are personal to the Licensee and the Licensee may not assign, sub-license or otherwise transfer any or all of its rights or obligations under this Agreement without the written agreement of both MCPSI and IMRO..

13.2 Subject always to the other provisions of this Agreement, the Licensee shall be permitted to use the services of a third party in operating the Licensed Services, provided that:

- (a) the Licensee retains complete control and direction over the provision of the Licensed Services to Users; and
- (b) the Licensors are able to audit such third party in accordance with clause 9.

13.3 The Licensee shall include the following provisions in its terms and conditions for the supply of the Licensed Services to Users:

- (a) that any Repertoire Works made available to Users may only be copied as permitted under this Agreement or by applicable law; and
- (b) that, save as may be permitted by law, no attempt shall be made by Users to:
  - (i) remove or alter any rights management or identifier information that may be associated with any Repertoire Works; or
  - (ii) circumvent any technical measures associated with any Repertoire Work which are designed to prevent or restrict the unauthorised use of any Repertoire Work.

13.4 The Licensee shall, upon request by either Licensor, supply such Licensor forthwith with a copy of the Licensee's standard terms and conditions applying to the provision of any or all of the Licensed Services.

## 14. Controlled Composition Agreements

Where any person, firm or company is or becomes a member of either of the Licensors or an Associated Society and that party itself or that party's predecessor in title or grantor has a current contract with the Licensee or the Licensee's predecessor in title or grantor:

- (a) to the extent that such contract would otherwise apply in relation to the grant of any or all of the licences referred to in this Agreement and/or the terms and conditions on which such licences are granted, the terms and conditions of this Agreement shall during the subsistence of this Agreement replace the terms and conditions of that contract; and
- (b) upon the written request of the Licensee the relevant Licensor will provide the Licensee with evidence that the relevant Member has become a Member and has given the relevant



Licensors or the relevant Associated Society authority to bind the Member as regards this Agreement.

This clause does not prevent the Licensee from obtaining a licence only in relation to the rights referred to in clause 2.1 from the relevant party owning or controlling such rights where such licence is validly obtained whether before or after the Commencement Date but other than as a result of a contract with an individual composer or recording group.

For the avoidance of doubt, where the Licensee is exploiting the relevant rights outside the territory, and has in relation to such exploitation a valid licence from the Associated Society entitled to grant that licence in relation to the relevant territory or territories, this clause 15 does not operate so as to override the terms of that licence.

## 15. Notices

- 15.1 Except where expressly stated otherwise, any notice or other written communication given under or in connection with this Agreement shall only be effective if it is in writing. Faxes and e-mails are permitted. In the absence of any legitimate electronic signature system, either party shall be permitted to require the confirmation in writing (signed by an authorised signatory) of any notice originally sent by email.
- 15.2 The address for service of any party shall be its registered office marked for the attention of the Chief Executive or Managing Director, or, if any other address or addressee for service has previously been notified to the server, to the address so notified. A single notice served on or sent to either Licensor shall be treated as validly served on both Licensors.
- 15.3 Any such notice or other written communication shall be deemed to have been served:
  - (a) if personally delivered, at the time of delivery;
  - (b) if posted, at the expiry of two business days or in the case of airmail four business days after it was posted;
  - (c) if sent by facsimile message or e-mail, at the time of receipt of transmission (if received during normal business hours that is 09.00 to 17.00 local time) in the place to which it was sent or (if not received during such normal

business hours) at the beginning of the next business day at the place to which it was sent.

- 15.4 In proving service of a notice it shall be sufficient proof that personal delivery was made, or that such notice or other written communication was properly addressed stamped and posted or in the case of a facsimile message or e-mail that an activity or other report from the sender's facsimile machine or computer can be produced in respect of the notice or other written communication, in the case of a fax, showing the recipient's facsimile number and the number of pages transmitted.

## 16. Miscellaneous

- 16.1 No delay or omission in exercising any right or remedy hereunder shall operate as a waiver thereof or of any other right or remedy and no single or partial exercise thereof shall preclude any other or further exercise thereof or the exercise of any other rights or remedies. No waiver shall be binding or effectual for any purpose unless expressed in writing and signed by the party giving it and any such waiver shall be effective only in the specific instance and for the purpose given.
- 16.2 This Agreement sets forth the entire agreement of the parties in relation to the subject matter hereof and each of the parties hereto acknowledges that it has not entered into this Agreement in reliance on any representation or term not contained in this Agreement.
- 16.3 The headings to the clauses in this Agreement are included for ease of reference only and are not part of this Agreement and are not to be taken into account in its construction.
- 16.4 The parties shall (and shall procure that any other necessary party within its control shall) execute all such documents and do all such acts and things as may be reasonably be required on or subsequent to completion of this Agreement for securing each of the obligations of the respective parties under this Agreement.
- 16.5 If this Agreement creates any rights which would in the absence of this provision be enforceable by any person not a party to this Agreement, such rights shall not be enforceable.
- 16.6 This Agreement shall be construed according to the laws of Ireland and the parties agree to submit to the jurisdiction of the Irish Courts.

## SCHEDULE 1 Royalty Fee

### 1. Definitions

**“Applicable Revenue”** means the Gross Revenue less VAT (or other equivalent sales tax, as applicable).

**“Minimum Royalties”** means the applicable minima set out in paragraph 2.1(b) below.

### 2. Royalty Fee

2.1 The Royalty Fee shall be the higher of:

- (a) 8% of the Applicable Revenue; and
- (b) €0.0026 in respect of each Musical Work (or part thereof, subject to 2.2 below) included within a Podcast in respect of each occasion that such Podcast is downloaded by a User.

2.2 For the avoidance of doubt, the calculation leading to the Royalty Fee for a particular Podcast, being either (a) or (b) above shall be carried out individually in respect of each Podcast to each User and then the Royalty Fees, calculated on that basis, for all Podcasts to all Users shall be added together in order to calculate the full Royalty Fees due. For the purposes of the foregoing calculation, where there is any Gross Revenue arising which is not attributable to a particular Podcast (for example, revenue arising from advertising or sponsorship etc), this shall be apportioned equally between all Podcasts.

### 3. Bundling

3.1 Where a Music Podcasting Service (for the purposes of this clause “Service A”) is provided to Users in conjunction with a service which is not a Music Podcasting Service (for the purpose of this clause “Service B”), then the price deemed to be payable by Users (“the User Price”) for the Music Podcasting Service (for the purpose of calculating Gross Revenue) shall be calculated in accordance with this paragraph 3.

3.2 Where there are separate published prices for Service A and Service B when available alone, then the User Price shall be the proportion of the

bundled price represented by the relative standalone prices for Service A and Service B.

3.3 Where there are no separate published prices for Service A and Service B, then the User Price shall be deemed to be the proportion of the bundled price represented by the relative standalone prices for comparable Irish services for Service A and Service B. If there is more than one comparable service, then the average shall be used.

3.4 If there are no comparable Irish standalone services for Service A and Service B, then the applicable Minimum Royalties shall be payable.

3.5 For the avoidance of doubt, where the User Price is set according to either of paragraphs 3.2 and 3.3 above, the royalty payable shall be the higher of the applicable royalty rate applied to the User Price and the applicable Minimum Royalty.

3.6 The provisions of paragraph 3.4 of Schedule 2 shall apply if any dispute arises in relation to the application of the provisions of this paragraph 3 of Schedule 1 as to whether and if so at what level the User Price shall be set pursuant to paragraphs 3.2 and 3.3 above.

### 4. Promotional Use

For the avoidance of doubt

(a) where the Licensee provides to Users Musical Works for free, then the Royalty Fee shall still be calculated in accordance with the applicable Minimum Royalties;

(b) where the Licensee sells credits to access music on the Licensed Service at a discount to a third party so that such third party can supply credits to Users that can be redeemed on the Licensed Service, then such of those credits as are redeemed shall be deemed to attract the same Applicable Revenue (for the purposes of 2.1(a) above) as if the Licensed Service had been supplied directly to the User by the Licensee at the undiscounted price charged at that time by the Licensee for such Licensed Service.

## SCHEDULE 2 Gross Revenue

### 1. Definitions

“**Gross Revenue**” means, subject to the provisions of this Schedule:

- (a) all revenue received (or receivable) by the Licensee from Users in consideration for the provision of the Licensed Services; and
- (b) all revenue, including by way of sponsorship and commissions, received (or receivable) by the Licensee as a result of the inclusion of third party advertising "in-download" as part of the Licensed Service, being advertising placed immediately at the start, end or during the actual delivery (by way of downloading) of a Podcast to a User; and
- (c) all revenue, including by way of sponsorship and commissions, received (or receivable) by the Licensee as a result of the placement of third party advertising on a Relevant Page (as defined below) of the Licensed Service (and including any page which directly follows such Relevant Page leading up to and including the downloading of the offering);

and in each of the above cases such revenue shall, for the avoidance of doubt, include any such revenue whether received or receivable by the Licensee or any associate, affiliate, agent or representative of such party.

Subject to the remainder of this schedule 2, there shall be no other deduction or set-off from the above revenues other than refunds to Users for services that they were unable to use due to technical faults in the Licensed Services.

“**Relevant Page**” means a page:

- (a) from which Licensed Services are “actually offered” to Users. A Licensed Service is “actually offered” to Users from a page if a Podcast is enabled or made directly available from that Licensed Service to the User from that page (in most cases this will be where such Podcasts can be purchased by the User or their download otherwise takes place); but only
- (b) where such offering forms all or the predominant part of that page, being for the purposes of this Agreement where the offering comprises 75% or more of the space on that page excluding space occupied by any advertising. For the purposes of performing the foregoing calculation, the "offering" shall include any content which directly relates to the actual offering of the Licensed Service pursuant to sub-paragraph (a) above (by way of example, but without limitation, an image of the artist or artwork closely associated with the offering, reviews of the offering, credits, and music player controls).

### 2. General

2.1 For the avoidance of doubt, the definition of Gross Revenue above shall be applied in conjunction with the provisions on bundling set out in paragraph 3 of schedule 1. The Licensors confirm that no revenue which is included in Gross Revenue under this Agreement shall form any part of the “revenue base” under any other licence or licensing scheme operated by the Licensors (or either of them) which grants all or some of the rights set out in clauses 2.1 and 2.2 of the main body of this Agreement (albeit in relation to a service which is not a Licensed Service hereunder).

2.1 For the further avoidance of doubt, revenue which relates solely to services other than the Licensed Service shall not be included in the Gross Revenue. By way of example, this includes:

- (a) revenue derived from non-music voice, content and text services;
- (b) revenue derived from music or music-related services which is/are not a Music Podcasting Service (including without limitation any ringtones services);
- (c) revenue derived from non-music products and services (including search services) supplied by the Licensee.

2.3 For the further avoidance of doubt, Gross Revenue shall not be reduced by credit card commissions or similar payment process charges.

### 3. Advertising and Sponsorship Revenue

3.1 Gross Revenue obtained in the form of advertising or sponsorship revenue shall be reduced by 5% to reflect the costs of obtaining it.

3.2 For the avoidance of doubt, advertising revenue referred to in sub-paragraph (b) of the definition of Gross Revenue above shall not include revenue arising from sponsored searches or click-through commissions arising from such searches.

3.3 The provisions of paragraph 3.4 below shall apply if a dispute (a “Dispute”) arises in relation to the application of the provisions of Schedule 2 as to what revenue is included within the definition of Gross Revenue.3.4 (a) The provisions of this paragraph shall apply if a dispute (a “Dispute”) arises in relation to the application of the provisions of this Schedule 1 as to what revenue is included within the definition of Gross Revenue.

- (b) Provided that the Licensors and the Licensee shall have held substantive negotiations in good faith regarding the subject matter of the Dispute over a period of at least 21 days from

the date on which the Licensors notify the Licensee or the Licensee notifies the Licensor (as the case may be) in writing of the existence of such Dispute, the Licensors or the Licensee shall then be entitled by notice in writing from the Licensors to the Licensee or by Licensee to the Licensors to refer the Dispute for determination to an independent arbitrator acting as an expert. The identity of such expert shall either be agreed or, in the absence of such agreement within 7 days of the written notice of referral, shall be determined by the President for the time being of the Institute of Chartered Accountants in Ireland, and shall be an independent chartered accountant, unless the Licensors and the Licensee agree that another type of expert would be more suitable to determine such Dispute. The Licensors and the Licensee will seek to agree the procedure for the conduct of any expert determination. If such agreement is not reached within 7 days of the appointment of the expert, the expert shall have power to set the procedure for the expert determination. The expert shall make his determination as soon as reasonably practicable. The expert shall have power to award costs in the expert's determination, unless the Licensors and the Licensee agree otherwise. The decision of the expert is final and binds the parties to the Dispute unless there is manifest error, wilful default or fraud. For the avoidance of doubt, it is hereby confirmed that the expert shall have no jurisdiction to amend any term of the Agreement.

- 3.5 For the purposes of paragraph (c) of the definition of "Gross Revenue" above, where Music Podcasting Services are offered from a page together with other content licensable by MCPSI and/or IMRO to the Licensee (for example, under the Licensors' Joint Ringtone Licence scheme), the parties will enter good faith discussions to determine, in respect of such content, how the royalty rate should be determined in relation to revenue gained from advertising and sponsorship on that page.

#### **4. Vouchers**

- 4.1 This paragraph 4 applies only to a Licensee which runs a voucher scheme where each issued voucher ("the Voucher"):
- (a) is issued in conjunction with a festival or other musical event, and the voucher contains no branding other than that of the Licensee, the band/artist performing at the festival or other musical event, and/or the festival or other musical event; or
  - (b) does not refer to any specific artist(s), band(s) or Musical Work(s).

Repertoire Works provided via a Voucher scheme which is outside this paragraph 4.1 are not licensed under this Agreement and a separate licence for

premium usage of this type must be sought from the Licensors.

- 4.2 The price of each Voucher, calculated in accordance with paragraph 4.3, below shall be included in Gross Revenue if and to the extent that it is redeemed by a User or Users.
- 4.3 The price of each Voucher shall be calculated as follows:
  - (a) Where the Voucher does not contain any branding or no branding other than (i) that of the Licensee for the Licensed Service, (ii) that of a third party ordinarily engaged in the sale of vouchers to Users or (iii) as permitted under paragraph 4.1(a) above, the price shall be the price charged to each User.
  - (b) Except as set out in (a) above, where the Voucher contains branding of a third party (which includes for the purposes of this paragraph 4.3(b) an entity in the same corporate group as the Licensee) and/or is distributed as part of a promotion by a third party, the price shall be deemed to be the full usual retail price charged by the Licensee for the Music Podcasting Service to which the Voucher relates.

**SCHEDULE 3**

Music Usage Information

IMRO MCPSI Reporting Format

To be agreed with Licensee

**IMRO COPYRIGHT LICENCE  
FOR RINGTONES/RINGBACKS**

**BETWEEN**

(1) **IRISH MUSIC RIGHTS ORGANISATION CLG**

and

## Contents

	<b>Page No.</b>
1. <b>Interpretation</b> .....	2
2. <b>Licence</b> .....	5
3. <b>Warranty</b> .....	7
4. <b>Licence Payments</b> .....	7
5. <b>Late payment and Late reporting</b> .....	8
6. <b>Information and inspection</b> .....	9
7. <b>Termination</b> .....	10
8. <b>Information provided by Licensee</b> .....	10
9. <b>Severability</b> .....	10
10. <b>Copyright Notices</b> .....	11
11. <b>Notices under the Agreement</b> .....	11
12. <b>No partnership, Agency Etc.</b> .....	11
13. <b>Entire Agreement</b> .....	11
14. <b>Confidentiality</b> .....	11
15. <b>Indemnity</b> .....	12
16. <b>Miscellaneous</b> .....	13
Schedule 1 .....	15
Schedule 2 .....	16
Schedule 3 .....	17





- “IMRO Member”** shall mean any person, firm or company who or which from time to time, pursuant to the Articles of Association of IMRO has been admitted either before or during the term of this Agreement as a member of IMRO and has assigned the Making Available Right in their Musical Works to IMRO, provided that, those admitted after the Commencement Date shall only be regarded as a member for the purposes of this agreement with effect from the date of their assignment of the Making Available Right to IMRO and provided that any person, firm or company ceases to be a member for the purposes of this Agreement in the event that they discontinue their membership and secure the reassignment of their Making Available Right from IMRO.
- “Interest”** shall mean interest charged at a rate of 3 per cent over the prime overdraft rate current from time to time of the Governor and Company of Bank of Ireland
- “Licensed Repertoire”** shall mean all or any Musical Works in which the right to licence the Making Available Right is vested in IMRO in the Territory provided that if one or more of those who own the Making Available Right in a Musical Work has not assigned this right to IMRO, or otherwise authorised IMRO (through an Associated Society) to licence this Right, the expression “Licensed Repertoire” shall only apply to such interest in the Musical Work as is owned or licensed to IMRO.
- “Licensed Repertoire Work”** shall mean a Musical Work from the Licensed Repertoire.
- “Licensed Tones”** shall mean Ringtones and Ringbacktones which incorporate no more than 45 seconds of a Musical Work from the Licensed Repertoire.
- “Licensed Tone Revenue”** shall mean all fees paid (ex VAT) by the Users for the Making Available of Licensed Tones either by way of Preview or download for use by User, or otherwise.
- “Making Available Right”** shall mean:
- (a) in respect of IMRO Members’ Musical Works, the copyright assigned by IMRO Members to IMRO and set out in section 40(1)(a) of the Act, namely the right to make available to the public copies of a work, by wire or wireless means, in such a way that members of the public may access the work from a place and at a time chosen by them (including the making available of copies of works through the Internet), insofar as the

above mentioned right exists under the law in force from time to time relating to copyright in the State; together with such corresponding or similar rights as subsist under the laws relating to copyright in the State from time to time; and

- (b) in respect of Associated Societies' Musical Works the copyright IMRO is authorised to licence by Associated Societies in the Territory in respect of these societies' repertoires.

and the terms "Making Available" and "Made Available" shall be interpreted accordingly in this Agreement.

**"Minimum Quarterly Payment"**

shall mean the amount specified at paragraph no 1 of Schedule 3 to be paid, if applicable, pursuant to Clause 4.1 of this Agreement, and in the manner provided for in Clause 4 hereof generally

**"Minimum Royalty per Licensed Tone Supplied"**

shall mean the amount specified at paragraph 3 of Schedule 3 as the minimum amount payable per each Licensed Tone Supplied

**"Musical Work"**

means any work consisting of music and any lyrics or words written to be used with the music (if applicable). It includes any part of such a work.

**"Mobile Phone"**

shall include all portable devices, one of whose functions is communicating with other such portable devices through a telecommunications system or with fixed line telecommunications systems.

**"Permitted Excerpts"**

shall mean an excerpt from a Dramatico-Musical Work the total duration of which does not exceed 25 minutes or 25 per cent of the total length of the work whichever shall be the shorter and which excerpt:

- (a) is not a "potted" version of the work; or  
(b) is not or does not cover a complete act of the work.

**"Preview"**

shall mean a Ringtone which is streamed to Users to listen to only prior to purchase but which may not be downloaded by the User.

**"Quarterly Statement"**

shall mean the statement from the Licensee containing the information set out in Schedules 1 and 2 to this Agreement. IMRO reserves the right to alter the form and required content

of this statement, upon the provision of a month's notice to the Licensee.

**“Ringtone”** shall mean a short audio recording the primary purpose of which is to notify incoming calls or messages on Mobile Phones.

**“Ringbacktone”** shall mean a short audio recording played to the dialler of a telephone call while the telephone number they have dialled is ringing.

**“Royalty”** shall mean the amount calculated in accordance with paragraph no. 4 of Schedule 3 and to be paid, if applicable, pursuant to Clause 4.1 of this Agreement and in the manner provided for in Clause 4 generally

**“Royalty Rate”** shall mean the percentage rate specified in Schedule 3.

**“Supply”** shall mean the downloading of Licensed Tones for use by Users, whether such downloading is done from networks, websites or other facilities provided by Licensee or under this Licence by any affiliate or associate, agent or representative of the Licensee or by an intermediary through whom Licensed Tones are Made Available to Users by the Licensee

**“Territory”** shall mean the Republic of Ireland.

**“User”** shall mean any person who Previews or downloads a Licensed Tone, directly or indirectly from the Licensee, for their Mobile Phone.

**“VAT”** shall mean value added tax which is chargeable on the supply of goods and services within the Territory in accordance with European and Irish tax law, including the Value Added Tax Act 1972 as amended and the EU VAT Directives issued from time to time.

1.2 Headings to clauses in this Agreement are included for the purposes of ease of reference only and shall have no effect on the construction or the interpretation of this Agreement.

## 2. Licence

2.1 Subject to the terms and conditions of this Licence, IMRO grants the Licensee a non-exclusive licence of the Making Available Right in the Licensed Repertoire, from the Commencement Date within the Territory only, for the sole purpose of Making Available:

- (a) Licensed Tones to User's Mobile Phones for downloading; and
- (b) Previews to Users on their Mobile Phones or other medium

via the networks and/or web/WAP sites of the Licensee and to the clients and/or web/WAP sites described in the Licensee's application for this licence.

2.2 The licence in clause 2.1 does not cover the Making Available of:

- (a) any Licensed Repertoire Work synchronised with any visual images (moving or still);
- (b) any unauthorised adaptation, parody, burlesque or arrangement of a Licensed Repertoire Work;
- (c) any Licensed Repertoire Work as or in conjunction with an advertisement, or promotional message of any kind;
- (d) any Musical Works outside the Territory;
- (e) Dramatico-Musical Works, except for Permitted Excerpts;
- (f) any Licensed Repertoire Work in any product or service that is not a Licensed Tone (by way of example only, premium line telephone services or downloading of sound recordings of Musical Works in MP3 format onto Mobile Phones).

2.3 This Licence is granted on the basis that the Licensee can provide all of the information specified in Schedule 2 including accurate details of the identity of the Licensed Repertoire Works included in a Licensed Tone, the number of uses of these Works and the revenue generated from such uses, and all other information to which IMRO is entitled under this Agreement and remains in effect only insofar as the Licensee can provide this information.

2.4 For the avoidance of doubt, the licence granted in Clause 2.1 covers the Making Available Right in the Licensed Repertoire only, and does not cover:

- (a) the reproduction or copying of any Licensed Repertoire, either by the Licensee or by any User;
- (b) any sound recording rights;
- (c) any Musical Works which are not in the Licensed Repertoire;
- (d) any moral rights of the creators of Licensed Repertoire works;
- (e) any use of any Licensed Repertoire work, where all other necessary licences or waivers for that use have not been obtained;
- (f) the rights listed in Section 40(1)(b) – (g) of the Act.

2.5 The Licensee agrees and acknowledges that the precise extent of the Licensed Repertoire and the Making Available Right are subject to all applicable laws and to the requirements of any licence, consent or agreement entered into by IMRO. In particular, their scope is determined respectively by the Musical Works vested in IMRO from time to time by its Members, the statutory provisions on copyright and

the terms of international agreements with Associated Societies. They are therefore subject to change from time to time. Information about the current Licensed Repertoire, and the scope of the Making Available Right at any particular time, is available from IMRO. It is the responsibility of the Licensee to verify whether particular Musical Works or activities are covered by this Agreement.

2.6 In the event of any substantial amendment during this Agreement to the rights administered by IMRO as of the Commencement Date, either party may require renegotiation in good faith of the terms of this Agreement without prejudice to the rights of either party.

### 3. **Warranty**

3.1 IMRO warrants that it can grant the licence granted by this Agreement.

3.2 All other warranties, whether implied under contract, by law or under statute, are hereby expressly excluded.

### 4. **Licence Payments**

#### 4.1 *Payment of Royalty*

In consideration of the licence granted by this Agreement, the Licensee shall, for each Calendar Quarter during the currency of this Agreement, calculate the amount of Royalty payable in respect of the Calendar Quarter in accordance with Schedule 3 hereto, account for the amount calculated in accordance with Clause 4.3 hereto and pay to IMRO the Minimum Quarterly Payment, or the Royalty, whichever is the greater, in accordance with the provisions of this Clause 4.

#### 4.2 *Due Dates for Payment*

The Minimum Quarterly Payment for the first Calendar Quarter in which this Agreement comes into effect, shall be paid on the Commencement Date of this Agreement. Thereafter the payment prescribed in Clause 4.1 hereof shall become due at the end of each successive Calendar Quarter and shall be accounted for and paid as prescribed in Clauses 4.3 and 4.4 hereof. If at the end of the first Calendar Quarter the amount of Royalty due exceeds the Minimum Quarterly Amount, the difference between the Royalty due and the Minimum Quarterly Amount shall be accounted for and paid at the end of that first Calendar Quarter as prescribed generally in Clauses 4.3 and 4.4 hereof.

#### 4.3 *Submission of Quarterly Statement*

The Licensee shall submit a completed Quarterly Statement within 2 weeks of the end of each Calendar Quarter, by e-mail or other electronic format acceptable to IMRO.

#### 4.4 *Invoicing and payment*

IMRO shall send the Licensee an invoice for the amount due under this Clause 4 within 7 working days of receipt of the Quarterly Statement. Save where otherwise provided on the invoice itself, payment of the invoiced amount must be paid by the 17<sup>th</sup> day of the month following the month the invoice is issued.

#### 4.5 *Direct Debit Discount*

Where the Licensee makes payment of the invoiced amount via direct debit (within the invoice payment period) it shall be entitled to a discount of 10% on the amount so paid by direct debit.

#### 4.6 *No deductions*

No deduction in respect of any tax, or any other deduction or set-off shall be made in calculating or paying any sum due under this Agreement, save as expressly provided for in this Agreement.

#### 4.7 *Index linking for Minimum Quarterly Payment and Minimum Royalty per Licensed Tone*

Following the end of each Calendar Year during this Agreement, IMRO shall be entitled to increase the Minimum Quarterly Payment and the Minimum Royalty per Licensed Tone in line with increases in the Consumer Price Index of Retail Prices on the November 1996 mid-November base, as published in the Irish Statistical Bulletin. The first such increase shall take effect on 1<sup>st</sup> January 2007 and subsequent increases annually thereafter on 1<sup>st</sup> January.

### 5. **Late payment and Late reporting**

#### 5.1 Invoicing by means of estimated payments due

- (a) Where the Licensee does not provide a Quarterly Statement within the time-frame in Clause 4.3 hereof, IMRO shall be entitled to invoice the Licensee for an estimated amount (calculated based upon previous payments and other relevant factors), and the Licensee shall be required to pay this invoice in the ordinary way in accordance with Clause 4, together with additional late payment fees calculated in accordance with Clause 5.3. This shall not relieve the Licensee of its obligation to provide a Quarterly Statement.
- (b) In the event that there is a shortfall between the amount due on foot of the estimated amount referred to in paragraph (a) of this Clause 5.1 and the amount due upon the subsequent provision of a Quarterly Statement, the Licensee will be obliged to promptly pay the entire amount, together with additional late payment fees on the shortfall, calculated in accordance with Clause 5.3.

#### 5.2 In the event that the Licensee becomes aware that the information submitted in its Quarterly Statement is either incomplete, or contains any material omission or error, (by way of example only, the omission of a Repertoire Work or the provision of incorrect information about the Repertoire Work and its use by the Licensee), then the Licensee is obliged to:

- (a) immediately inform IMRO and supply the correct information;
- (b) pay any additional sums due under Clause 4 on the basis of the correct information; and

- (c) pay the additional fees for late payment calculated in accordance with Clause 5.3.

### 5.3 Additional fees for late payment

In the event that any payment by the Licensee due under this Agreement is late, for any reason then, in addition to making that payment, the Licensee is required to pay Interest.

- 5.4 The late payment provisions of this clause are without prejudice to any other right or remedy of IMRO.

## 6. **Information and inspection**

- 6.1 Within 120 days after the end of the Calendar Year in question, the Licensee shall furnish a statement of Licensed Tone Revenue and Advertising Revenue for that Calendar Year, certified by the Licensee's auditor. IMRO shall be entitled to contact such auditors and such auditors shall promptly answer all reasonable enquiries about such statement. IMRO may call for certified accounts in respect of the Ringtone Revenue.
- 6.2 The Licensee shall keep and make available for inspection upon reasonable notice, proper records relating to the Licensee's supply of Licensed Tones and all income received by or on behalf of the Licensee relating to the supply of Licensed Tones. These records shall be open to inspection upon reasonable notice by an authorised representative of IMRO, who shall be entitled to take copies of or extracts from same. In the event that such inspection or audit should reveal any shortfall in the royalties paid from those due under this Agreement, the Licensee shall immediately make up this shortfall and reimburse IMRO for any professional charges incurred for such audit or inspection.
- 6.3 The Licensee agrees that it will also supply IMRO with any further information in its possession, power or control, reasonably requested by IMRO at any time, in order to enable IMRO to verify the Licensed Repertoire works being made available by the Licensee, the revenues received, the calculation of the Royalties payable and/or generally to verify the Licensee's compliance with this Agreement.
- 6.4 Where all or any of the services provided under this Agreement are accessible by Users only on payment of subscription or other payment (or access is otherwise limited or controlled in some way), the Licensee shall, upon request of the Licensors, use reasonable endeavours to ensure that such services are at all times accessible by IMRO free of charge, for the purposes of enabling IMRO to verify the Licensed Repertoire Works that are available to Users.
- 6.5 Without prejudice to any right in law which IMRO might have to obtain such information, and without affecting the obligation of the Licensee to provide the information required under this Agreement, the Licensee shall not provide IMRO with any information which identifies Users or which otherwise constitutes "personal data" as defined in the Data Protection Acts 1988 to 2003.

## 7. **Term and Termination**

7.1 This Agreement shall continue until terminated by either party in accordance with this Agreement.

7.2 If

- (a) a receiver, examiner or administrator is appointed over the whole or any part of either party's assets or a party is struck off the register of companies in the jurisdiction where it was incorporated or an order is made or a resolution passed for winding up a party (unless such order or resolution is part of a voluntary scheme for the reconstruction or amalgamation of the party as a solvent corporation and the resulting corporation, if a different legal person, undertakes to be bound by this Agreement), or, in the event that the Licensee is an individual, the Licensee becomes bankrupt;
- (b) a party commits any breach of its obligations under this Agreement which is not remedied within 30 days of written notice of the breach requiring its remedy; or
- (c) any substantial amendment is made to the rights administered by IMRO

then, in the case of (a) and (b), the other party, and in the case of (c) either party may terminate this Agreement forthwith by notice in writing without prejudice to any right of action accrued prior to the date of termination.

7.3 The Licensee or IMRO may terminate this Agreement upon giving three months written notice to the other.

## 8. **Information provided by Licensee**

8.1 This Agreement has been entered into on the basis of representations made by the Licensee in applying to IMRO, in particular the information set out in the Licensee's application. If any of these representations are or become materially incorrect, the licence granted under this Agreement shall no longer apply.

8.2 The Licensee is required to notify IMRO immediately of any proposed material changes in any of the information provided in its application for this licence (including without limitation, supplying Licensed Tones via additional services, or to additional clients or websites).

## 9. **Severability**

9.1 If at any time any provision of this Agreement (or any part of a provision of this Agreement) is or becomes illegal, invalid or unenforceable in any respect under the law of any jurisdiction, that shall not affect or impair:

- (a) the legality, validity or enforceability in that jurisdiction of any other provision of this Agreement (including the remainder of a provision, where only part thereof is or has become illegal, invalid or unenforceable); or
- (b) the legality, validity or enforceability under the law of any other jurisdiction of that or any other provision of this Agreement



10. **Copyright Notices**

The Licensee shall provide a notice on its content provision platform indicating that the Licensed Repertoire is being made available under licence from IMRO and that use of Musical Works is subject to restrictions under copyright law.

11. **Notices under the Agreement**

11.1 Any notice served hereunder shall be deemed to be sufficiently served if sent by post or fax to the usual or last known place of business of the addressee and proof of despatch in the case of a letter, and receipt of successful transmission report in the case of a facsimile transmission, shall be conclusive evidence of receipt by the addressee in due course of transmission. No partnership, Agency Etc. Nothing in this Agreement shall create, or be deemed to create, a partnership, or the relationship of principal and agent, or employer and employee between the parties hereto.

12. **No partnership, Agency Etc.**

12.1 Nothing in this Agreement shall create, or be deemed to create, a partnership, or the relationship of principal and agent, or employer and employee between the parties hereto.

13. **Entire Agreement**

13.1 This Agreement together with the Schedules to this Agreement comprise the entire agreement between the parties with respect to the subject matter of this Agreement and supersedes all previous agreements and understandings between the parties with respect thereto, and may not be modified except by an instrument in writing signed by the duly authorised representatives of the parties.

14. **Confidentiality**

14.1 Subject to the permitted uses and disclosures of its confidential information provided for in this clause 14.1 and in clause 14.2 hereof, IMRO shall keep confidential all confidential information provided to IMRO by The Licensee pursuant to this Agreement. The Licensee though acknowledges that IMRO may disclose the said confidential information to any of its directors, officers, employees, members or sister organisations to the extent that disclosure is reasonably necessary for the purposes of this Agreement and for the purposes of administering the Licensed Repertoire and accounting to members and sister organisations for the administration of the Licensed Repertoire.

14.2 IMRO may disclose the confidential information referred to in paragraph 14.1 if and to the extent that:

- (a) this is required by the law of any relevant jurisdiction or pursuant to a request or order of a regulator or court of a competent jurisdiction;
- (b) this is required by any securities, exchange or regulatory or governmental body to which IMRO is subject;

- (c) the information is disclosed on a strictly confidential basis to the professional advisers, auditors and bankers of IMRO;
- (d) the information has come into the public domain through no fault of IMRO;
- (e) the information was in the possession of IMRO before disclosure by the Licensee;
- (f) it is required to enable IMRO to enforce its rights under this Agreement.

## 15. **Indemnity**

15.1 IMRO shall at all times (notwithstanding the termination of this Agreement) be liable for, indemnify and hold harmless Licensee (together with its officers, servants and agents) against any and all liability, loss, damages, costs, legal costs, professional and other expenses of any nature whatsoever incurred or suffered by Licensee arising from any infringement or alleged infringement by Licensee of any third party intellectual property rights in consequence of the authorized use of Licensed Repertoire provided that :

- (a) If Licensee becomes aware of any complaint, claim, demand, threatened proceedings or proceedings arising out of its use of Licensed Repertoire, Licensee shall forthwith and without delay notify IMRO in writing giving full particulars of the circumstances.
- (b) Licensee shall make no comment or admission to any third party in respect of such circumstances without the prior consent of IMRO.
- (c) IMRO shall in its sole discretion be entitled to decide what action (including litigation, arbitration or compromise) if any to take in respect of any claim or counterclaim brought or threatened in respect of the use of its repertoire.
- (d) IMRO shall not be obliged to bring or defend any proceedings whether for copyright infringement or otherwise in relation to its repertoire if it decides in its sole discretion not to do so and Licensee shall not be entitled to bring any action or proceedings in relation to Licensed Repertoire regardless of any such decisions.
- (e) IMRO shall have the conduct of all proceedings relating to its repertoire.
- (f) Licensee will co-operate with IMRO in taking such further action at the reasonable request of IMRO as it may from time to time deem appropriate to protect its repertoire and IMRO shall meet all expenses incurred by Licensee to third parties in giving such assistance. In particular, Licensee will, at the reasonable request of IMRO, give full co-operation to IMRO (including the provision of documentation and making relevant people available) in any action, claim or proceedings brought or threatened in respect of IMRO's repertoire.
- (g) IMRO shall be entitled to retain any payment including any damages or costs award from any third party arising out of any dispute relating to the use of its repertoire under this Agreement.

- (h) In any proceedings which are brought or defended by IMRO, IMRO shall be entitled to claim in respect of any loss suffered or likely to be suffered by Licensee but IMRO shall be entitled to retain any damages awarded in respect of such claim and the provisions of any applicable law, insofar as the same may apply to the contrary, are hereby, to such extent only, expressly excluded.
  - (i) If at any time an allegation of infringement of third party rights is made in respect of Licensed Repertoire or, if in Licensee's reasonable opinion such an allegation is likely to be made, IMRO may at its own expense take such action as it deems appropriate, including modifying its repertoire, so as to avoid the infringement.
- 15.2 Licensee understands and agrees that the use of Licensed Repertoire and any other material provided to it under this Agreement is subject to all applicable laws, enactments, regulations and other similar instruments (including, without limitation, all applicable local laws relating to advertising, broadcasting, health and safety and telecommunications), and that Licensee shall at all times be solely liable and responsible for such due observance and performance. IMRO shall not be liable to indemnify to Licensee for any payment or costs arising as a result of its failure to comply with all applicable laws.
- 15.3 Licensee shall at all times (notwithstanding the termination of this Agreement) be liable for, indemnify and hold harmless IMRO (together with its officers, servants and agents) against any and all liability, loss, damages, costs, legal costs, professional and other expenses of any nature whatsoever incurred or suffered by IMRO arising out of the breach or non-performance by Licensee of this Agreement.
- 16. Miscellaneous**
- 16.1 The Licensee agrees that it will utilise any industry anti-piracy security standards that are developed and until that time employ reasonable anti-piracy measures in its use of the Licensed Repertoire.
- 16.2 This Agreement is personal to the Licensee. The Licensee shall not be entitled to assign this Agreement or any of its rights and obligations hereunder without the prior written consent of IMRO, such consent not to be unreasonably withheld.
- 16.3 The failure of any party to exercise or enforce any right under this Agreement shall not be deemed to be a waiver of that right nor operate to bar the exercise or enforcement of it or any other right at any time.
- 16.4 This Agreement shall be governed by and construed under the laws of the Republic of Ireland and both parties hereby submit to the non-exclusive jurisdiction of the Irish courts.

IN WITNESS WHEREOF the parties have executed this Agreement on the date written above.

\_\_\_\_\_  
Signed for and on behalf of  
IMRO

Date: \_\_\_\_\_

\_\_\_\_\_  
Signed for and on behalf of  
[LICENSEE]

Date: \_\_\_\_\_

\_\_\_\_\_  
Signed for and on behalf of  
[LICENSEE]

Date: \_\_\_\_\_

**Schedule 1**

**Form of Accounting Statement**

Company name: \_\_\_\_\_  
Contact name: \_\_\_\_\_  
Quarter ending: \_\_\_\_\_  
Purchase Order No. \_\_\_\_\_

**Revenue for the Quarter**

- 1 Sum of fees paid per Supply of Licensed Tones:
- 2 Other Licensed Tone Revenue apart from fees per Supply:
- 3 Advertising Revenue:

Gross Revenue for the Quarter: \_\_\_\_\_

**Royalty Calculation**

Royalty payable in respect of paragraph 1 above (5% revenue per Licensed Tone or Minimum Royalty per Licensed Tone):

Royalty payable in respect of paragraph 2 above (5% of relevant revenues):

Royalty payable in respect of paragraph 3 above (5% of relevant revenues):

**Total Royalty:** \_\_\_\_\_

(Due subject to application of Minimum Quarterly Amount pursuant to Clause 4.1 of the IMRO Copyright License for Ringtones/Ringbacks)

**Signed for and  
On behalf of [Licensee] by:** \_\_\_\_\_

**Date supplied:** \_\_\_\_\_

## Schedule 2

### Information to be provided in the Licensee's Quarterly Statement

1. Details of how Licensed Tone Revenues received for the Calendar Quarter were earned including:

Number of Licensed Tone Previews  
 Amounts charged per preview (if applicable)  
 Number of Licensed Tone Downloads  
 Amounts charged per download  
 Number of transactions where Licensed Tones sold as part of bundled goods or services  
 Amounts charged per transaction  
 Amount attributable to Ringtones in each transaction  
 Other sources of income for Licensed Tones

2. Details of how Advertising Revenues received for the Calendar Quarter were earned including:

Advertising, subscription or sponsorship revenue received in respect of the website from which Licensed Tones are sold  
 Total traffic on site  
 Proportion traffic attributable to Licensed Tone Preview / Download

3. Details of any deductions made in calculating Royalty (with supporting documentation)

2. In the case of each Musical Work used by the Licensee:

• Title of the work	
• Ringtone or Ringbacktone	
• Name of composer	
• Name of performing artist	
• Names of the original publisher (if available)	
• Any unique electronic identifier (such as MCPS Tune Code)	
• Cost per download to User	
• Number of times work was downloaded in the preceding Calendar Quarter	

(\*Tables of information about Ringtones and about Ringbacktones should be grouped separately and identified as such)

### Schedule 3

1. **Minimum Quarterly Payment - €387.23**
2. **Royalty Rate – 5%**
3. **Minimum Royalty per Licensed Tone - €0.08**
4. **Calculation of Royalty**

The Royalty payable for each Calendar Quarter shall be:

- (a) The sum of amounts calculated separately for each Licensed Tone Supplied during the Calendar Quarter as follows – for each Licensed Tone supplied, 5% of the actual fee charged (ex VAT) or the Minimum Royalty per Licensed Tone of €0.08, whichever is the greater; plus
- (b) 5% of fees charged (ex VAT) in respect of exploitation of the Licensed Tones other than exploitation by Supply dealt with at (a) above; plus
- (c) 5% of Advertising Revenue,

PROVIDED THAT the following shall apply to the said calculation of Royalty payable per Calendar Quarter:

- (i) the fees and revenues referred to shall be those charged in respect of (a), (b) and (c) above by the Licensee, any affiliate, associate, agent or representative of the Licensee or any intermediary through whom Licensed Tones are Made Available to Users under this Licence;
- (ii) the Licensee shall be permitted to deduct in respect of any single Licensed Tone from the calculation at (a) above any fee or any Minimum Royalty per Licensed Tone that relates to a Licensed Tone that was technically defective and in respect of which a deduction was given or would have been given if a fee were charged;
- (iii) for the purposes of the calculation at (a) above, where Licensed Tones are Supplied to Users as part of a bundle of other goods and/or services, the portion of the fee paid for the said bundled goods and/or services that will be deemed attributable to supply of the Licensed Tones, shall reflect the relative value of the Licensed Tones Supplied as compared with the other goods and services provided. For the avoidance of doubt and depending on the resulting attributed value, the Minimum Royalty per Licensed Tone supplied may become applicable.

\*Note: As set out in Clause 4.7, the Minimum Quarterly Payment and the Minimum Royalty per Licensed Tone Supplied are subject to increases in line with increases in the Consumer Price Index of Retail Prices on the November 1996 mid-November base, as published in the Irish Statistical Bulletin following the end of each Calendar Year during this Agreement. The first such increase shall take effect on 1<sup>st</sup> January 2007 and subsequent increases annually thereafter on 1<sup>st</sup> January.



# Online excluding JOL Music Services & Ringtones/Ringbacks

AN AGREEMENT made the \_\_\_\_\_ day of \_\_\_\_\_ 2024

**BETWEEN (1) IRISH MUSIC RIGHTS ORGANISATION CLG** whose registered office is at Copyright House, Pembroke Row, Lower Baggot Street, Dublin 2 ("IMRO") and **(2)XXXXXX**, whose registered office is at XXXXXXXXXXXXXXXXXXXXXXXXXXXXXXXX ("the Licensee")

**WHEREAS:**

- A. The Licensee wishes to make available to the public by wire or wireless means musical works and/or words associated therewith in the repertoire of IMRO (as hereinafter defined), and
- B. The service operated by the Licensee is not one to which the 'Joint MCPSI and IMRO Licensing Scheme for the Provision of Online and Mobile Music Services to the Public for Private Use' or 'Joint MCPSI and IMRO Limited Online Exploitation License for Private Use' should apply, and,
- C. The service operated by the Licensee is not one that involves the making available of musical works and/or words associated therewith, as part of a ringtone/ringback service.

**NOW IT IS HEREBY AGREED** as follows:-

- 1. In this agreement, unless the context otherwise requires:-
  - (a) "making available to the public" shall have the meaning of any act referred to in Section 40(1)(a) of the [Copyright and Related Rights Act 2000](#).
  - (b) "copyright owner" shall mean in respect of any act in relation to a musical work, or words associated therewith, the person in whom for the time being is vested the right to authorise other persons to do that act.
  - (c) "dramatico-musical work" shall mean an opera, operetta, musical play, revue or pantomime, insofar as it consists of words and music written expressly therefor.
  - (d) "licence year" shall mean a period of 12 months beginning on 1st January and any subsequent anniversary thereof.
  - (e)
    - (i) "net advertising revenue" shall mean the gross advertising revenue of the Licensee less only any advertising agency, selling agent or Licensee's sales person's commission, wages or other costs calculated by reference to gross advertising revenue but not exceeding the total 20% of such gross advertising revenue.
    - (ii) "net revenue" shall mean the aggregate of net advertising revenue, all income received from subscribers, donations, the provision of marketing information and income received for the direct sponsorship of programmes or services less actual bad debts.
  - (f) "repertoire of IMRO" shall mean all or any musical works including any words associated therewith in which rights to make available to the public and to authorise others to do the same are or may be at any time during the term of this Agreement vested in IMRO in the territory.

## **Online excluding JOL Music Services & Ringtones/Ringbacks**

2. Subject to the exemptions and limitations above, and hereinafter set out, IMRO hereby grants to the Licensee licence and authority to make available the repertoire of IMRO.
  
3.
  - (i) The extent of the licence and authority hereby granted is set out in Schedule I hereto which schedule may be amended from time to time pursuant to any change in the extent of rights administered by IMRO. IMRO shall inform the Licensee in advance, if possible, if not as soon as possible thereafter of any change so made and shall supply the Licensee with a revised version of Schedule I.
  
  - (ii) In the event of any substantial amendment to Schedule I either party may require renegotiation in good faith of the terms of this Agreement without prejudice to the rights of either party under Clause 7.
  
4. In consideration of the licence and authority hereby granted the Licensee shall make payments to IMRO in accordance with the provisions set out in Schedule II hereto. In the event that the Licensee shall be in arrears for 45 days after receipt of invoice from IMRO the Licensee shall pay IMRO interest on the amount overdue calculated on a daily basis at the rate of 6 per cent per annum without prejudice to IMRO's rights of termination under Clauses 7 and 8.
  
5. The Licensee shall supply to IMRO lists identifying, to the reasonable satisfaction of IMRO and in an electronic form acceptable to IMRO, details of musical works (and any words associated therewith) included in the making available to the public right, these lists to be supplied within 2 weeks of the end of each calendar quarter and will include title of the work, composer/artist, cost per download and number of times each work was downloaded during the preceding quarter.
  
6. Each of the parties hereto shall during the continuance in force of this agreement furnish to the other promptly all information in its possession sufficient to enable either party to protect its interests; and in particular the Licensee shall furnish to IMRO information as to the extent, if any, to which the Licensee derives, through making available to the public, revenue from sources other than advertising, subscribers, donations, sponsorship or provision of marketing information.
  
7. If
  - (a) either IMRO or the Licensee goes into receivership or any resolution is passed for its winding-up or liquidation (other than for the purposes of reconstruction or amalgamation)
  
  - (b) any substantial amendment is made to Schedule I by IMRO pursuant to clause 3
  
  - (c) either party commits any breach of its obligations under this Agreement which is not remedied within 30 days of written notice of the breach requiring its remedy

then the other party may terminate this Agreement forthwith by notice in writing without prejudice to any right of action accrued prior to the date of termination.

## **Online excluding JOL Music Services & Ringtones/Ringbacks**

8. This Agreement shall be deemed to have commenced on \_\_\_\_\_ and shall continue from year to year unless terminated by either party giving to the other 1 calendar month's notice or unless terminated in accordance with clause 7 above.
  
9. This Agreement is personal to the Licensee. The Licensee shall not be entitled to assign any of its rights and obligations hereunder without the prior written consent of IMRO, unless in the event of any amalgamation or reconstruction of its business, such consent not to be unreasonably withheld.
  
10. This Agreement shall be construed under the laws of the Republic of Ireland and both parties hereby submit to the non-exclusive jurisdiction of the Irish courts.

**AS WITNESS** the hand of \_\_\_\_\_ for and on behalf of IMRO

and the hand of \_\_\_\_\_ for and on behalf of the Licensee

# **Online excluding JOL Music Services & Ringtones/Ringbacks**

## **SCHEDULE I**

The licence granted in clause 2 of this Agreement **shall not** extend to nor authorise the making available of:-

1. a dramatico-musical work; provided that the rights administered by IMRO do nevertheless include the right to make available on radio an excerpt or excerpts from a dramatico-musical work the total duration of which in the course of the same programme does not exceed 25 minutes or 25% of the total length of the work whichever shall be the shorter and which excerpt or excerpts -
  - (i) are not a "potted" version of the work or
  - (ii) are not or do not cover a complete act of the work;
2. words written for the purpose of a commercial advertisement unless such words are sung to music specially written for a commercial advertisement or to non-copyright music and the sung performance has a duration of not less than five seconds;
3. unless specifically authorised in writing by IMRO or the copyright owner
  - (a) any musical work accompanied by any words other than those (if any) published or otherwise associated therewith by the copyright owner;
  - (b) any musical work with or without associated words in any adapted or rearranged form in such manner as to produce parodied or burlesqued effects;
4. any musical work, with or without associated words, in a dramatic form. A dramatic form shall be deemed to be created only by performance in a programme in which there is a distinct plot depicted by authors and where the story of the musical work and/or its associated words is woven into and carries forward the plot and its accompanying action. (A dramatic form shall not for example be deemed to be created by the use of costumes, scenery and/or dance routine merely to provide an acceptable presentation of the work). For the purposes of this paragraph, the word "actors" shall include actor-singers, mimers and/or puppets;
5. any musical work by means of a recording if the making of such recording infringed the copyright in such work;
6. any words associated with a musical work or ballet if unaccompanied by the music thereof;
7. musical works as part of an online and mobile service where such music is a substantial part of that service and where either the 'Joint MCPSI and IMRO Licensing Scheme for the Provision of Online and Mobile Music Services to the Public for Private Use' or 'Joint MCPSI and IMRO Limited Online Exploitation License for Private Use' should apply;
8. musical works as part of a ringtone and/or ringback service;

## **Online excluding JOL Music Services & Ringtones/Ringbacks**

9. the making available of musical works to users outside the Republic of Ireland.

### **SCHEDULE II**

1. The royalty payable for any licence year shall be determined as follows:-

(a)

<b>Net Revenue</b>	<b>Royalty Rate</b>
<b>First</b> €2,010,718	4.0%
<b>Next</b> €3,351,265	5.5%
<b>to</b> €5,361,982	
<b>Next</b> €5,361,982	6.25%
<b>to</b> €10,723,966	
<b>Next</b> €10,723,966	7.5%
<b>to</b> €16,085,984	
<b>Above</b> €16,085,984	9.0%

(b) The minimum annual royalty charge is:-

(i) Personal website	€ 181
(ii) Incidental music only on commercial website	€ 907.86
(iii) Webcasting/Streaming	€1,869.72
(iv) All other uses	€3,816.71

(c) The foregoing net revenue tranches and minima are related to the Consumer Price Index of Retail Prices for October 2022 (on the November 1996 base), as published in the Irish Statistical Bulletin, and will be adjusted on each subsequent anniversary of that date in proportion to annual changes in that Index and shall be rounded to the nearest Euro.

**Online excluding JOL Music Services &  
Ringtones/Ringbacks**

Date:

**IRISH MUSIC RIGHTS  
ORGANISATION LIMITED BY  
GUARANTEE**

and

XXXXXX

---

**L I C E N C E  
A G R E E M E N T**

---

# **IMRO Licensing Scheme for the Provision of Online and Mobile Download Music Services to the Public for Private Use**

**AN AGREEMENT** made

**BETWEEN (1) IRISH MUSIC RIGHTS ORGANISATION LIMITED BY GUARANTEE** whose registered office is at Copyright House, Pembroke Row, Lower Baggot Street, Dublin 2 ("IMRO") and [\_\_\_\_\_], whose registered office is at [\_\_\_\_\_], ("the Licensee")

## **WHEREAS:**

- A. The Licensee wishes to Make Available to the Public by wire or wireless means Musical Works and/or words associated therewith in the Repertoire of IMRO (as hereinafter defined), and
- B. The service operated by the Licensee is not one to which the 'Joint MCPSI and IMRO Licensing Scheme for the Provision of Online and Mobile Music Services to the Public for Private Use' or 'Joint MCPSI and IMRO Limited Online Exploitation License for Private Use' should apply, and,
- C. The service operated by the Licensee is not one that involves the Making Available to the Public of Musical Works and/or words associated therewith, as part of a ringtone/ringback service.

**NOW IT IS HEREBY AGREED** as follows:-

1. In this agreement, unless the context otherwise requires:-

<b>"Applicable Revenue"</b>	means the Gross Revenue less VAT (or other equivalent sales tax, as applicable).
<b>"Copyright Owner"</b>	shall mean in respect of any act in relation to a Musical Work, or words associated therewith, the person in whom for the time being is vested the right to authorise other persons to do that act.
<b>"Download Music Service"</b>	shall mean a music service falling within the definition set out in schedule 2.
<b>"Dramatico-musical Work"</b>	shall mean an opera, operetta, musical play, revue or pantomime, insofar as it consists of words and music written expressly therefor.
<b>"Excluded Service"</b>	means any service (or the relevant part of a service) which is a podcasting service or which falls within the scope (from time to time) of any of the following MCPSI/IMRO joint licensing schemes or any licensing schemes operated by IMRO or MCPSI (Mechanical Copyright

# **IMRO Licensing Scheme for the Provision of Online and Mobile Download Music Services to the Public for Private Use**

Protection Society Ireland Ltd.)

- a) IMRO – Ringtone/Ringback Licensing Scheme
- b) MCPSI – Ringtone Licensing Scheme
- c) MCPSI – Ringback Licensing Scheme
- d) MCPSI – Karaoke and MIDI Scheme
- e) MCPSI – Music-on-hold Scheme
- f) MCPSI – Supply of Background Music Services Scheme
- g) MCPSI – Premium Telephone Line Services Scheme
- h) IMRO/MCPSI – Limited On-Line Exploitation Licensing Scheme
- i) IMRO/MCPSI - General Entertainment on Demand Licensing Scheme
- j) IMRO/MCPSI – Licensing Scheme for the Provision of Online and Mobile Music Services to the Public for Private Use
- k) IMRO - Online excluding JOL Music Services & Ringtones/Ringbacks

## **“Gross Revenue”**

shall mean:

- a) all revenue received (or receivable) by the Licensee from Users in relation to the provision of the Licensed Services; and
- b) all revenue received (or receivable) by the Licensee as a result of the placement of advertising on or within the Licensed Services; and
- c) all revenue received (or receivable) by the Licensee as sponsorship fees in relation to the provision of the Licensed Services; and
- d) all revenue received (or receivable) in the form of commissions from third parties as a result of Users accessing and/or purchasing



# **IMRO Licensing Scheme for the Provision of Online and Mobile Download Music Services to the Public for Private Use**

from a service of a third party via the Licensed Services; and

- e) any other revenue received (or receivable) by the Licensee arising in relation to the provision to Users of the Licensed Services (including, without limitation, such revenue received in relation to donations, barter or contra deals, such deals to be valued for these purposes);
- f) and in each of the above cases such revenue shall, for the avoidance of doubt, include any such revenue whether received or receivable by the Licensee or any associate, affiliate, agent or representative of such party.
- g) There shall be no other deduction or set-off from the above revenues other than refunds to Users for services that they were unable to use due to technical faults in the Licensed Services.

<b>"Licence Year"</b>	shall mean a period of 12 months beginning on 1st January and any subsequent anniversary thereof.
<b>"Licensed Service"</b>	shall mean the music service listed in schedule 4.
<b>"Making Available to the Public"</b>	shall have the meaning of any act referred to in Section 40(1)(a) of the <a href="#">Copyright and Related Rights Act 2000</a> .

# **IMRO Licensing Scheme for the Provision of Online and Mobile Download Music Services to the Public for Private Use**

<b>“Musical Work”</b>	means any musical work (as defined in the Act) and any lyrics or words written to be used with such musical work (if applicable). It includes any part of such a work.
<b>“Network”</b>	means the internet, a mobile network or any other wired or wireless network.
<b>"Repertoire of IMRO"</b>	shall mean all or any Musical Works including any words associated therewith in which rights to Make Available to the Public and to authorise others to do the same are or may be at any time during the term of this Agreement vested in IMRO in the territory.
<b>“Territory”</b>	means the Republic of Ireland
<b>“User”</b>	means a natural person in the Territory who receives the Licensed Services for their own private and non-commercial use.

2. Subject to the exemptions and limitations above, and hereinafter set out, IMRO hereby grants to the Licensee licence and authority to Make Available to the Public the Repertoire of IMRO.
3.
  - (i) The extent of the licence and authority hereby granted is set out in Schedule I hereto which schedule may be amended from time to time pursuant to any change in the extent of rights administered by IMRO. IMRO shall inform the Licensee in advance, if possible, if not as soon as possible thereafter of any change so made and shall supply the Licensee with a revised version of Schedule 1.
  - (ii) In the event of any substantial amendment to Schedule 1 either party may require renegotiation in good faith of the terms of this Agreement without prejudice to the rights of either party under Clause 7.
4. In consideration of the licence and authority hereby granted the Licensee shall make payments to IMRO in accordance with the provisions set out in Schedule 3 hereto. In the event that the Licensee shall be in arrears for 45 days after receipt of invoice from IMRO the Licensee shall pay IMRO interest on the amount overdue calculated on a daily basis at the rate of 6 per cent per annum without prejudice to IMRO's rights of termination under Clauses 7 and 8.

## **IMRO Licensing Scheme for the Provision of Online and Mobile Download Music Services to the Public for Private Use**

5. The Licensee shall supply to IMRO lists identifying, to the reasonable satisfaction of IMRO and in an electronic form acceptable to IMRO, details of Musical Works (and any words associated therewith) included in the Making Available to the Public right, these lists to be supplied within 2 weeks of the end of each calendar quarter and will include title of the work, composer/artist, cost per download and number of times each work was downloaded during the preceding quarter.
  
6. Each of the parties hereto shall during the continuance in force of this agreement furnish to the other promptly all information in its possession sufficient to enable either party to protect its interests.
  
7. If
  - (a) either IMRO or the Licensee goes into receivership or any resolution is passed for its winding-up or liquidation (other than for the purposes of reconstruction or amalgamation)
  
  - (b) any substantial amendment is made to Schedule I by IMRO pursuant to clause 3
  
  - (c) either party commits any breach of its obligations under this Agreement which is not remedied within 30 days of written notice of the breach requiring its remedy then the other party may terminate this Agreement forthwith by notice in writing without prejudice to any right of action accrued prior to the date of termination.
  
8. This Agreement shall continue until the 31<sup>st</sup> December 2024 unless terminated by either party giving to the other 1 calendar month's notice or unless terminated in accordance with clause 7 above.
  
9. This Agreement is personal to the Licensee. The Licensee shall not be entitled to assign any of its rights and obligations hereunder without the prior written consent of IMRO, unless in the event of any amalgamation or reconstruction of its business, such consent not to be unreasonably withheld.
  
10. This Agreement shall be construed under the laws of the Republic of Ireland and both parties hereby submit to the non-exclusive jurisdiction of the Irish courts.

**AS WITNESS** the hand of \_\_\_\_\_ for and on behalf of IMRO

and the hand of \_\_\_\_\_ for and on behalf of the Licensee

# **IMRO Licensing Scheme for the Provision of Online and Mobile Download Music Services to the Public for Private Use**

## **SCHEDULE 1**

For the avoidance of doubt, the licence granted in Clause 2 covers the Making Available to the Public Right in the Licensed Repertoire only, and does not cover the reproduction or copying of any Licensed Repertoire, either by the Licensee or by any User.

The licence granted in clause 2 of this Agreement **shall not** extend to nor authorise the Making Available to the Public of:-

1. a Dramatico-musical Work;
2. words written for the purpose of a commercial advertisement unless such words are sung to music specially written for a commercial advertisement or to non-copyright music and the sung performance has a duration of not less than five seconds;
3. unless specifically authorised in writing by IMRO or the Copyright Owner
  - (a) any musical work accompanied by any words other than those (if any) published or otherwise associated therewith by the copyright owner;
  - (b) any musical work with or without associated words in any adapted or rearranged form in such manner as to produce parodied or burlesqued effects;
4. any Musical Work, with or without associated words, in a dramatic form. A dramatic form shall be deemed to be created only by performance in a programme in which there is a distinct plot depicted by authors and where the story of the Musical Work and/or its associated words is woven into and carries forward the plot and its accompanying action. (A dramatic form shall not for example be deemed to be created by the use of costumes, scenery and/or dance routine merely to provide an acceptable presentation of the work). For the purposes of this paragraph, the word "actors" shall include actor-singers, mimers and/or puppets;
5. any Musical Work by means of a recording if the making of such recording infringed the copyright in such work;
6. any words associated with a Musical Work or ballet if unaccompanied by the music thereof;
7. Musical Works as part of an online and mobile service where such music is a substantial part of that service and where either the 'Joint MCPSI and IMRO Licensing

## **IMRO Licensing Scheme for the Provision of Online and Mobile Download Music Services to the Public for Private Use**

Scheme for the Provision of Online and Mobile Music Services to the Public for Private Use' or 'Joint MCPSI and IMRO Limited Online Exploitation License for Private Use' should apply;

8. Musical Works as part of a ringtone and/or ringback service;
9. the Making Available to the Public of Musical Works to users outside the Republic of Ireland.

**IMRO Licensing Scheme for the Provision of Online and  
Mobile Download Music Services to the Public for Private  
Use  
SCHEDULE 2**

**Definition of Download Music Service**

**“Permanent Download Service”**

means a service (or the relevant part of a service), other than an Excluded Service, by which a Musical Work is made available to the public via a Network in the form of a download and where such download may be retained by the User on a permanent basis, and the term “Permanent Download” shall be construed accordingly.

# IMRO Licensing Scheme for the Provision of Online and Mobile Download Music Services to the Public for Private Use

## SCHEDULE 3

1. The royalty payable for any licence year shall be determined as follows:-

(a)

<b>Service</b>	<b>Royalty Rate of Applicable Revenue</b>	<b>Minimum Royalty (Applicable if Greater than Royalty Rate)</b>
<b>Permanent Download Service</b>	<b>4%</b>	Number of Musical Works in bundle Royalty per Musical Work downloaded
		1 – 7                            €0.037
		8 – 12                           €0.030
		13 -17                          €0.027
		18 – 29                         €0.022
		30 or more                     €0.020

# **IMRO Licensing Scheme for the Provision of Online and Mobile Download Music Services to the Public for Private Use**

## **SCHEDULE 4**

### **Licence Details**

<b>Licensee</b>	
<b>Licensee Registered Address</b>	
<b>Agreement Number</b>	
<b>Licensed Services</b>	
<b>Additions to Definitions of "Territory"</b>	



**IMRO Licensing Scheme for the Provision of Online and  
Mobile Download Music Services to the Public for Private  
Use**

Date:

**IRISH MUSIC RIGHTS  
ORGANISATION LIMITED BY  
GUARANTEE**

and

---

**L I C E N C E  
A G R E E M E N T**

---

# IMRO/MCPSI JOINT GENERAL ENTERTAINMENT ON-DEMAND LICENCE FOR CABLE OPERATORS 2024

<b>NAME OF LICENSEE</b>	[REDACTED]
<b>REGISTERED ADDRESS OF LICENSEE</b>	[REDACTED]
<b>NAME OF THE LICENSORS</b>	IRISH MUSIC RIGHTS ORGANISATION CLG ('IMRO');  AND  Mechanical Copyright Protection Society of Ireland Limited ('MCPSI')
<b>REGISTERED ADDRESSES OF LICENSORS</b>	Copyright House, Pembroke Row, Lower Baggot Street, Dublin 2, Ireland
<b>LICENSED SERVICES</b>	<p>"Standard Limited On Demand Streaming Service"</p> <p>"Premium Limited On Demand Streaming Service"</p> <p><b>both of which are available only on the Licensees Cable Programme Service (as defined in the Copyright &amp; Related Rights Act 2000)</b></p> <p>(the "Licensed Services")</p>
<b>COMMENCEMENT DATE</b>	1 <sup>st</sup> January 2024 ("the Commencement Date")
<b>ROYALTY FEES</b>	Royalties payable as set out in clause 5
<p><b>Clarification</b></p> <p>(a) For the avoidance of doubt, revenue which relates solely to services other than those derived from the Licensed Services shall not be included in the Gross Revenue.</p> <p>(b) For the further avoidance of doubt, Gross Revenue shall not be reduced by credit card commissions or similar payment process charges.</p>	

Signed on behalf of the Licensee:

\_\_\_\_\_ Date: \_\_\_\_\_

**Signed on behalf of the Mechanical-Copyright Protection Society Ireland Limited (“MCPSI”) of Copyright House, Pembroke Row, off Lower Baggot Street, Dublin 2 contracting for and as agent on behalf of MCPS and for and on behalf of and as agent of the various members and affiliated Societies of MCPS:**

\_\_\_\_\_ Date: \_\_\_\_\_

**Signed on behalf of the IRISH MUSIC RIGHTS ORGANISATION CLG (“IMRO”) of Copyright House, Pembroke Row, off Lower Baggot Street, Dublin 2, contracting on behalf of itself and for and on behalf of and as agents of its affiliated societies:**

\_\_\_\_\_ Date: \_\_\_\_\_

# JOINT IMRO AND MCPSI SHORT-TERM GENERAL ENTERTAINMENT ON- DEMAND LICENCE

## TERMS AND CONDITIONS

### 1. Definitions

“**the Act**” means the Copyright and Related Rights Act 2000, as amended from time to time.

“**Active Subscriber**” means a Base Subscriber who Streams at least thirty (30) seconds of any one (1) piece of Audio-Visual Material in the calculable monthly period.

“**Agreement**” means these terms and conditions and the cover sheet to these terms and conditions.

“**Audio-Visual Material**” means an On Demand Event in which there is presentation of Musical Works in conjunction with images, whether moving or still.

“**AV Usage Report**” means the information set out in the Licensors’ reporting format as set out in Schedule 2

“**Base Subscriber**” means any Cable Subscriber who can access the Licensed Services via the Licensees Cable Programme Service in a calculable monthly period.

“**Cable Programme**” and “**Cable Programme Service**” shall have the meaning given to them in the Act.

“**Cable Subscriber**” means a natural person in the Territory who subscribes to the Cable Programme Service offered by the Licensee for their own private and non-commercial use.

“**Commencement Date**” means the date as stated on the cover sheet of this Agreement.

“**Commercial Work**” means any Repertoire Work other than:

- (a) one where the Member owning or controlling the copyright in such Repertoire Work has authorised MCPSI to license it as so-called production or library music; or
- (b) a Commissioned Work, PROVIDED THAT for the purposes of clause 4.3, a Commissioned Work shall not be excluded from such definition where the commissioning agreement does not authorise the Licensee to use the Commissioned Work in the context set out in those clauses.

“**Commissioned Work**” means a Musical Work specially and expressly commissioned by the Licensee from composer/writer members of IMRO and/or MCPSI.

“**Dramatico-Musical Work**” means any ballet, opera, operetta, musical, musical play or work of a similar nature.

“**Gross Revenue**” means, all revenue received (or receivable) by the Licensee from Cable Subscribers in consideration solely for the provision of the Licensed Services; and such revenue shall, for the avoidance of doubt, include any such revenue whether received or receivable by the Licensee or any associate, affiliate, agent or representative of such party less any applicable sales taxes or VAT applicable to the provision of same.

“**Address**” means the residential address of a Licensee Cable Subscriber.

“**the Internet**” means the international network of computers which uses an addressing system and transmission protocol controlled by the World Wide Web consortium or its successors.

“**Licensed Service(s)**” means the service set out on the cover sheet of this Agreement.

“**Licensee**” means [REDACTED]

“**Licensors**” means IMRO and MCPSI.

“**MCPS**” means Mechanical-Copyright Protection Society Limited whose registered office is at 2<sup>nd</sup> Floor, Synergy House, 114-118 Southampton Row, London. WC1B 5A, UK.

“**Member**” means:

- (a) in the case of MCPS, each person, firm or company who or which, from time to time, has appointed MCPS as agent in relation to general entertainment on demand exploitation either before or during the Term, PROVIDED THAT a member who has so appointed MCPS after the commencement of the Term shall only be regarded as a member for the purposes of this Agreement with effect from the date on which the Member so appointed MCPS; and
- (b) in the case of IMRO, any person, firm or company who or which, from time to time, pursuant to the Articles of Association of IMRO has been admitted either before or during the Term as a member of IMRO, PROVIDED THAT a member who has been so admitted after the commencement of the Term shall only be regarded as a member for the

purposes of this Agreement with effect from the date of admission into IMRO.

**“Month”** means each calendar month or part thereof throughout the Term.

**“Musical Work”** means any musical work (as defined in the Act) and any lyrics or words written to be used with such musical work (if applicable). It includes any part of such a work.

**“On Demand Event”** means any movie, television programme, or other event ordered via On Demand TV

**“On Demand TV”** means Licensee’s On Demand TV service

**“Permitted Excerpts”** refers only to Dramatico-Musical Works and means excerpts where the use of all such excerpts in any Audio-Visual Material complies with all the following limitations:

- (a) the total duration of the excerpts does not exceed 20 minutes;
- (b) the use is not a "potted version" of the Dramatico-Musical Work;
- (c) the use is not or does not cover a complete act of the Dramatico-Musical Work;
- (d) each excerpt is not presented in a "dramatic form" as defined below; and
- (e) as regards ballets specifically devised for television or excerpts from existing ballets, the total duration does not exceed five minutes.

A dramatic form shall be deemed to be created only by a performance in which there is a distinct plot depicted by actors and where the story of the Dramatico-Musical Work and/or its associated words is woven into and carries forward the plot and its accompanying action (a dramatic form shall not, for example, be deemed to be created by the use of costume, scenery, and/or any dance routine merely to provide an acceptable presentation of the work). For the purposes of this paragraph the word "actors" shall include actors, singers, mimics and/or puppets.

**“Premium Limited On Demand Streaming Service”** means the relevant part of the Licensed Service whereby a Cable Subscriber:

- (a) Is a Base Subscriber; and
- (b) may receive Audio-Visual Material via the Licensed Service by Streaming on-demand via the Cable Programme Service, where the time at which such Audio-Visual Material is received is selected by the Cable Subscriber, but where such Audio-Visual Material may not be retained by the Cable Subscriber on a permanent basis; and

- (c) pays to the Licensee a once off fee in order to access the Audio-Visual Material for a limited time period not exceeding 48 hours.

**“Repertoire Work”** means:

- (a) in relation to the licence granted by MCPSI, each Musical Work the relevant copyright in which is owned or controlled, from time to time, by MCPS or a Member or an associated society or an associated society member PROVIDED THAT (i) if one or more of those who own or control the copyright in a relevant Repertoire Work is not MCPS or a Member or an associated society or associated society member, the expression "Repertoire Work" shall only apply to such interest in the Repertoire Work as is owned or controlled by MCPS or the associated society or the relevant Member or associated society member, and (ii) it shall exclude any Musical Works that a Member of MCPS or an associated society has withdrawn or withheld from this Agreement; and
- (b) in relation to the licence granted by IMRO, each Musical Work the relevant copyright in which is owned or controlled, from time to time, by IMRO or a Member or an associated society or an associated society member PROVIDED THAT if one or more of those who own or control the copyright in a relevant Repertoire Work is not IMRO or a Member or an associated society or associated society member, the expression "Repertoire Work" shall only apply to such interest in the Repertoire Work as is owned or controlled by IMRO or the associated society or the relevant member or associated society member.

For the avoidance of doubt, if a Musical Work is a Repertoire Work in relation to one Licensor and not the other, then it remains a Repertoire Work under this Agreement in relation only to the licence granted by that Licensor.

**“Royalty Fees”** means the royalties payable, as set out in clause 5 of this Agreement.

**“RTÉ content”** means Audio-Visual Material produced by and supplied to the Licensee by Radió Telefís Éireann.

**“Service Provider”** means, the Licensee.

**“Sky Content”** means Audio-Visual Material produced by and supplied to the Licensee by British Sky Broadcasting Limited.

**“Standard Limited On Demand Streaming Service”** means the relevant part of the Licensed Service whereby a Cable Subscriber:

- (a) Is a Base subscriber; and
- (b) may receive Audio-Visual Material via the Licensed Service by Streaming on-demand via the Cable Programme Service, where the time at which such Audio-Visual Material is received is selected by the Cable Subscriber, but where such Audio-Visual Material may not be retained

by the Cable Subscriber on a permanent basis;  
and

- (c) gains access, only while they continue to be a Base Subscriber.

**“Stream”/ “Streaming”** means the making available to the public, under Sec 40 (1) (a) of the Act, of the Audio-Visual Material.

**“Term”** means the period starting on the Commencement Date and ending upon the date set out in clause 10.1 (unless terminated earlier under clauses 10.2 or 10.3).

**“Territory”** means the Republic of Ireland only

**“TG4 content”** means Audio-Visual Material produced by and supplied to the Licensee by Teilifís na Gaeilge

**“VAT”** means value added tax and each like tax imposed in addition to or in substitution therefor.

## 2. Grant of Licence

2.1 Subject to and conditional upon compliance with the terms and conditions contained herein and in particular subject to the exclusions and restrictions set out in clauses 3 and 4, MCPSI grants the Licensee a non-exclusive licence to do the following during the Term:

- (a) to reproduce Repertoire Works incorporated into Audio-Visual Material on servers within the Territory for the purpose of transmitting such Audio-Visual Material to Cable Subscribers (for their own private and non-commercial use) by means of the Licensed Services; and
- (b) notwithstanding clause 3.2, to extend an existing synchronisation licence which has previously been granted by the copyright owner to reproduce Repertoire Works in RTE content, TG4 content and Sky content only for exploitation in an alternative media to that licensed under this Agreement so that such synchronisation is licensed for the purpose of making available the RTE content, TG4 content and Sky content on the licensed Service.

2.2 Subject to and conditional upon compliance with the terms and conditions contained herein and in particular subject to the exclusions and restrictions set out in clauses 3 and 4, IMRO grants the Licensee a non-exclusive licence, during the Term, to make available to the public (as that term is defined in Section 40 (1) (a) only and to authorise the making available to the public of Repertoire Works incorporated into Audio-Visual Material within the Territory solely as part of and for the purposes of the provision of the Licensed Services.

2.3 The provisions of clauses 3.5, 3.6, 4.1, 4.2, and 4.3 shall not apply to a particular Repertoire Work where the owner of the relevant rights in such

Repertoire Work has granted permission to the Licensee for the use of that Repertoire Work on the Licensed Services in the manner described under the relevant clause on such terms and conditions (including, if required, the payment of royalties or fees in addition to those specified under this Agreement) as the owner thinks fit.

## 3. Exceptions and Limitations

3.1 The licences granted under clause 2 of this Agreement are valid only insofar as:

- (a) the Licensed Services are general entertainment on demand services; and
- (b) the Licensee is the Service Provider in relation to the Licensed Services.

3.2 For the avoidance of doubt, the licences granted under clause 2 of this Agreement shall not authorise the manufacture or distribution of physical products containing Audio-Visual Material, such as (without limitation) the ordering of compact discs, DVDs, or any other type of physical media, but which are distributed by mail.

3.3 For the avoidance of doubt, the licences granted under clause 2 of this Agreement shall not extend to the performing, showing or playing a copy in public (as those terms are used in the Act) of Repertoire Works, whether as part of the Licensed Services or otherwise.

3.4 Unless (i) the relevant Member has expressly consented to such use being covered under the MCPSI licence granted herein, the licence granted under clause 2.1 of this Agreement shall not permit the use of Repertoire Work(s) with any advertising or sponsorship where:

- (a) such Repertoire Work(s) are incorporated into such advertising or sponsorship; or
- (b) such Repertoire Work(s) are otherwise presented in such a way that a reasonable person might associate the Repertoire Work(s) with the advertising or sponsorship.

3.5 For the avoidance of doubt (and without prejudice to the generality of clause 3.4), the licence granted under clause 2.1 of this Agreement shall not apply to any Audio-Visual Material made available for the purpose of

- (a) promoting the branding of the Licensee, any affiliate of the Licensee or any third party; in such a manner that:
  - (i) one or more particular Repertoire Works, composers or writers are associated with such promotion; or
  - (ii) a reasonable person might assume that there was an association between particular Repertoire

Works, composers or writers and such promotion;

excerpt(s) within the definition of Permitted Excerpts; and

3.6 The licence granted under clause 2.1 shall not apply to graphic copies (meaning, without limitation, copies of lyrics, notation or scores) of Repertoire Works. For the avoidance of doubt, the licences granted under these terms and conditions shall not apply to any "karaoke" service.

(ii) neither of the Licensors has notified the Licensee in writing that their Member or the associated society member objects to the reproduction of any such Repertoire Work.

3.7 The licence granted under clause 2.2 shall only apply to a Repertoire Work made available to the public as part of a Licensed Service where the Licensee has the benefit of a valid licence for or a right to make a reproduction of that particular Repertoire Work and for that particular form of exploitation via the Licensed Service either pursuant to these terms and conditions or otherwise. By way of example only, the licence granted by MCPSI under clause 2.1 does not cover the copying of Repertoire Works in an advertisement (see clause 3.5 above). However, clause 3.5 does not apply to the licence granted by IMRO under clause 2.2. Therefore, pursuant to this clause 3.7, the licence granted by IMRO under clause 2.2 would not apply (in the context of this example) unless the Licensee has the benefit of a right to copy the Repertoire Work for use in that advertisement (and on the Licensed Service(s)).

In any event, any licence hereunder only applies to the relevant Repertoire Works and not (by way of example only) to any underlying dramatic or literary work which forms part of the Dramatico-Musical Work or which such Dramatico-Musical Work is based on or uses

3.8 For the avoidance of doubt, this Agreement grants no licence whatsoever in relation to:

4.2 The licences granted under this Agreement shall not extend to or permit any adaptation of any Repertoire Work to be copied or communicated to the public as part of a Licensed Service unless the relevant Member has consented to such adaptation. By way of example only, this applies to:

- (a) Repertoire Works which are made available by the Licensee outside of the Licensed Services; or
- (b) Repertoire Works which are made available by the Licensee outside of a Cable Subscribers Address by way of the Internet, a mobile network or any other wired or wireless network.
- (c) material containing Repertoire Works (other than Audio-Visual Material) that is made available by the Licensee.

- (a) any sampling (meaning the taking of part of the music and/or lyrics of a Repertoire Work and incorporating such part into another Musical Work) or the making available to the public or reproduction in the form of a sample of such part of a Repertoire Work; or
- (b) using with music, lyrics other than those written to be used with the music or authorised for use with the music; or
- (c) using with lyrics, music other than that written to be used with the lyrics or authorised for use with the lyrics.

However, such other exploitation of Repertoire Works may fall within the scope of other licensing schemes operated by the Licensors, details of which shall be made available to the Licensee on request.

#### 4. Further Restrictions

4.1 Where any Repertoire Work forms part of any Dramatico-Musical Work, the licence granted under clause 2.1 shall not apply, in relation to Audio-Visual Material, to the reproduction of:

4.3 The licences granted under this Agreement do not extend to the reproduction of any Commercial Work:

- (a) the whole Dramatico-Musical Work; or
- (b) any excerpt(s) from such Dramatico-Musical Work unless all of the following circumstances apply:
  - (i) that which is copied or made available to the public via the Licensed Services under this Agreement contains only

- (a) in the form of a parody, pastiche or burlesque of any Commercial Work or of any composer or writer of any Commercial Work or any band or other group of artists which includes any composer or writer of any Commercial Work; or
- (b) where there is a derogatory, facetious, obscene or demeaning reference to the Commercial Work, its composer(s) and author(s) or the performing artist; or
- (c) without prejudice to clauses 3.4 and 3.6 above, in any manner which is likely to or causes the public to believe that the Commercial Work (or the composer(s) thereof) is endorsing or promoting any product or service, or the views expressed in Audio-Visual Material.

Whether a use of a Commercial Work breaches this clause 4.3 shall be decided by the Licensors in their reasonable discretion.

4.4 All rights not specifically granted under this Agreement are hereby reserved.

- 4.5 This Agreement only covers Repertoire Works. It does not extend to other rights or interests, including (by way of example only), rights in sound recordings, films, dramatic works, performers' rights or rights in performances. The Licensee is required to obtain the appropriate waivers, consents and/or licences from the person(s) owning or controlling rights in relation to sound recordings containing Repertoire Works or performers of that Repertoire Work.
- 4.6 It is the responsibility of the Licensee to obtain all necessary licences in relation to any Musical Work which is not, or to the extent that it is not, a Repertoire Work, and no licence is granted under this Agreement in relation thereto.
- 4.7 Nothing in this Agreement affects the moral rights of authors of Repertoire Works whether subsisting in Ireland or any other territory.

## 5. Royalty Fees

In consideration of the licence granted under this Agreement, the Licensee shall pay to the Licensors the Royalty Fee calculated as follows:

- 5.1 In respect of the Standard Limited On Demand Streaming Service the Royalty Fee shall be
- (a) €0.047 per Base Subscriber per month: and;
  - (b) €0.047 per Active Subscriber per month.
- 5.2 In respect of the Premium Limited on Demand Streaming Service the Royalty Fee in respect of each piece, or part thereof, of Audio-Visual Material Streamed shall be for the Licence Term the higher of:
- a) 2.5% of the Gross Revenue: and
  - b) €0.04 per piece, or part thereof, of Audio-Visual Material Streamed.

## 6. Fees and Payment

- 6.1 In consideration of the licences and authorisations granted under this Agreement, the Licensee shall pay to the Licensors the Royalty Fees.
- 6.2 The Royalty Fee set out in clause 5 shall be paid to IMRO by Licensee within thirty (30) days of receipt of an invoice
- 6.3 All licence fees and payments referred to in this Agreement are subject to VAT or other equivalent sales tax. The Licensee shall pay to the Licensors VAT or other equivalent sales tax (if applicable) at the rate or rates from time to time in force on any sums payable under this Agreement.
- 6.4 Except as expressly set out in these terms and conditions, no deduction in respect of any tax, or any other deduction or set-off of whatsoever nature, shall be made in calculating or paying any sum due under this Agreement.

- 6.5 Within 15 working days of the end of each Month, the Licensee shall send to the Licensors a fully and accurately completed royalty statement (in the form attached in Schedule 1).

- 6.6 Without prejudice to any other right or remedy of the Licensors, and without imposing an obligation to accept late payment, where any fees payable under this Agreement are not paid by the due date (or the date on which such fees should ordinarily have been paid in circumstances where the Licensors have been unable to submit an invoice) due to default of the Licensee, the Licensee shall (if required by the Licensors) pay interest on such late payment calculated on a daily basis at an annual rate of 3% over the prime overdraft rate, current from time to time, of Bank of Ireland payable from the date on which the payment should have been made to the date on which the payment was made.

- 6.7 All payments made under this Agreement shall be in Euro unless otherwise agreed by the parties in writing. Where it is necessary to convert an amount payable to Euro from another currency, the exchange rate used shall be the Irish Times closing mid market rate on the first working day of the Quarter to which the payment relates. The Licensee shall pay all bank charges on transfers of sums payable by the Licensee to the Licensors

- 6.8 The Licensee shall notify the Licensors promptly of any change in the Licensed Service details.

## 7. Supply of Information

- 7.1 In relation to any and all Audio-Visual Material and made available to the public under this Agreement via all Licensed Services, the Licensee will deliver a fully and accurately completed AV Usage Report to the Licensors or to the Licensors' duly authorised agent (details of which will be provided to the Licensee) within 14 days of the end of each Month throughout the Term.

- 7.2 The Licensee must also supply the Licensors with any further information or documentation in its possession, power, custody or control (and use its reasonable endeavours to supply the Licensors with any further information or documentation not in its possession, power, custody or control) reasonably requested by the Licensors at any time, in order to enable the Licensors to verify the Repertoire Work(s) which have been reproduced or distributed via all Licensed Services.

- 7.3 Where any or all of the Licensed Services are accessible by Cable Subscribers only on payment of subscription or other similar payment (or access is otherwise limited or controlled in some way), the Licensee shall, upon request of the Licensors, use reasonable endeavours to ensure that such Licensed Services are at all times accessible by the Licensors free of charge for the purposes of the Licensors verifying that the Licensee is acting in accordance with this Agreement. For the avoidance of doubt, the Licensee shall not be required to provide free access to the Standard Limited On Demand



Streaming Service” or the “Premium Limited On Demand Streaming Service

- 7.4 The email addresses for delivery of the Music Usage Declaration referred to in clauses 7.1 are;

[david.galligan@imro.ie](mailto:david.galligan@imro.ie)  
[sean.donegan@imro.ie](mailto:sean.donegan@imro.ie)

- 7.5 Without prejudice to any right in law that the Licensors may have to obtain such information, the Licensee shall not be obliged to provide to the Licensors any information which identifies Cable Subscribers or which otherwise constitutes “personal data” as defined in the Data Protection Acts 1988 and 2003. For the avoidance of doubt, the Licensee must still provide all required Music Usage Information (or other information to be provided under this Agreement), but is entitled to remove any element of it which reveals the identity of Cable Subscribers or otherwise causes it to include or constitute “personal data”.

## 8. Auditing

- 8.1 The Licensee shall keep and make available for inspection upon reasonable notice (and shall procure that each relevant party keeps and makes available for inspection upon reasonable notice), both during and for twelve months after termination of this Agreement, proper, detailed books and records relating to (a) use of all Musical Works and (b) any income or other consideration received by or on behalf of the Licensee in consideration for the provision of Licensed Services, together with any supporting documentation relating thereto covering the period up to six years prior to the date of notification of audit.
- 8.2 For the purposes of this clause 8, the Licensee shall allow upon reasonable notice (and shall procure that each relevant party shall allow) access to its premises to inspect relevant accounting records, but not more than once per annum. The duly authorised representatives (who shall be external qualified accountants or auditors unless otherwise agreed between the parties) of the Licensors shall have such access to the Licensee’s premises and shall be entitled to inspect, make extracts and take copies of any of the information and/or documentation available and to carry out such work as is, in their reasonable opinion, considered necessary to verify compliance with this Agreement.
- 8.3 The Licensors shall not (and shall procure that their representatives shall not), without the Licensee’s written consent, disclose to any third party any confidential information of the Licensee (so long as it remains confidential) received in the course of an audit carried out under this clause 8, save that such confidential information may be disclosed to the Licensors’ directors, board sub-committee members officers, employees and professional advisors (solely where such persons are under a duty of confidentiality in relation to information so received and the Licensors shall be liable to the Licensee in respect of any breach of such confidentiality obligation) solely for purposes connected with this Agreement.

- 8.4 For the avoidance of doubt, books, records and accounting records as referred to in clauses 8.1 and 8.2 above shall include data, information and records held on computers.

## 9. Security and Encryption

- 9.1 Unless agreed otherwise, the Licensee will utilise or require the utilisation of an industry security standard which is developed and is available for use in the protection of Repertoire Works. Until such time, the Licensee must use its reasonable endeavours to prevent unauthorised copying and/or the unauthorised issuing of copies of Repertoire Works by whatever technical means are practicable. Upon request the Licensee will inform the Licensors concerning its progress in relation to fulfilling this obligation.

## 10. Termination and Expiry

- 10.1 This Agreement shall expire on 31<sup>st</sup> December 2024.
- 10.2 This Agreement may be terminated by either party by the terminating party giving the other party not less than three calendar months notice in writing.
- 10.3 Each party shall have the right to terminate this Agreement by notice forthwith where the other party:
- (a) commits a material breach of this Agreement which is capable of remedy and fails to remedy such breach within 14 clear days after receipt of notice of such breach; or
  - (b) commits a material breach of this Agreement which is not capable of remedy; or
  - (c) the other goes into receivership or any resolution is passed for its winding-up, examinership or liquidation (other than for the purposes of reconstruction or amalgamation) or is otherwise unable to pay its debts,

and, for the avoidance of doubt, any breach which consists of a failure by either party to perform an obligation under this Agreement within any period required or by any date specified under this Agreement shall be deemed to be capable of remedy if such obligation is performed by such party within the 14 day remedy period specified in this Clause 10.3.

## 11. No Assignment

- 11.1 The licences granted under this Agreement are personal to the Licensee and the Licensee may not assign, sub-license or otherwise transfer any or all of its rights or obligations under this Agreement without the written agreement of both IMRO and MCPSI.

## 12. Miscellaneous

- 12.1 No delay or omission in exercising any right or remedy hereunder shall operate as a waiver thereof or of any other right or remedy and no single or partial exercise thereof shall preclude any other or further exercise thereof or the exercise of any other rights or remedies. No waiver shall be binding or effectual for any purpose unless expressed in writing and signed by the party giving it and any such waiver shall be effective only in the specific instance and for the purpose given.
- 12.2 This Agreement sets forth the entire agreement of the parties in relation to the subject matter hereof and each of the parties hereto acknowledges that it has not entered into this Agreement in reliance on any representation or term not contained in this Agreement. This Agreement shall not be modified or varied except by a written instrument signed by the parties hereto.
- 12.3 The headings to the clauses in this Agreement are included for ease of reference only and are not part of this Agreement and are not to be taken into account in its construction.
- 12.4 The parties shall (and shall procure that any other necessary party within its control shall) execute all such documents and do all such acts and things as may be reasonably be required on or subsequent to completion of this Agreement for securing each of the obligations of the respective parties under this Agreement.
- 12.5 If this Agreement creates any rights which would in the absence of this provision be enforceable by any person not a party to this Agreement, such rights shall not be enforceable.
- 12.6 This Agreement shall be construed according to the laws of Ireland and the parties agree to submit to the jurisdiction of the Irish Courts.

## SCHEDULE 1

### Form of Accounting Statement

Licensee name:

Licensee Contact name:

Monthly Reporting:

Month Ending:

Name of Licensed Services: Premium Limited On Demand Streaming Service / Standard Limited on Demand Streaming Service

**Premium Limited On Demand Streaming Service**  
**Details for the Month**

Total Gross Revenue for the Month (exclusive of VAT):

Total number of individual pieces of Audio-Visual material or part thereof) Streamed per Cable Subscriber in the Month:

Total number of individual pieces of Audio-Visual material or part thereof) purchased per Cable Subscriber in the Month:

**Standard Limited On Demand Streaming Service**  
**Details for the Month**

Total Subscribers in Month:

- Base Subscribers:
- Active Subscribers:

**Declared to be a true and accurate return**

**Signed on behalf of Licensee**

---

**Date supplied:**

Please e-mail completed forms, within 15 days after the end of each month, to:  
sean.donegan@imro.ie and David.galligan@imro.ie

## SCHEDULE 2

### AV Usage Report

1. The Licensee shall supply to IMRO lists identifying, to the reasonable satisfaction of IMRO and in a form acceptable to IMRO, details of Audio-Visual Material and all On Demand Events.
2. The lists to be supplied under paragraph 3 shall be supplied to IMRO within four weeks of the On Demand Event in question.
3. The Licensee is required to provide electronic only reports from the commencement date of this agreement and are required to provide details of all On Demand Events in the form set out below.

#### **(a) Standard Limited On Demand Streaming Service**

The details provided should include:

- Unique Identifier assigned to the production by the reporting company where these are provided in the metadata to Licensee (For example TV3, RTÉ and TG4)
- Production title
- Episode name
- Series name if provided to Licensee by a third party as part of metadata
- Year of production if provided to by a third party as part of metadata
- Number of times streamed

The details for advertisements should include

- Advertisement title
- Unique Identifier/ Clock Number
- Duration
- Source information
- Number of times streamed

#### **(b) Premium Limited on Demand Streaming Service**

The details provided should include:

- Production titles,
- Year of production if provided to Licensee by a third party as part of metadata
- Number of pieces, or part thereof, of Audio-Visual Material streamed
- Gross Revenue received per On Demand Event

On Demand events may be returned using an electronic report generated by the Licensees On Demand TV system provided that it meets with IMRO's approval.

4. The Parties shall discuss the provisions of additional reporting requirements that IMRO may require during the Term of this Agreement. Any variations to the AV Usage Report in this Schedule 2 must be agreed in writing by the Parties and signed by duly authorised representatives of both Parties.

# VINYL COPY CODE LICENCE APPLICATION FORM



	Licensee Details	Billing Details (if different)
Company Name		
Contact Name		
Email address		
Address		
Telephone Number		
MCPS Account Number		

Total Music Usage					
License Band	Band A	Band B	Band C	Band D	Band E
Annual Fee (excluding VAT)	€150	€300	€750	€1,150	€1,500
Album Download (maximum number of downloads per annum)	430	857	2,140	3,220	4,277
License Required	<input type="checkbox"/>	<input type="checkbox"/>	<input type="checkbox"/>	<input type="checkbox"/>	<input type="checkbox"/>

Please refer to the full Terms and Conditions for full scheme details and definitions.

By signing this Application For Licence form you are confirming the following:

- The information contained in this document is accurate to the best of your knowledge
- You accept and agree to be bound by the Terms and Conditions

Signed:

Date:

Please note that no licence, whether express or implied, shall be taken to have been granted by MCPS, IMRO or their members merely by the completion and / or submission of this application form. Such a licence shall only be deemed to be granted upon payment of invoice to the licensor.

## VINYL COPY CODE STANDARD TERMS AND CONDITIONS

### 1. Definitions

**"the Act"** means the Copyright and Related Rights Act 2000, as amended from time to time.

**"Agreement"** means these terms and conditions, the schedules to these terms and conditions and the AFL completed and submitted online by the Licensee.

**"Application for Licence" or "AFL"** means the online application form with which the Licensee applies for a licence under this Agreement.

**"Commencement Date"** means the start date of the licences granted under this Agreement required by the Licensee and set out in the AFL.

**"Commercial Work"** means each Musical Work the copyright in which is owned or controlled in the Republic of Ireland by MCPSI (or an MCPS member or an affiliated society or an affiliated society member) but excluding:

- (a) Production Music Works; and
- (b) a Commissioned Work, PROVIDED THAT for the purposes of clause 4.3, a Commissioned Work shall not be excluded from such definition where the commissioning agreement does not authorise the Licensee to use the Commissioned Work in the context set out in those clauses.

**"Commissioned Work"** means a Musical Work specially and expressly commissioned by the Licensee from composer/writer members of IMRO and/or MCPS.

**"Data Storage Device"** means any medium on which data can be stored (whether temporarily or permanently) whether existing now or invented in the future.

**"Device"** means a portable or static electronic communications device which is capable of allowing Users to communicate with each other via wire and/or wireless networks.

**"Dramatico-Musical Work"** means any ballet, opera, operetta, musical, musical play or work of a similar nature.

**"Excluded Service"** means any service (or the relevant part of a service) which falls within the scope (from time to time) of any of the following MCPSI/IMRO licensing schemes:

- (a) MCPSI – Karaoke and MIDI scheme;
- (b) MCPSI – Music-on-hold scheme;
- (c) MCPSI & IMRO – Music Services B2B;
- (d) MCPSI – Premium Telephone Line Services scheme;
- (e) IMRO – Premium Telephone Line Services scheme;
- (f) MCPSI & IMRO Joint Ringback scheme;
- (g) MCPSI & IMRO B2B Music Preview scheme.

**"Gross Revenue"** shall have the meaning set out in the Online Music Licence. A full text of the Online Music

Licence is available from IMRO website at [www.imro.ie](http://www.imro.ie). Broadly, Gross Revenue means all revenue received (or receivable) by the Licensee from Users in consideration of the provision of the Licensed Services and all other revenue received (or receivable) by the Licensee as a result of the provision of the Licensed Services such as, without limitation, advertising and sponsorship fees. For the avoidance of doubt, this is by way of a summary only. The definition of Gross Revenue applicable to this Agreement is the definition set out in the Online Music Licence.

**"IMRO"** means Irish Music Rights Organisation CLG whose registered office is at Copyright House, Pembroke Row, Lower Baggot Street, Dublin 2., contracting for and on behalf of itself and for and on behalf of and as agents of its various affiliated societies.

**"Karaoke Version"** means Musical Works which are offered in the form of "karaoke" so that the lyrics of the Musical Work appear graphically onscreen as the music plays (but, for the avoidance of doubt, cannot be printed in physical form) or reproduced in any form where the music is not playing.

**"Licensed Service(s)"** means the service(s) set out in the AFL.

**"Licensee"** means the party that submits an AFL and is granted a licence by the Licensors.

**"Licensors"** means IMRO and MCPSI.

**"MCPS"** means Mechanical-Copyright Protection Society Limited whose registered office is at 2 Pancras Square, London N1C 4AG, contracting for and on behalf of itself and for and on behalf of and as agents of its various Members and affiliated societies.

**"MCPSI"** means mechanical Copyright Protection Society (Ireland) Limited whose registered office is at Copyright House, Pembroke Row, Lower Baggot Street, Dublin 2, Republic of Ireland contracting for and on behalf of and as agents of MCPSI its various Members and affiliated societies.

**"Member"** means:

- (a) in the case of MCPS, each person, firm or company who or which, from time to time, has appointed MCPS as agent in relation to online exploitation either before or during the Term, other than where such person, firm or company has opted not to participate in the licensing scheme pursuant to which this Agreement has been entered into, PROVIDED THAT a member who has so appointed MCPSI after the commencement of the Term shall only be regarded as a member for the purposes of this Agreement with effect from the date on which the Member so appointed MCPS; and
- (b) in the case of IMRO, any person, firm or company who or which, from time to time, pursuant to the Articles of Association of IMRO has been admitted either before or during the Term as a member of IMRO, PROVIDED THAT a member who has been so admitted after the commencement of the Term shall only be regarded as a member for the purposes of this Agreement with effect from the date of admission into IMRO.

**"Music Download Service"** means a service (or the relevant part of a service), other than an Excluded Service or a Music Download Karaoke Service, offering Permanent Downloads.

**"Music Download Karaoke Service"** means a service (or the relevant part of a service), other than an Excluded Service, offering Permanent Downloads in the form of Karaoke Versions.

**"Musical Work"** means any musical work (as defined in the Act) and any lyrics or words, including in graphical form in respect of Karaoke Service only, written to be used with such musical work (if applicable). It includes any part of such a work.

**"Music Usage Declaration"** means the information referred to in clause 6.1, to be provided in the form set out at Schedule 1.

**"Network"** means the internet, a mobile network or any other wired or wireless network.

**"Online Music Licence"** means a licence agreement under the Licensors' online music licensing scheme known as the "Online Music Licence" as published by the Licensors from time to time.

**"Permanent Download"** means the communication to the public of any one Musical Work whereby such Musical Work may be retained by the User on a permanent basis. For the avoidance of doubt, the communication to the public for retention by the User on a permanent basis of ten (10) Musical Works shall be treated as ten (10) separate Downloads.

**"Permitted Service"** means, subject always to the limits as set out in AFL, a Music Download Service which offers audio-only Permanent Downloads of Musical Works to Users on a free to consumer basis. Upon purchasing a vinyl release directly from the Licensee during the Term, Users shall receive a redeemable code that may be used on the Permitted Service to purchase an identical digital copy of the vinyl release.

**"Repertoire Work"** means each Musical Work the relevant copyright in which is owned or controlled, from time to time, in the UK by:

- (a) MCPSI or a member of MCPS or a Member of an associated society or an associated society member PROVIDED THAT (i) if one or more of those who own or control the copyright in a relevant Repertoire Work is not MCPSI or a Member or an associated society or associated society member, the expression "Repertoire Work" shall only apply to such interest in the Repertoire Work as is owned or controlled by MCPSI or the associated society or the relevant Member or associated society member, and (ii) it shall exclude any Musical Works that a Member of MCPSI or an associated society has withdrawn or withheld from this Agreement; and
- (b) IMRO or a Member or an associated society or an associated society member PROVIDED THAT if one or more of those who own or control the copyright in a relevant Repertoire Work is not IMRO or a Member or an associated society or associated society member, the expression "Repertoire Work" shall only apply to such interest in the Repertoire Work as is owned or controlled by IMRO or the associated society or the relevant member or associated society member;

The Licensors shall have the right to exclude specific Repertoire Works from the licences granted under this Agreement by giving notice in writing (which may be by email) to the Licensee. Such notice shall take effect two working after it is sent. The Licensee will promptly remove such Repertoire Works from the Licensed Service (unless the relevant rights have been validly licensed from an alternative source).

For the avoidance of doubt, if a Musical Work is a Repertoire Work in relation to one Licensor and not the other then it remains a Repertoire Work under this Agreement in relation only to the licence granted by that Licensor.

**"Royalty Fees"** means the royalties applicable to the Licensed Service as set out in Schedule 1 and payable in accordance with the terms of clause 5.

**"Server Territory"** means the European Economic Area, Switzerland, the United States of America, Canada and such other territories as may be agreed in writing by the parties.

**"Service Provider"** means, the party which, in relation to a Music Service, most closely meets the following criteria:

- (a) contracts with the User in relation to the provision of the Licensed Service;
- (b) sets and controls the price the User pays;
- (c) can fully report on all elements of Gross Revenue (including relevant advertising revenues);
- (d) can fully report on all elements of music usage (or can procure such reporting);
- (e) controls how content is offered and bundled within the Licensed Service; and
- (f) carries out or authorises, on their instruction, the carrying out of the copyright restricted acts licensed under this Agreement.

**"Term"** means 12 months from the Commencement Date unless expiring or terminated earlier in accordance with clause 5 or clause 10.

**"Territory"** means Ireland and such other countries as the Licensors and the Licensee may agree in writing.

**"User"** means a natural person in the Territory who receives the Licensed Services for their own private and non-commercial use.

**"VAT"** means value added tax and each like tax imposed in addition to or in substitution there for.

## **2. Grant of Licence**

- 2.1 Subject to and conditional upon compliance with the terms and conditions contained herein and in particular subject to the exclusions and restrictions set out in clauses 3 and 4, MCPSI grants the

Licensee a non-exclusive licence to do the following during the Term:

- (a) to reproduce Repertoire Works on servers within the Server Territory for the purpose of transmitting the same to Users (for the User's own private and non-commercial use) by means of the Licensed Services; and
- (b) where the Licensed Services expressly authorise the temporary or permanent reproduction of Repertoire Works on Users' Data Storage Devices, to cause such copies to be made in the Territory for the User's own private and non-commercial use.

2.2 Subject to and conditional upon compliance with the terms and conditions contained herein and in particular subject to the exclusions and restrictions set out in clauses 3 and 4, IMRO grants the Licensee a non-exclusive licence, during the Term to communicate to the public (as that term is defined in the Act) and to authorise the communication to the public of Repertoire Works within the Territory solely as part of and for the purposes of the provision of the Licensed Services.

### 3. Exceptions and Limitations

3.1 The licences granted under clause 2 of this Agreement are valid only insofar as:

- (a) the Licensed Services are Permitted Services; and
- (b) the Licensee is the Service Provider in relation to the Licensed Services.

3.2 For the avoidance of doubt, the licences granted under clause 2 of this Agreement shall not authorise the manufacture or distribution of physical products containing Repertoire Works, such as (without limitation) the ordering of compact discs (or any other type of physical media) via a Licensed Service, but which are distributed by mail.

3.3 The licences granted under clause 2 of this Agreement shall not extend to the public performance (as that term is used in the Act) of Repertoire Works, whether as part of the Licensed Services or otherwise.

3.4 Unless (i) the relevant Member has expressly consented to such use being covered under the MCPSI licence granted herein, (ii) the Licensee has entered into an agreement with the relevant Member to this effect and (iii) evidence of such agreement has been provided to the Licensors, the licence granted under clause 2.1 of this Agreement shall not permit the use of Repertoire Work(s) with any advertising or sponsorship where:

- (a) such Repertoire Work(s) are incorporated into such advertising or sponsorship; or
- (b) such Repertoire Work(s) are otherwise presented in such a way that a reasonable person might associate the Repertoire Work(s) with the advertising or sponsorship.

3.5 Unless (i) the relevant Member has expressly consented to such use being covered under the MCPSI licence granted herein, (ii) the Licensee has entered into an agreement with the relevant Member

to this effect and (iii) evidence of such agreement has been provided to the Licensors, for the avoidance of doubt (and without prejudice to the generality of clause 3.4), the licences granted under these terms and conditions shall not apply to any Repertoire Work(s) made available for the purpose of (whether in whole or in part):

- (a) directly or indirectly encouraging the User to purchase or obtain goods or services of whatsoever nature (other than music via the Licensed Service); or
- (b) promoting the branding of the Licensee, any affiliate of the Licensee or any third party; in such a manner that:

- (i) one or more particular Repertoire Works, composers or writers are associated with such promotion; or
- (ii) a reasonable person might assume that there was an association between particular Repertoire Works, composers or writers and such promotion;

3.6 The licence granted under clause 2.1 shall not apply to graphic copies (meaning, without limitation, copies of lyrics, notation or scores) of Repertoire Works.

3.7 The licence granted under clause 2.2 shall only apply to a Repertoire Work communicated to the public as part of a Licensed Service where the Licensee has the benefit of a valid licence for or a right to make a reproduction of that particular Repertoire Work and for that particular form of exploitation via the Licensed Service either pursuant to these terms and conditions or otherwise. By way of example only, the licence granted by MCPSI under clause 2.1 does not cover the copying of Repertoire Works in an advertisement (save in certain specified circumstances, see clause 3.4 above). However, a parallel restriction does not apply to the licence granted by IMRO under clause 2.2. The licence granted by IMRO under clause 2.2 would not apply (in the context of this example) unless the Licensee, pursuant to clause 3.4, has the benefit of a right to copy the Repertoire Work for use in that advertisement (and on the Licensed Service(s)).

3.8 For the avoidance of doubt, this Agreement grants no licence whatsoever in relation to Repertoire Works which are made available by the Licensee outside of the Licensed Service. However, such other exploitation of Repertoire Works may fall within the scope of other licensing schemes operated by the Licensors, details of which shall be made available to the Licensee on request.

### 4. Further Restrictions

4.1 Where any Repertoire Work forms part of any Dramatico-Musical Work, the licence granted under clause 2.1 shall not apply to the reproduction of the whole or substantially the whole Dramatico-Musical Work unless:

- (a) the Licensee has specifically notified the Licensors that it wishes to reproduce the whole or substantially the whole work; and



- (b) the Licensors have notified the Licensee that all relevant Members consent to such reproduction.

For the purposes of this clause 4.1, the expression "Dramatico-Musical Work" shall include any version of such work (with or without cuts, additions, interpolations or the like) which has been publicly performed. Furthermore, for the avoidance of doubt, substantially the whole work shall be deemed to be reproduced where all or nearly all the individual songs or other music included in the work are reproduced.

- 4.2 In any event, any licence hereunder only applies to the relevant Repertoire Works and not (by way of example only) to any underlying dramatic or literary work which forms part of the Dramatico-Musical Work or which such Dramatico-Musical Work is based on or uses.
- 4.3 The licences granted under this Agreement shall not extend to or permit any adaptation of any Repertoire Work to be copied or communicated to the public as part of a Licensed Service unless the relevant Member has consented to such adaptation. By way of example only, this applies to:
  - (a) any sampling (meaning the taking of part of the music and/or lyrics of a Repertoire Work and incorporating such part into another Musical Work) or the communication to the public or reproduction in the form of a sample of such part of a Repertoire Work; or
  - (b) using with music lyrics other than those written to be used with the music or authorised for use with the music; or
  - (c) using with lyrics music other than that written to be used with the lyrics or authorised for use with the lyrics.

However, subject always to clause 4.9 and provided that such alterations do not amount to an adaptation of a Repertoire Work and do not contravene clause 4.3 then this Agreement shall apply in relation to Repertoire Works that have been modified (including music and/or lyrics) for the purpose of satisfying the requirements of the relevant recording.

- 4.4 The licences granted under this Agreement shall not extend to:
  - (a) the reproduction or communication to the public of any Commercial Work or part thereof in the form of a parody or burlesque of any Commercial Work or of any composer or writer of any Commercial Work or any band or other group of artists which includes any composer or writer of any Commercial Work; or
  - (b) the use of any Commercial Work in any context which the Licensee ought reasonably to consider as being likely to be insulting or detrimental to the composer featured on the commercially released sound recording of the music or the relevant Member or associated society member.
- 4.5 Any additional limitations in relation to Associated Societies' rights to grant the licences set out in clause 2 of this Agreement which have been notified to the Licensors shall be notified to the Licensee in writing (which may include by email)

and shall be binding no less than 10 days following such notice. Where any restriction of a material or adverse nature is added, the Licensee shall have the right to terminate this Agreement by giving written notice to the Licensors.

- 4.6 All rights not specifically granted under this Agreement are hereby reserved.
- 4.7 This Agreement only covers Repertoire Works. It does not extend to other rights or interests, including (by way of example only), rights in sound recordings, films, dramatic works, performers' rights or rights in performances. The Licensee is required to obtain the appropriate waivers, consents and/or licences from the person(s) owning or controlling rights in relation to sound recordings containing Repertoire Works or performers of that Repertoire Work.
- 4.8 It is the responsibility of the Licensee to obtain all necessary licences in relation to any Musical Work which is not, or to the extent that it is not, a Repertoire Work, and no licence is granted under this Agreement in relation thereto.
- 4.9 Nothing in this Agreement affects the moral rights of authors of Repertoire Works whether subsisting in the UK or any other territory.

## **5. Fees and Payment**

- 5.1 In consideration of the licences and authorisations granted under this Agreement, the Licensee shall pay to the Licensors the Royalty Fees in advance.
- 5.2 The Royalty Fees shall be payable within 21 days of receipt of the Licensors' invoice by debit/credit card, bank transfer or, where agreed otherwise, by cheque. For the avoidance of doubt, this Agreement shall not come into force until the Licensee has paid the Royalty Fees.
- 5.3 The Licensee may at any time during the Term change from a lower band to a higher band by paying the difference between the lower band Royalty Fee already paid and the higher band Royalty Fee. The Licensee may not change from a higher band to a lower band and the Licensors shall not refund the Licensee in the event that the Licensee's actual exploitation of Repertoire Works is such that the Licensee would be eligible for a lower band Royalty Fee but has paid the Royalty Fee for a higher band.
- 5.4 The Licensee shall notify the Licensors immediately if the maximum usage limits in Band E in any one Licensed Service are exceeded. Such limits shall be pro-rated in respect of any licence period which is less than 12 months. If the maximum usage limits are exceeded, this Agreement shall terminate and the Licensee shall contact the Licensors to discuss the appropriate licence applicable to the Licensee.
- 5.5 The Licensee shall notify the Licensors immediately if the Licensee's usage of any of the Licensed Services exceeds the amount stated in the Licensee's AFL, so that the amount the Licensee pays as Royalty Fees may be adjusted accordingly.

- 5.6 The Licensee shall notify the Licensors promptly of any material change in the information provided in the AFL and the effective date of such change.
- 5.7 All Royalty Fees and payments referred to in this Agreement are subject to VAT or other equivalent sales tax. The Licensee shall pay to the Licensors VAT or other equivalent sales tax (if applicable) at the rate or rates from time to time in force on any sums payable under this Agreement.
- 5.8 Except as expressly set out in these terms and conditions, no deduction in respect of any tax, or any other deduction or set-off of whatsoever nature, shall be made in calculating or paying any sum due under this Agreement.

## 6. Supply of Information

- 6.1 In relation to any and all Repertoire Works, reproduced and communicated to the public under this Agreement via all Licensed Services, the Licensee will deliver a fully and accurately completed Music Usage Declaration to the Licensors or to the Licensors' duly authorised agent (details of which will be provided to the Licensee) within 14 days of the end of each 12 month licence period.
- 6.2 The Licensee must also supply the Licensors with an MCPSI Claim ID and any further information or documentation in its possession, power, custody or control (and use its reasonable endeavours to supply the Licensors with any further information or documentation not in its possession, power, custody or control) reasonably requested by the Licensors at any time, in order to enable the Licensors to verify the Repertoire Work(s) which have been reproduced or distributed via all Licensed Services.
- 6.3 The email address for delivery of the Music Usage Declaration is [onlinelicensing@imro.ie](mailto:onlinelicensing@imro.ie)
- 6.4 Without prejudice to any right in law that the Licensors may have to obtain such information, the Licensee shall not be obliged to provide to the Licensors any information which identifies Users or which otherwise constitutes "personal data" as defined in the Data Protection Act 1998. For the avoidance of doubt, the Licensee must still provide all required Music Usage Declaration (or other information to be provided under this Agreement), but is entitled to remove any element of it which reveals the identity of Users or otherwise causes it to include or constitute "personal data".

## 7. Credits and Notices

- 7.1 The Licensee shall include on each of the Licensed Services:
  - (a) the logo of *IMRO*; and
  - (b) details of the following website and, where practical, hypertext links to it: [www.imro.ie](http://www.imro.ie)

Approval of the Licensors shall be deemed to be given to the positioning of the above credits and notices within the terms and conditions of the Licensed Service(s) where it is not reasonably practical to position such information elsewhere.

## 8. Auditing

- 8.1 The Licensee shall keep and make available for inspection upon reasonable notice (and shall procure that each relevant party keeps and makes available for inspection upon reasonable notice), both during and for twelve months after termination of this Agreement, proper, detailed books and records relating to (a) use of all Musical Works and (b) any income or other consideration received by or on behalf of the Licensee in relation to the Licensed Services, together with any supporting documentation relating thereto covering the period up to six years prior to the date of notification of audit. Where any agreement between the Licensee and the Licensors replaces this Agreement or licenses substantially the same activities (the "**Replacement Agreement**"), the twelve month time-limit referred to above shall begin following termination or expiry of the Replacement Agreement.
- 8.2 For the purposes of this clause 8, the Licensee shall allow upon reasonable notice (and shall procure that each relevant party shall allow) access to its premises to inspect relevant accounting records, but not more than once per annum. The duly authorised representatives (who shall be external qualified accountants or auditors unless otherwise agreed between the parties) of the Licensors shall have such access to the Licensee's premises and shall be entitled to inspect, make extracts and take copies of any of the information and/or documentation available and to carry out such work as is, in their reasonable opinion, considered necessary to verify compliance with this Agreement.
- 8.3 If tests under any audit and verification process indicate under-payment of the correct Royalty Fee during the period under audit, then, without prejudice to the Licensors' other rights under this Agreement, the Licensee shall pay the amount of the underpayment plus interest based on the period from which the correct fee should have been paid to the Licensors to the date when it was actually paid.
- 8.4 If any audit and verification process discloses (a) under-payment of more than 7.5% of the correct Royalty Fee during the period under audit and/or (b) failures to report correctly (so as to affect a distribution by the Licensors to their Members) amounting to at least 7.5% of the music usage during the period under audit, then, without prejudice to the Licensors' other rights under this Agreement, the Licensee shall pay, in addition to the payment referred to in clause 8.3, the Licensors' reasonable costs of such audit and verification within 28 days of receipt of the Licensors' VAT invoice therefor.
- 8.5 The Licensors shall not (and shall procure that their representatives shall not), without the Licensee's written consent, disclose to any third party any confidential information of the Licensee (so long as it remains confidential) received in the course of an audit carried out under this clause 8, save that such confidential information may be disclosed to the Licensors' directors, board sub-committee members officers, employees and professional advisors (solely where such persons are under a duty of confidentiality in relation to information so received and the Licensors shall be liable to the Licensee in respect of any breach of such

confidentiality obligation) solely for purposes connected with this Agreement.

- 8.6 For the avoidance of doubt, books, records and accounting records as referred to in clauses 8.1 and 8.2 above shall include data, information and records held on computers.

## 9. Security and Encryption

Unless agreed otherwise, the Licensee will utilise or require the utilisation of an industry security standard which is developed and is available for use in the protection of Repertoire Works. Until such time, the Licensee must use its reasonable endeavours to prevent unauthorised copying and/or the unauthorised issuing of copies of Repertoire Works by whatever technical means are practicable. Upon request the Licensee will inform the Licensors concerning its progress in relation to fulfilling this obligation.

## 10. Termination and Expiry

- 10.1 This Agreement shall expire on expiry of the Term unless terminated earlier by written agreement or in accordance with the terms of this clause 10

- 10.2 This Agreement may be terminated by the Licensee, by giving not less than three months written notice to the Licensors or upon written notice in circumstances where the Licensee is ceasing to engage in activities covered by this Agreement.

- 10.3 A party shall have the right to terminate this Agreement by notice forthwith where the other party:

- (a) commits a material breach of this Agreement which is capable of remedy and fails to remedy such breach within 14 clear days after receipt of notice of such breach; or
- (b) commits a material breach of this Agreement which is not capable of remedy; or
- (c) goes into receivership or any resolution is passed for its winding-up or liquidation (other than for the purposes of reconstruction or amalgamation) or is otherwise unable to pay its debts,

and, for the avoidance of doubt, any breach which consists of a failure by either party to perform an obligation under this Agreement within any period required or by any date specified under this Agreement shall be deemed to be capable of remedy

if such obligation is performed by such party within the 14 day cure period specified in clause 10.3(a) above.

## 11. No Assignment

The licences granted under this Agreement are personal to the Licensee and the Licensee may not assign, sub-license or otherwise transfer any or all of its rights or obligations under this Agreement without the prior written agreement of both MCPSI and IMRO.

## 12. Miscellaneous

- 12.1 No delay or omission in exercising any right or remedy hereunder shall operate as a waiver thereof or of any other right or remedy and no single or partial exercise thereof shall preclude any other or further exercise thereof or the exercise of any other rights or remedies. No waiver shall be binding or effectual for any purpose unless expressed in writing and signed by the party giving it and any such waiver shall be effective only in the specific instance and for the purpose given.

- 12.2 This Agreement sets forth the entire agreement of the parties in relation to the subject matter hereof and each of the parties hereto acknowledges that it has not entered into this Agreement in reliance on any representation or term not contained in this Agreement. This Agreement shall not be modified or varied except by a written instrument signed by the parties hereto.

- 12.3 The headings to the clauses in this Agreement are included for ease of reference only and are not part of this Agreement and are not to be taken into account in its construction.

- 12.4 The parties shall (and shall procure that any other necessary party within its control shall) execute all such documents and do all such acts and things as may be reasonably be required on or subsequent to completion of this Agreement for securing each of the obligations of the respective parties under this Agreement.

- 12.5 If this Agreement creates any rights which would in the absence of this provision be enforceable by any person not a party to this Agreement, such rights shall not be enforceable.

- 12.6 This Agreement shall be construed according to the laws of Ireland and the parties agree to submit to the jurisdiction of the Irish Courts.

**SCHEDULE 1  
MUSIC USAGE DECLARATION FORM**

To be completed within 14 days of the end of each 12 month licence period

<b>Licence Number</b>	
<b>Company Name</b>	
<b>Contact Name</b>	
<b>Contact Email Address</b>	
<b>Contact Address</b>	
<b>Telephone Number</b>	
<b>MCPSI Claim ID</b>	

<b>Music Usage Details (for the end of each 12 month licence period)</b>		
<b>Music Download</b>	Number of Download Codes Redeemed:	
<b>Licensed Service</b>	Website URL:	

COVER SHEET

**IMRO/MCPSI**  
**SHORT TERM JOINT GENERAL**  
**ENTERTAINMENT**  
**ONLINE LICENCE**  
**(Subscription Video on Demand Version)**

NAME OF LICENSEE	[ ] ("the Licensee")
COMPANY REGISTRATION NUMBER	[ ]
REGISTERED ADDRESS OF LICENSEE	[ ]
LICENSED SERVICE	[insert description of licensed service] ("the Licensed Service")
COMMENCEMENT DATE	[ ] ("the Commencement Date")
QUARTERLY ADVANCE	[ ] ("the Quarterly Advance")
ROYALTY FEE	The higher of:  (a) 2.5% of the Applicable Revenue; and  (b) Per subscriber monthly minimum royalties ("Minimum Royalties"), to be agreed with the Licensed Service.  ("the Royalty Fee")
<b>SPECIAL CONDITIONS*:</b>  *For the avoidance of doubt, any special conditions included in this section, override the attached terms and conditions to the extent there is any conflict.	

Signed on behalf of the Licensee:

\_\_\_\_\_

Date: \_\_\_\_\_

**Signed on behalf of the Mechanical-Copyright Protection Society Ireland Limited ("MCPSI") of Copyright House, Pembroke Row, off Lower Baggot Street, Dublin 2, D02 HW59 contracting for and as agent on behalf of MCPS and for and on behalf of and as agent of the various members and affiliated Societies of MCPS:  
:**

\_\_\_\_\_ **Date:** \_\_\_\_\_

**Signed on behalf of the Irish Music Rights Organisation CLG ("IMRO") of Copyright House, Pembroke Row, off Lower Baggot Street, Dublin 2, D02 HW59 contracting on behalf of itself and for and on behalf of and as agents of its affiliated societies:**

\_\_\_\_\_ **Date:** \_\_\_\_\_

**IMRO/ MCPSI**  
**SHORT TERM GENERAL ENTERTAINMENT ONLINE LICENCE**  
**(Subscription Video on Demand Version)**

**TERMS AND CONDITIONS**

**1. Definitions**

**"the Act"** means the Copyright and Related Rights Act 2000, as amended from time to time.

**"Agreement"** means these terms and conditions, the Cover Sheet and the AFL completed and signed by the Licensee and signed by the Licensors.

**"Applicable Revenue"** means the Gross Revenue less VAT (or other equivalent sales tax, as applicable).

**"Application for Licence" or "AFL"** means the IMRO and MCPSI General Entertainment Online Licence application form.

**"Audio-Visual Material"** means any specific presentation of Musical Works in conjunction with images, whether moving or still. For the avoidance of doubt (but without prejudice to the express restrictions contained in this Agreement), the following shall not be treated as Audio-Visual Material for the purpose of this Agreement:

- (a) the fact that ordinary web pages (or equivalent) are visible to the User while the User is listening to music; or
- (b) the fact that the media player used to play the music generates random visual images while the music is playing;

provided, in both cases, that the User would not reasonably be expected to associate the Repertoire Works being played with the images presented or think that there is any deliberate association by the Licensee of the Repertoire Works with such images.

**"Broadcast Service"** means a service (or the relevant part of a service) by which Content is broadcast (as that term is defined in the Broadcasting Act 2009) to Users via a Network, including simulcasts of a broadcast service. For the avoidance of doubt, to constitute a Broadcast Service, there must be no interactive functionality, for example (without limitation), no use of controls that enable the User to pause, skip, move forward or backwards through the stream or personalise in any way the content made available in the stream.

**"Commercial Work"** means each Musical Work the copyright in which is owned or controlled in Ireland by MCPSI (or an MCPS member or an

affiliated society or an affiliated society member) but excluding:

- (a) Production Music Works; and
- (b) a Commissioned Work, PROVIDED THAT for the purposes of clauses 3.2 and 4.3, a Commissioned Work shall not be excluded from such definition where the commissioning agreement does not authorise the Licensee to use the Commissioned Work in the context set out in those clauses.

**"Commissioned Work"** means a Musical Work specially and expressly commissioned by the Licensee from composer/writer members of IMRO and/or MCPS.

**"Content"** means, unless stated otherwise in the cover sheet to this Agreement, Audio-Visual Material other than (a) content licensable under General Entertainment On Demand (Download to Own and Rental version) Joint Online Music Licence, Joint Podcasting Scheme or the Limited Online Exploitation Licence, (b) Karaoke Content or (c) content consisting of an audio-visual ringtone (or so-called "vid-tone").

**"Content Usage Declaration"** means the information set out in the Licensors' reporting format attached to this Agreement as Appendix 2.

**"Cover Sheet"** means the cover sheet to this Agreement detailing, among other things, the Licensee details and the Licensed Services covered by this Agreement.

**"Data Storage Device"** means any medium on which data can be stored (whether temporarily or permanently) whether existing now or invented in the future.

**"Download"** means the making available to the public of Content, whereby such Content may be retained by the User on a temporary or permanent basis.

**"Dramatico-Musical Work"** means any ballet, opera, operetta, musical, musical play or work of a similar nature.

**"Generic Promotions"** means any item of Content the purpose of which is to promote or advertise the Licensee, the Licensed Service (or specific Content made available on the Licensed Service) and/or any other service of the

Licensee, including but not limited to an item of Content which merely features the logo and/or image and/or words associated with the Licensee or a 'channel' forming part of the Licensed Service (sometimes known otherwise as an 'ident'), but excluding all Trailers.

**"GEOL Service"** means a Permanent Download Service, LD/ODS Service or Premium and Interactive Webcasting Service.

**"Gross Revenue"** shall have the meaning set out in Appendix 1.

**"Karaoke Content"** means content consisting of a karaoke recording; i.e a recording of a Repertoire Work where the lyrics are reproduced graphically as music plays and which is specifically designed for members of the general public to sign the Repertoire Work as the music plays.

**"Licensed Service(s)"** means the service(s) set out on the Cover Sheet.

**"Licensors"** means IMRO and MCPSI.

**"Limited Download / On Demand Streaming Service (LD/ODS)"** means a service (or the relevant part of a service) whereby a User may receive Content by streaming on-demand via a Network (where the time and place at which such Content is received is selected by the User) and/or may download via a Network that Content but where such download may not be retained by the User on a permanent basis.

**"MCPS"** means Mechanical-Copyright Protection Society Limited whose registered office is at 2 Pancras Square, London, N1C 4AG, contracting for and on behalf of itself and for and on behalf of agents of its various Members and affiliated societies.

**"Member"** means:

- (a) in the case of MCPS, each person, firm or company who or which, from time to time, has appointed MCPS as agent in relation to online exploitation either before or during the Term, PROVIDED THAT a member who has so appointed MCPS after the commencement of the Term shall only be regarded as a member for the purposes of this Agreement with effect from the date on which the Member so appointed MCPS; and
- (b) in the case of IMRO, any person, firm or company who or which, from time to time, pursuant to the Articles of Association of IMRO has been admitted either before or during the Term as a member of IMRO, PROVIDED THAT a member who has been so admitted after the commencement of the Term shall only be regarded as a member for the purposes of this Agreement with effect from the date of admission into IMRO.

**"Musical Work"** means any musical work (as defined in the Act) and any lyrics or words written to be used with such musical work (if applicable). It includes any part of such a work.

**"Network"** means the internet, a mobile network or any other wired or wireless network.

**"Permitted Excerpts"** refers only to Dramatico-Musical Works and means excerpts where the use of all such excerpts in any Content complies with all the following limitations:

- (a) the total duration of the excerpts does not exceed 20 minutes;
- (b) the use is not a "potted version" of the Dramatico-Musical Work;
- (c) the use is not or does not cover a complete act of the Dramatico-Musical Work;
- (d) each excerpt is not presented in a "dramatic form" as defined below; and
- (e) as regards ballets specifically devised for television or excerpts from existing ballets, the total duration does not exceed five minutes.

A dramatic form shall be deemed to be created only by a performance in which there is a distinct plot depicted by actors and where the story of the Dramatico-Musical Work and/or its associated words is woven into and carries forward the plot and its accompanying action (a dramatic form shall not, for example, be deemed to be created by the use of costume, scenery, and/or any dance routine merely to provide an acceptable presentation of the work). For the purposes of this paragraph the word "actors" shall include actors, singers, mimics and/or puppets.

**"PMSR"** means any production music sound recording being a sound recording (as opposed to a Musical Work) the copyright in which is owned or controlled in Ireland by MCPSI (or an MCPS Member or an associated society or an associated society member) and where such party has authorised MCPS to license such recordings as so-called production or library music.

**"Premium and Interactive Webcasting Service"** means a service (or the relevant part of a service) by which Content is communicated to the public via a Network and:

- (a) no permanent or temporary copy of any Musical Work is retained by the User; and
- (b) such service is neither a Broadcast Service, a Permanent Download Service or a LD/ODS Service.



**"Production Music"** means Production Music Works and PMSRs.

**"Production Music Work"** means any Musical Work:

- (a) embodied on a PMSR; and
- (b) the copyright in which is owned or controlled in Ireland by MCPS (or an MCPS Member or an associated society or an associated society member).

**"Quarter"** means each of the periods from 1st January to 31st March, 1st April to 30th June, 1st July to 30th September, and 1st October to 31st December, throughout the Term.

**"Quarterly Advance"** means the sum set out in the Cover Sheet, excluding VAT (or other equivalent sales tax, as applicable).

**"Repertoire Work"** means:

- (a) in relation to the licence granted by MCPSI, Commercial Works, Production Music Works and PMSRs, but excludes (i) any musical work forming part of a Dramatico-Musical Work and (ii) Commissioned Music; and
- (b) in relation to the licence granted by IMRO, each Musical Work the relevant copyright in which is owned or controlled, from time to time, in Ireland by IMRO or a Member or an associated society or an associated society member PROVIDED THAT if one or more of those who own or control the copyright in a relevant Repertoire Work is not IMRO or a Member or an associated society or associated society member, the expression "Repertoire Work" shall only apply to such interest in the Repertoire Work as is owned or controlled by IMRO or the associated society or the relevant member or associated society member.

For the avoidance of doubt, if a Musical Work is a Repertoire Work in relation to one Licensor and not the other then it remains a Repertoire Work under this Agreement in relation only to the licence granted by that Licensor.

**"Royalty Fees"** means the royalties payable, as set out in Cover Sheet.

**"Server Territory"** means the European Economic Area, Switzerland, the United States of America, Canada and such other territories as may be agreed in writing by the parties.

**"Service Provider"** means, the party which, in relation to a Licensed Service, most closely meets the following criteria:

- (a) contracts with the User in relation to the provision of the Licensed Service;
- (b) sets and controls the price the User pays;
- (c) can fully report on all elements of the gross revenue (including relevant advertising revenues) of the Licensed Service;
- (d) can fully report on all elements of music usage (or can procure such reporting);
- (e) controls how content is offered and bundled within the Licensed Service; and
- (f) carries out or authorises, on their instruction, the carrying out of the copyright restricted acts licensed under this Agreement.

**"Term"** means the period starting on the Commencement Date and ending upon the date set out in clause 13.1 (unless terminated earlier under clauses 13.2 or 13.3).

**"Territory"** means Ireland

**"Trailer"** means an item of Content which is either:

- (a) the official film or television trailer produced and released by the producer of the relevant item of Content; or
- (b) an unedited clip of up to 90 seconds duration of the relevant item of Content being made available on the Licensed Service.

**"User"** means a natural person in the Territory who receives the Licensed Services for their own private and non-commercial use.

**"VAT"** means value added tax and each like tax imposed in addition to or in substitution therefor.

## 2. Grant of Licence

2.1 Subject to and conditional upon compliance with the terms and conditions contained herein and in particular subject to the exclusions and restrictions set out in clauses 3 and 4, MCPSI grants the Licensee a non-exclusive licence to do the following during the Term:

- (a) to reproduce Repertoire Works incorporated into Content on servers within the Server Territory for the purpose of communicating to the public such Content to Users (for the User's own private and non-

commercial use) by means of the Licensed Services; and

- (b) where the Licensed Services expressly authorise the temporary or permanent reproduction of Content on Users' Data Storage Devices, to cause copies of Repertoire Works incorporated into Content to be made in the Territory for the User's own private and non-commercial use; and
- (c) to make available to the public (as that term is defined in Section 40 (1) (a) only and to authorise the making available to the public of PMSRs incorporated into Content within the Territory solely as part of and for the purposes of the provision of the Licensed Services; and
- (d) notwithstanding clause 3.2, to extend an existing synchronisation licence which has previously been granted by the copyright owner to reproduce Repertoire Works in Content for exploitation in an alternative media to that licensed under this Agreement so that such synchronisation is licensed for the purpose of making available the Content on the Licensed Service.

2.2 Subject to and conditional upon compliance with the terms and conditions contained herein and in particular subject to the exclusions and restrictions set out in clauses 3 and 4, IMRO grants the Licensee a non-exclusive licence, during the Term, to make available to the public (as that term is defined in Section 40 (1) (a) only within the Territory and to authorise the making available to the public within the Territory of Repertoire Works incorporated into Content solely as part of and for the purposes of the provision of the Licensed Services.

2.3 The provisions of clauses 3.5, 3.6, 4.1, 4.2, and 4.3 shall not apply to a particular Repertoire Work where the owner of the relevant rights in such Repertoire Work has granted permission to the original producer of the Content for the use of that Repertoire Work in the Content in the manner described under the relevant clause on such terms and conditions (including, if required, the payment of royalties or fees in addition to those specified under this Agreement) as the owner thinks fit.

2.4 The licence granted under clause 2.1 above shall not apply to Commercial Works included in Generic Promotions.

### 3. Exceptions and Limitations

3.1 The licences granted under clause 2 of this Agreement are valid only insofar as:

- (a) the Licensed Services are GEOL Services; and
- (b) the Licensee is the Service Provider in relation to the Licensed Services.

For the avoidance of doubt content which is made available to the public in form of paid for a la carte download to-own- or paid for rental on demand streaming shall not be licensed under this Agreement

3.2 For the avoidance of doubt, this Agreement does not grant any "synchronisation licence" covering the initial fixation of Repertoire Works in combination with visual images to create and produce Content.

3.3 For the avoidance of doubt, the licences granted under clause 2 of this Agreement shall not authorise the manufacture or distribution of physical products containing Content, such as (without limitation) the ordering of compact discs (or any other type of physical media), but which are distributed by mail.

3.4 For the avoidance of doubt, the licences granted under clause 2 of this Agreement shall not extend to the performing, sharing or playing of a copy (as that term is used in the Act) of Repertoire Works, whether as part of the Licensed Services or otherwise.

3.5 Unless (i) the relevant Member has expressly consented to such use being covered under the MCPSI licence granted herein, (ii) the Licensee has entered into an agreement with the relevant Member to this effect and (iii) evidence of such agreement has been provided to the Licensors, the licence granted under clause 2.1 of this Agreement shall not permit the use of Repertoire Work(s) with any advertising or sponsorship where:

- (a) such Repertoire Work(s) are incorporated into such advertising or sponsorship; or
- (b) such Repertoire Work(s) are otherwise presented in such a way that a reasonable person might associate the Repertoire Work(s) with the advertising or sponsorship.

3.6 Unless (i) the relevant Member has expressly consented to such use being covered under the MCPSI licence granted herein, (ii) the Licensee has entered into

an agreement with the relevant Member to this effect and (iii) evidence of such agreement has been provided to the Licensors, for the avoidance of doubt (and without prejudice to the generality of clause 3.5), the licence granted under clause 2.1 of this Agreement shall not apply to any Content made available for the purpose of (whether in whole or in part):

- (a) directly or indirectly encouraging the User to purchase or obtain goods or services of whatsoever nature; or
- (b) promoting the branding of the Licensee, any affiliate of the Licensee or any third party in such a manner that:
  - (i) one or more particular Repertoire Works, composers or writers are associated with such promotion; or
  - (ii) a reasonable person might assume that there was an association between particular Repertoire Works, composers or writers and such promotion;

3.7 The licence granted under clause 2.1 shall not apply to graphic copies (meaning, without limitation, copies of lyrics, notation or scores) of Repertoire Works. For the avoidance of doubt, the licences granted under these terms and conditions shall not apply to any "karaoke" service.

3.8 The licence granted under clause 2.2 shall only apply to a Repertoire Work made available to the public as part of a Licensed Service where the Licensee has the benefit of a valid licence for or a right to make a reproduction of that particular form of exploitation via the Licensed Service either pursuant to these terms and conditions or otherwise. By way of example only, the licence granted by MCPSI under clause 2.1 does not cover the copyright of Repertoire works in an advertisement (see clause 3.5 above). However, clause 3.5 does not apply to the licence granted by IMRO under clause 2.2. Therefore, pursuant to this clause 3.8, the licence granted by IMRO under clause 2.2 would not apply (in the context of this example) unless the Licensee has the benefit of a right to copy the Repertoire Work for use in that advertisement (and on the Licensed Service (s)).

#### **4. Further Restrictions**

4.1 Where any Repertoire Work forms part of any Dramatico-Musical Work, the licence

granted under clause 2.1 shall not apply, in relation to Content, to the reproduction of:

- (a) the whole Dramatico-Musical Work; or
- (b) any excerpt(s) from such Dramatico-Musical Work unless all of the following circumstances apply:
  - (i) that which is copied or communicated to the public via the Licensed Services under this Agreement contains only excerpt(s) within the definition of Permitted Excerpts; and
  - (ii) neither of the Licensors has notified the Licensee in writing that their Member or the associated society member objects to the reproduction of any such Repertoire Work.

In any event, any licence hereunder only applies to the relevant Repertoire Works and not (by way of example only) to any underlying dramatic or literary work which forms part of the Dramatico-Musical Work or which such Dramatico-Musical Work is based on or uses.

4.2 The licences granted under this Agreement shall not extend to or permit any adaptation of any Repertoire Work to be copied or communicated to the public as part of a Licensed Service unless the relevant Member has consented to such adaptation. By way of example only, this applies to:

- (a) any sampling (meaning the taking of part of the music and/or lyrics of a Repertoire Work and incorporating such part into another Musical Work) or the communication to the public or reproduction in the form of a sample of such part of a Repertoire Work; or
- (b) using with music lyrics other than those written to be used with the music or authorised for use with the music; or
- (c) using with lyrics music other than that written to be used with the lyrics or authorised for use with the lyrics.

4.3 The licences granted under this Agreement do not extend to the reproduction of any Commercial Work:

- (a) where the Content is of an overtly political, sexual, violent or religious nature; or

- (b) in the form of a parody, pastiche or burlesque of any Commercial Work or of any composer or writer of any Commercial Work or any band or other group of artists which includes any composer or writer of any Commercial Work; or
- (c) where there is a derogatory, facetious, obscene or demeaning reference to the Commercial Work, its composer(s) and author(s) or the performing artist; or
- (d) without prejudice to clauses 3.5 and 3.6 above, in any manner which is likely to or causes the public to believe that the Commercial Work (or the composer(s) thereof) is endorsing or promoting any product or service, or the views expressed in the Content; or
- (e) where the making available of the Content constitutes a criminal offence under the laws of Ireland.

Whether a use of a Commercial Work breaches this clause 4.3 shall be decided by the Licensors in their reasonable discretion.

- 4.4 All rights not specifically granted under this Agreement are hereby reserved.
- 4.5 This Agreement only covers Repertoire Works. It does not extend to other rights or interests, including (by way of example only), rights in sound recordings other than PMSRs, films, dramatic works, performers' rights or rights in performances. The Licensee is required to obtain the appropriate waivers, consents and/or licences from the person(s) owning or controlling rights in relation to sound recordings containing Repertoire Works or performers of that Repertoire Work.
- 4.6 It is the responsibility of the Licensee to obtain all necessary licences in relation to any Musical Work which is not, or to the extent that it is not, a Repertoire Work, and no licence is granted under this Agreement in relation thereto.
- 4.7 Nothing in this Agreement affects the moral rights of authors of Repertoire Works whether subsisting in Ireland or any other territory.

## **5. Fees and Payment**

- 5.1 In consideration of the licences and authorisations granted under this Agreement, the Licensee shall pay to the Licensors:
  - (a) the Quarterly Advance; and

(b) subject to clause 5.2, the Royalty Fees.

- 5.2 The Quarterly Advance is recoupable against the Royalty Fees. If any part of the Quarterly Advance remains unrecouped at the end of a Quarter, such unrecouped amount may be carried over to subsequent Quarters, but for the avoidance of doubt, shall not (except as set out in clause 5.3 below) have the effect of reducing any subsequent Quarterly Advance. If any part remains unrecouped upon termination or expiry of the Agreement, the Licensors shall return such part to the Licensee.
- 5.3 The Quarterly advance shall be reviewed by the Licensors at the end of each calendar year. It may also be reviewed by the Licensors during a calendar year if the royalties calculated for any particular Quarter differ from the Quarterly Advance by 20% or more.
- 5.4 Where, in relation to any particular Quarter, the Licensee fails to provide by the required date the information required under the Agreement to allow the calculation referred to in clause 5.1(b), then the Licensors shall be entitled to fix the Royalty Fee based on (a) the Royalty Fees payable in previous Quarters and (b) any other relevant factors which could reasonably lead the Licensors to believe that the Royalty Fees payable would be materially different to those paid or payable in previous Quarters.
- 5.5 The Quarterly Advance shall be payable by direct debit on the first day of each Quarter. Where the Agreement begins (and/or a Licensed Service comes into operation) within a Quarter, the first Quarterly Advance payment shall be pro-rated (according to the Commencement Date) and shall be payable upon the later of signature of this Agreement and the date on which the first Licensed Service is made available to Users for the first time.
- 5.6 Upon receipt of the Content Usage Declaration from the Licensee pursuant to clause 6.1 below, IMRO shall, on behalf of the Licensors, each of the Members, raise an invoice for the due amount, and the Licensee shall pay such invoice by electronic bank transfer (or, if agreed by the Licensee, direct debit) within 21 days of the invoice date.
- 5.7 All licence fees and payments referred to in this Agreement are subject to VAT or other equivalent sales tax. The Licensee shall pay to the Licensors VAT or other equivalent sales tax (if applicable) at the

rate or rates from time to time in force on any sums payable under this Agreement.

5.8 Except as expressly set out in these terms and conditions, no deduction in respect of any tax, or any other deduction or set-off of whatsoever nature, shall be made in calculating or paying any sum due under this Agreement.

5.9 Without prejudice to any other right or remedy of the Licensors, and without imposing an obligation to accept late payment, where any fees payable under this Agreement are not paid by the due date (or the date on which such fees should ordinarily have been paid in circumstances where the Licensors have been unable to submit an invoice) due to default of the Licensee, the Licensee shall (if required by the Licensors) pay interest on such late payment calculated on a daily basis at an annual rate of 3% over the prime overdraft rate, current from time to time, of Bank of Ireland payable from the date on which the payment should have been made to the date on which the payment was made.

5.10 All payments made under this Agreement shall be in Euro unless otherwise agreed by the parties in writing. Where it is necessary to convert an amount payable to Euro from another currency, the exchange rate used shall be the Irish Times closing mid market rate on the first working day of the Quarter to which the payment relates. The Licensee shall pay all bank charges on transfers of sums payable by the Licensee to the Licensors.

5.11 The Licensee shall notify the Licensors promptly of any change in the Licensed Service details provided in the Application for Licence (or set out on the Cover Sheet) and the effective date of such change. If the Licensee wishes to launch an additional Licensed Service, it shall not be licensed under this Agreement until the parties have agreed an appropriate increase to the Royalty Fees.

## **6. Supply of Information**

6.1 In relation to any and all Content reproduced and communicated to the public under this Agreement via the Licensed Services, the Licensee will deliver a fully and accurately completed Content Usage Declaration to the Licensors or to the Licensors' duly authorised agent (details of which will be provided to the Licensee) within 14 days of the end of each Quarter throughout the Term.

6.2 The Licensee must also supply the Licensors with any further information or documentation in its possession, power, custody or control (and use its reasonable endeavours to supply the Licensors with any further information or documentation not in its possession, power, custody or control) reasonably requested by the Licensors at any time, in order to enable the Licensors to verify the Repertoire Work(s) which have been reproduced or distributed via all Licensed Services.

6.3 Where any or all of the Licensed Services are accessible by Users only on payment of subscription or other similar payment (or access is otherwise limited or controlled in some way), the Licensee shall upon request of the Licensors, use reasonable endeavours to ensure that such Licensed Services are at all times accessibly by the Licensors free of charge for the purposes of the Licensors verifying that the Licensee is acting in accordance with this Agreement. For the avoidance of doubt, the Licensee shall not be required to provide free access to a mobile phone network or internet access.

6.3 The email address for delivery of the Content Usage Declaration referred to in clauses 6.1 is [onlinelicensing@imro.ie](mailto:onlinelicensing@imro.ie)

6.4 Without prejudice to any right in law that the Licensors may have to obtain such information, the Licensee shall not be obliged to provide to the Licensors any information which identifies Users or which otherwise constitutes "personal data" as defined in the Data Protection (Amendment) Acts 2003. For the avoidance of doubt, the Licensee must still provide all required information in the Content Usage Declaration (or other information to be provided under this Agreement), but is entitled to remove any element of it which reveals the identity of Users or otherwise causes it to include or constitute "personal data".

## **7. Late Reporting**

7.1 The following provision applies where the Licensee has:

(a) failed to deliver prior to the required date the Usage Declaration for the Licensed Service; or

(b) delivered such Content Usage Declaration prior to the required date, but it contains any omission or error of whatsoever nature (by way of example only, Content having been omitted therefrom or incorrectly or misleadingly named, or the duration of

any Content having been under-reported) which is material and the Licensee has failed to give notice in writing to the Licensors correcting the omission or error by the date upon which such reporting should have been provided.

7.2 In such circumstances (and without prejudice to any other rights which either or both Licensors may have against the Licensee) if one or both of the Licensors has distributed some (or all) royalties received (excluding any commission) to Members and/or Associated Societies based on the usage data supplied, but, as a result of clause 7.1(a) or (b) applying, the royalties distributed do not accurately or fairly represent that which each of the Members and/or Associated Societies should have received (when considering the true usage of Content), then the Licensee shall pay the fees set out in clauses 7.3 and 7.4 (in addition to those set out in clause 5).

7.3 Where clause 7.2 applies, separately in relation to each relevant item of Content either omitted from the relevant Content Usage Declaration or as regards which there was a material omission or error of whatsoever nature or in relation to which the relevant Content Usage Declaration was not delivered, the additional fees shall be calculated at the rate equivalent to that which has been or will be paid by MCPSI and/or IMRO (as applicable) to their members (or associated societies) in relation to the Content Usage Declaration which was submitted prior to the required date.

7.4 Where clause 7.2 applies, the Licensee will also pay interest on the additional fees as referred to in clause 7.3 above computed in accordance with clause 5.9 and calculated from the date on which MCPSI and/or IMRO (as applicable) first made a distribution to their members (or associated societies) in relation to the relevant period to the date on which the Content Usage Declaration was received by the Licensors or the date on which the Licensors received written notice of the relevant error, as the case may be.

7.5 The provisions of this clause apply notwithstanding any other provision of this Agreement, but are without prejudice to any other right which MCPSI and IMRO have in relation to any failure to submit Content Usage Declaration fully or accurately completed within the time stipulated in clause 6.1.

## 8. Bundling

Unless specified in the Cover Sheet the licences granted in this Agreement do not apply to the bundling of Content with other content, goods or services.

## 9. Credits and Notices

9.1 The Licensee shall include on each of the Licensed Services:

- (a) the logo of *IMRO and MCPSI*; and
- (b) details of the following website and, where practical, hypertext links to it: <http://www.imro.ie>

Approval of the Licensors shall be deemed to be given to the positioning of the above credits and notices within the terms and conditions of the Licensed Service(s) where it is not reasonably practical to position such information elsewhere.

## 10. Auditing

10.1 The Licensee shall keep and make available for inspection upon reasonable notice (and shall procure that each Relevant Party keeps and makes available for inspection upon reasonable notice), both during and for twelve months after termination or expiry of this Agreement, proper, detailed books and records relating to (a) the use of all Content and (b) any income or other consideration received by or on behalf of the Licensee in relation to the Licensed Services, together with any supporting documentation relating thereto covering the period up to six years prior to the date of notification of audit. Where any agreement between the Licensee and the Licensors replaces this Agreement or licenses substantially the same activities (the "**Replacement Agreement**"), the twelve month time-limit referred to above shall begin following termination or expiry of the Replacement Agreement.

10.2 For the purposes of this clause 10, the Licensee shall allow upon reasonable notice (and shall procure that each relevant party shall allow) access to its premises to inspect relevant accounting records, but not more than once per annum. The duly authorised representatives (who shall be external qualified accountants or auditors unless otherwise agreed between the parties) of the Licensors shall have such access to the Licensee's premises and shall be entitled to inspect, make extracts and take copies of any of the information and/or documentation available and to carry out such work as is, in their reasonable opinion, considered necessary to verify compliance with the provisions of this Agreement.

- 10.3 If tests under any audit and verification process indicate under-payment of the correct Royalty Fee during the period under audit, then, without prejudice to the Licensors' other rights under this Agreement, the Licensee shall pay the amount of the underpayment plus interest based on the period from which the correct fee should have been paid to the Licensors to the date when it was actually paid (at the rate set out in clause 5.9).
- 10.4 If any audit and verification process discloses (a) under-payment of more than 7.5% of the correct Royalty Fee during the period under audit and/or (b) failures to report correctly (so as to affect a distribution by the Licensors to their Members) amounting to at least 7.5% of the Content usage during the period under audit, then, without prejudice to the Licensors' other rights under this Agreement, the Licensee shall pay, in addition to the payment referred to in clause 11.3, the Licensors' reasonable costs of such audit and verification within 28 days of receipt of the Licensors' VAT invoice therefore.
- 10.5 If tests under any audit and verification process indicate over-payment of the correct Royalty Fee during the period under audit, then the Licensors shall, as soon as is reasonably practical, pay the amount of the overpayment back to the Licensee (but, for the avoidance of doubt, no interest shall be payable unless the overpayment is a result of an act or omission of the Licensors (in which case interest shall be payable at the rate set out in clause 5.9)). However, where the overpayment does not result from an act or omission of the Licensors and the Licensors have already distributed such overpayment to their Members and/or Associated Societies, the Licensors shall be entitled to deduct its reasonable internal and/or external costs in administering the payment back of the overpayment.
- 10.6 The Licensors shall not (and shall procure that their representatives shall not), without the Licensee's written consent, disclose to any third party any confidential information of the Licensee (so long as it remains confidential) received in the course of an audit carried out under this clause 11, save that such confidential information may be disclosed to the Licensors' directors, board sub-committee members, officers, employees and professional advisors (solely where such persons are under a duty of confidentiality in relation to information so received and the Licensors shall be liable to the Licensee in respect of any breach of such confidentiality obligation) solely for purposes connected with this Agreement.
- 10.7 For the avoidance of doubt, books, records and accounting records as referred to in clauses 10.1 and 10.2 above shall include data, information and records held on computers.
- 11. Security and Encryption**
- 11.1 Unless agreed otherwise, the Licensee will utilise or require the utilisation of an industry security standard which is developed and is available for use in the protection of Repertoire Works. Until such time, the Licensee must use its reasonable endeavours to prevent unauthorised copying and/or the unauthorised issuing of copies of Repertoire Works by whatever technical means are practicable. Upon request the Licensee will inform the Licensors concerning its progress in relation to fulfilling this obligation.
- 12. Termination and Expiry**
- 12.1 This Agreement shall expire on **31st December 2023** (or such other date as may be stated on the Cover Sheet) unless terminated earlier in accordance with the terms of this clause 13.
- 12.2 This Agreement may be terminated by the Licensee, by giving not less than three months written notice to the Licensors or upon written notice in circumstances where the Licensee is ceasing to engage in activities covered by this Agreement.
- 12.3 Each party shall have the right to terminate this Agreement by notice forthwith where the other party:
- (a) commits a material breach of this Agreement which is capable of remedy and fails to remedy such breach within 14 clear days after receipt of notice of such breach; or
  - (b) commits a material breach of this Agreement which is not capable of remedy; or
  - (c) the other goes into receivership or any resolution is passed for its winding-up or liquidation (other than for the purposes of reconstruction or amalgamation) or is otherwise unable to pay its debts,
- and, for the avoidance of doubt, any breach which consists of a failure by either party to perform an obligation under this Agreement within any period required or by any date specified under this Agreement shall be

deemed to be capable of remedy if such obligation is performed by such party within the 14 day remedy period specified in clause 13.3(a) above.

### **13. No Assignment**

13.1 The licences granted under this Agreement are personal to the Licensee and the Licensee may not assign, sub-license or otherwise transfer any or all of its rights or obligations under this Agreement without the written agreement of both MCPSI and IMRO.

### **14. Miscellaneous**

14.1 No delay or omission in exercising any right or remedy hereunder shall operate as a waiver thereof or of any other right or remedy and no single or partial exercise thereof shall preclude any other or further exercise thereof or the exercise of any other rights or remedies. No waiver shall be binding or effectual for any purpose unless expressed in writing and signed by the party giving it and any such waiver shall be effective only in the specific instance and for the purpose given.

14.2 This Agreement sets forth the entire agreement of the parties in relation to the subject matter hereof and each of the

parties hereto acknowledges that it has not entered into this Agreement in reliance on any representation or term not contained in this Agreement. This Agreement shall not be modified or varied except by a written instrument signed by the parties hereto.

14.3 The headings to the clauses in this Agreement are included for ease of reference only and are not part of this Agreement and are not to be taken into account in its construction.

14.4 The parties shall (and shall procure that any other necessary party within its control shall) execute all such documents and do all such acts and things as may be reasonably be required on or subsequent to completion of this Agreement for securing each of the obligations of the respective parties under this Agreement.

14.5 If this Agreement creates any rights which would in the absence of this provision be enforceable by any person not a party to this Agreement, such rights shall not be enforceable.

14.6 This Agreement shall be construed according to the laws of Ireland and the parties agree to submit to the jurisdiction of the Irish Courts.



# Appendix 1

## Gross Revenue Definition

### Definitions

**"Gross Revenue"** means, subject to the provisions of this Appendix 1:

- (a) all revenue received (or receivable) by the Licensee from Users in consideration for the provision of the Licensed Services; and
- (b) all revenue, including by way of sponsorship and commissions, received (or receivable) by the Licensee as a result of the inclusion of third party advertising "in-stream" or "in-download" as part of the Licensed Service, being advertising placed immediately at the start, end or during the actual delivery (by way of streaming or downloading as applicable) of Content to a User; and
- (c) all revenue, including by way of sponsorship, click-throughs and other commissions, received (or receivable) by the Licensee as a result of the placement of third party advertising, buy or click-through buttons on a Relevant Page (as defined below) of the Licensed Service (and including any page which directly follows such Relevant Page leading up to and including the downloading or streaming of the Content offering);

and in each of the above cases such revenue shall, for the avoidance of doubt, include any such revenue whether received or receivable by the Licensee or any associate, affiliate, agent or representative of such party.

Subject to the remainder of this Appendix 1, there shall be no other deduction or set-off from the above revenues other than reasonable refunds to Users for services that they were unable to use (but had paid for) due to technical faults in the Licensed Services.

**"Relevant Page"** means a page:

- (a) from which Licensed Services are "actually offered" to Users. A Licensed Service is "actually offered" to Users from a page if Content is enabled or made directly available from that Licensed Service to the User to download or stream from that page (in most cases this will be where such Content can be purchased by the User or their download or stream otherwise takes place); but only
- (b) where such offering forms all or the predominant part of that page, being for the purposes of this Agreement where the offering comprises 75% or more of the

space on that page excluding space occupied by any advertising. For the purposes of performing the foregoing calculation, the "offering" shall include any content which directly relates to the actual offering of the Licensed Service pursuant to sub-paragraph (a) above (by way of example, but without limitation, an image of the artist or artwork closely associated with the offering, reviews of the offering, credits, and media player controls).

### 1. General

- (a) The Licensors' experience of the "Relevant Page" concept is that it does not always work in practice. As a result, the Licensors reserve the right to discuss with the Licensee an alternative construct for ensuring that appropriate revenue is accounted to the Licensors and that it can be accounted accurately. Any agreed alternative construct shall be set out in the special conditions on the Cover Sheet. If the parties are unable to agree on such alternative construct, the Licensors reserve the right to apply the dispute resolution procedure referred to in paragraph 2(d) below.
- (b) For the avoidance of doubt, the definition of Gross Revenue above shall be applied in conjunction with the provisions on bundling set out in clause 8 of the terms and conditions. The Licensors confirm that no revenue which is included in Gross Revenue under this Agreement shall form any part of the "revenue base" under any other licence or licensing scheme operated by the Licensors (or either of them) which grants all or some of the rights set out in clauses 2.1 and 2.2 of the terms and conditions (albeit in relation to a service which is not a Licensed Service hereunder).
- (c) For the further avoidance of doubt, revenue which relates solely to services other than the Licensed Service shall not be included in the Gross Revenue.
- (d) For the further avoidance of doubt, Gross Revenue shall not be reduced by credit card commissions or similar payment process charges.

### 2. Advertising and Sponsorship Revenue

- (a) Gross Revenue obtained in the form of advertising or sponsorship revenue shall be reduced by any commission amount that has been deducted only by external third party advertising agencies (not being in any

way affiliated to the Licensee) used to sell advertising on behalf of the Licensee, subject the maximum deduction being 15%.

- (b) For the avoidance of doubt, advertising revenue referred to in sub-paragraph (c) of the definition of Gross Revenue above shall not include revenue arising from sponsored searches or click-through commissions arising from such searches.
- (c) The provisions of paragraph 2(d) below shall apply if a dispute (a "Dispute") arises in relation to the application of the provisions of this Appendix 1 as to what revenue is included within the definition of Gross Revenue.
- (d) Provided that the Licensors and the Licensee shall have held substantive negotiations in good faith regarding the subject matter of the Dispute over a period of at least 21 days from the date on which the Licensors notify the Licensee or the Licensee notifies the Licensor (as the case may be) in writing of the existence of such Dispute, the Licensors or the Licensee shall then be entitled by notice in writing from the Licensors to the Licensee or by the Licensee to the Licensors to refer the Dispute for determination to an independent online adjudicator acting as an expert. The identity of such expert shall either be agreed or, in the absence of such agreement within 7 days of the written notice of referral, shall be determined by the President for the time being of the Institute of Chartered Accountants, and shall be an independent chartered accountant, unless the Licensors and the Licensee agree that another type of expert would be more suitable to determine such Dispute. The Licensors and the Licensee will seek to agree the procedure for the conduct of any expert determination. If such agreement is not reached within 7 days of the appointment of the expert, the expert shall have power to set the procedure for the expert determination. The expert shall be required, in particular, to take into account any part of the UK Copyright Tribunal's decision in Reference 84-90/05 relevant to the Dispute in reaching his decision. The expert shall make his determination as soon as reasonably practicable. The expert shall have power to award costs in the expert's determination, unless the Licensors and the Licensee agree otherwise. The decision of the expert is final and binds the parties to the Dispute unless there is manifest error, wilful default or fraud. For the avoidance of doubt, it is hereby confirmed that the expert shall have no jurisdiction to amend any term of the Agreement.

## ***Appendix 2***

### **Reporting**

Licensee shall provide to Licensor the following reports within 30 days of the end each quarter:

- (a) the number of paying and free trial subscribers to the Licensed Service in the Territory and the Applicable Revenue attributable to such subscribers (the "**Financial Report**");
- (b) a statement of all titles streamed on the Licensed Service in the Territory within that calendar quarter setting out: (i) the film or television programme title; (ii) the television series title and episode title; (iii) the EIDR or Unique Identifier number; (iv) the Licensee identifier number; and (v) the total number of streams per title (vi) Country of Origin confirmation. (the "**Music Usage Report**").

The details for advertisements should include (i) Advertisement Title (ii) Unique Identifier / Clock Number (iii) Duration (iv) Source Information (v) Number of times streamed.

The Financial Reports and Music Usage Reports shall together be referred to as the "**Reports**".

The parties may discuss the provisions of additional reporting requirements that IMRO may require during the Term of this Agreement.

**COVER SHEET**

**IMRO/MCPSI  
JOINT GENERAL ENTERTAINMENT  
ONLINE LICENCE**

**(Download-To-Own and On Demand Rental Version)**

NAME OF LICENSEE	[ ] ("the Licensee")
COMPANY REGISTRATION NUMBER	[ ]
REGISTERED ADDRESS OF LICENSEE	[ ]
LICENSED SERVICE	[insert description of licensed service] ("the Licensed Service")
COMMENCEMENT DATE	[ ] ("the Commencement Date")
QUARTERLY ADVANCE	[ ] ("the Quarterly Advance")
ROYALTY FEE	<p>The higher of:</p> <ul style="list-style-type: none"><li>(a) 2.5% of the Applicable Revenue; and</li><li>(b) the following minimum royalties ("<b>Minimum Royalties</b>"), as applicable:<ul style="list-style-type: none"><li>(i) € 0.12 in respect of each item of film content (film content being full length feature films and other audiovisual content similar to feature films made for television broadcast or online transmission) purchased and/or downloaded as a Permanent Download;</li><li>(ii) € 0.04 in respect of each item of Content other than film content purchased and/or downloaded as a Permanent Download;</li><li>(iii) € 0.04 in respect of each item of film content streamed (or cached for later viewing) and/or purchased by a User from an On Demand Rental Service;</li><li>(iv) € 0.01 in respect of each item of Content other than film content streamed (or cached for later viewing) and/or purchased by a User from an On Demand Rental Service.</li></ul></li></ul>

	(“the Royalty Fee”)
--	---------------------

**SPECIAL CONDITIONS\*:**

\*For the avoidance of doubt, any special conditions included in this section, override the attached terms and conditions to the extent there is any conflict.

**Signed on behalf of the Licensee:**

\_\_\_\_\_ **Date:** \_\_\_\_\_

**Signed on behalf of the Mechanical-Copyright Protection Society Ireland Limited (“MCPSI”) of Copyright House, Pembroke Row, off Lower Baggot Street, Dublin 2 contracting for and as agent on behalf of MCPS and for and on behalf of and as agent of the various members and affiliated Societies of MCPS:**

:

\_\_\_\_\_ **Date:** \_\_\_\_\_

**Signed on behalf of the IRISH MUSIC RIGHTS ORGANISATION CLG (“IMRO”) of Copyright House, Pembroke Row, off Lower Baggot Street, Dublin 2, contracting on behalf of itself and for and on behalf of and as agents of its affiliated societies:**

\_\_\_\_\_ **Date:** \_\_\_\_\_

**IMRO/ MCPSI**  
**GENERAL ENTERTAINMENT ONLINE LICENCE**  
**(Download-To-Own and On Demand Rental Version)**

**TERMS AND CONDITIONS**

**1. Definitions**

**"the Act"** means the Copyright and Related Rights Act 2000, as amended from time to time.

**"Agreement"** means these terms and conditions, the Cover Sheet and the AFL completed and signed by the Licensee and signed by the Licensors.

**"Applicable Revenue"** means the Gross Revenue less VAT (or other equivalent sales tax, as applicable).

**"Application for Licence" or "AFL"** means the IMRO and MCPSI General Entertainment Online Licence (Download to Own and On Demand Rental) application form.

**"Broadcast Service"** means a service (or the relevant part of a service) by which Content is broadcast (as that term is defined in the Broadcasting Act to Users via a Network, including simulcasts of a broadcast service. For the avoidance of doubt, to constitute a Broadcast Service, there must be no interactive functionality, for example (without limitation), no use of controls that enable the User to pause, skip, move forward or backwards through the stream or personalise in any way the content made available in the stream.

**"Commercial Work"** means each Musical Work the copyright in which is owned or controlled in the United Kingdom and Ireland by MCPS (or an MCPS member or an affiliated society or an affiliated society member) but excluding:

- (a) Production Music Works; and
- (b) a Commissioned Work, PROVIDED THAT for the purposes of clauses 3.2 and 4.3, a Commissioned Work shall not be excluded from such definition where the commissioning agreement does not authorise the Licensee to use the Commissioned Work in the context set out in those clauses.

**"Commissioned Work"** means a Musical Work specially and expressly commissioned by the Licensee from composer/writer members of IMRO and/or MCPS.

**"Content"** means, unless stated otherwise in the Cover Sheet, audio-visual material incorporating Musical Works and which is in the form of films, television programmes (including programmes equivalent to television programmes but which

have not been broadcast on traditional television channels) and Trailers. Audio-visual material which is licensable under the Licensors' Online Music Licence scheme (for example but without limitation, music videos, live concert performances or films of live concert performances by the artist performing particular Musical Works) shall not be deemed Content for the purposes of this Agreement and shall not be licensed hereunder.

**"Content Usage Declaration"** means the information set out in the Licensors' reporting format attached to this Agreement as Appendix 2.

**"Cover Sheet"** means the cover sheet to this Agreement detailing, among other things, the Licensee details and the Licensed Services covered by this Agreement.

**"Data Storage Device"** means any medium on which data can be stored (whether temporarily or permanently) whether existing now or invented in the future.

**"Download"** means the making available to the public of Content, whereby such Content may be retained by the User on a temporary or permanent basis.

**"Dramatico-Musical Work"** means any ballet, opera, operetta, musical, musical play or work of a similar nature.

**"Generic Promotions"** means any item of Content the purpose of which is to promote or advertise the Licensee, the Licensed Service (or specific Content made available on the Licensed Service) and/or any other service of the Licensee, including but not limited to an item of Content which merely features the logo and/or image and/or words associated with the Licensee or a 'channel' forming part of the Licensed Service (sometimes known otherwise as an 'ident'), but excluding all Trailers.

**"GEOL Service"** means a Permanent Download Service and/or an On Demand Rental Service.

**"Gross Revenue"** shall have the meaning set out in Appendix 1.

**"Licensed Service(s)"** means the service(s) set out on the Cover Sheet.

**"Licensors"** means IMRO and MCPSI.

**"MCPS"** means Mechanical-Copyright Protection Society Limited whose registered office is at 29-33 Berners Street London W1T 3AB.

**"Member"** means:

- (a) in the case of MCPS, each person, firm or company who or which, from time to time, has appointed MCPS as agent in relation to online exploitation either before or during the Term, PROVIDED THAT a member who has so appointed MCPS after the commencement of the Term shall only be regarded as a member for the purposes of this Agreement with effect from the date on which the Member so appointed MCPS; and
- (b) in the case of IMRO, any person, firm or company who or which, from time to time, pursuant to the Articles of Association of IMRO has been admitted either before or during the Term as a member of IMRO, PROVIDED THAT a member who has been so admitted after the commencement of the Term shall only be regarded as a member for the purposes of this Agreement with effect from the date of admission into MCPSI.

**"Musical Work"** means any musical work (as defined in the Act) and any lyrics or words written to be used with such musical work (if applicable). It includes any part of such a work.

**"Network"** means the internet, a mobile network or any other wired or wireless network.

**"On-Demand Rental Service"** means a service (or the relevant part of a service) whereby a User may, in return for a payment to the Licensee, access a specific item of Content for a limited rental period (i.e. 48 hours) either by streaming the Content on-demand via a Network or in the form of a Temporary Download downloaded to the Users Data Storage Device.

**"Online Music Licence"** means the Licensors' scheme known as the "Joint Online Music Licence" as published by the Licensors from time to time.

**"Permanent Download Service"** means a service (or the relevant part of a service), by which a piece of Content is communicated to the public via a Network in the form of a Download and where such Download may be retained by the User on a permanent basis, and the term "Permanent Download" shall be construed accordingly.

**"Permitted Excerpts"** refers only to Dramatico-Musical Works and means excerpts where the use of all such excerpts in any Content complies with all the following limitations:

- (a) the total duration of the excerpts does not exceed 20 minutes;

- (b) the use is not a "potted version" of the Dramatico-Musical Work;
- (c) the use is not or does not cover a complete act of the Dramatico-Musical Work;
- (d) each excerpt is not presented in a "dramatic form" as defined below; and
- (e) as regards ballets specifically devised for television or excerpts from existing ballets, the total duration does not exceed five minutes.

A dramatic form shall be deemed to be created only by a performance in which there is a distinct plot depicted by actors and where the story of the Dramatico-Musical Work and/or its associated words is woven into and carries forward the plot and its accompanying action (a dramatic form shall not, for example, be deemed to be created by the use of costume, scenery, and/or any dance routine merely to provide an acceptable presentation of the work). For the purposes of this paragraph the word "actors" shall include actors, singers, mimics and/or puppets.

**"PMSR"** means any production music sound recording being a sound recording (as opposed to a Musical Work) the copyright in which is owned or controlled in the United Kingdom and Ireland by MCPS (or an MCPS Member or an associated society or an associated society member) and where such party has authorised MCPS to license such recordings as so-called production or library music.

**"Production Music"** means Production Music Works and PMSRs.

**"Production Music Work"** means any Musical Work:

- (a) embodied on a PMSR; and
- (b) the copyright in which is owned or controlled in the United Kingdom and Ireland by MCPS (or an MCPS Member or an associated society or an associated society member).

**"Quarter"** means each of the periods from 1st January to 31st March, 1st April to 30th June, 1st July to 30th September, and 1st October to 31st December, throughout the Term.

**"Quarterly Advance"** means the sum set out in the Cover Sheet, excluding VAT (or other equivalent sales tax, as applicable).

**"Repertoire Work"** means:

- (a) in relation to the licence granted by MCPSI, Commercial Works, Production Music Works

and PMSRs, but excludes (i) any musical work forming part of a Dramatico-Musical Work and (ii) Commissioned Music; and

- (b) in relation to the licence granted by IMRO, each Musical Work the relevant copyright in which is owned or controlled, from time to time, in Ireland by IMRO or a Member or an associated society or an associated society member PROVIDED THAT if one or more of those who own or control the copyright in a relevant Repertoire Work is not IMRO or a Member or an associated society or associated society member, the expression "Repertoire Work" shall only apply to such interest in the Repertoire Work as is owned or controlled by IMRO or the associated society or the relevant member or associated society member.

For the avoidance of doubt, if a Musical Work is a Repertoire Work in relation to one Licensor and not the other then it remains a Repertoire Work under this Agreement in relation only to the licence granted by that Licensor.

**"Royalty Fees"** means the royalties payable, as set out in Cover Sheet.

**"Server Territory"** means the European Economic Area, Switzerland, the United States of America, Canada and such other territories as may be agreed in writing by the parties.

**"Service Provider"** means, the party which, in relation to a Licensed Service, most closely meets the following criteria:

- (a) contracts with the User in relation to the provision of the Licensed Service;
- (b) sets and controls the price the User pays;
- (c) can fully report on all elements of the gross revenue (including relevant advertising revenues) of the Licensed Service;
- (d) can fully report on all elements of music usage (or can procure such reporting);
- (e) controls how content is offered and bundled within the Licensed Service; and
- (f) carries out or authorises, on their instruction, the carrying out of the copyright restricted acts licensed under this Agreement.

**"Subscription Service"** means a service offered to consumers whereby consumers may access Content for a limited period of time (i.e. while the subscription continues) and in respect of which there would ordinarily be a subscription fee payable.

**"Temporary Download"** means a Download where the User is entitled to retain a copy of the

Download for a defined temporary period of time (i.e. not more than 30 days).

**"Term"** means the period starting on the Commencement Date and ending upon the date set out in clause 13.1 (unless terminated earlier under clauses 13.2 or 13.3).

**"Territory"** means Ireland

**"Trailer"** means an item of Content which is either:

- (a) the official film or television trailer produced and released by the producer of the relevant item of Content; or
- (b) an unedited clip of up to 90 seconds duration of the relevant item of Content being made available on the Licensed Service.

**"User"** means a natural person in the Territory who receives the Licensed Services for their own private and non-commercial use.

**"VAT"** means value added tax and each like tax imposed in addition to or in substitution therefor.

**"Voucher"** means a physical or online voucher or token which is pre-paid and allows a User to redeem that pre-payment against purchase of Content from the Licensed Service.

## 2. Grant of Licence

2.1 Subject to and conditional upon compliance with the terms and conditions contained herein and in particular subject to the exclusions and restrictions set out in clauses 3 and 4, MCPS grants the Licensee a non-exclusive licence to do the following during the Term:

- (a) to reproduce Repertoire Works incorporated into Content on servers within the Server Territory for the purpose of communicating to the public such Content to Users (for the User's own private and non-commercial use) by means of the Licensed Services; and
- (b) where the Licensed Services expressly authorise the temporary or permanent reproduction of Content on Users' Data Storage Devices, to cause copies of Repertoire Works incorporated into Content to be made in the Territory for the User's own private and non-commercial use; and
- (c) to make available to the public (as that term is defined in Section 40 (1) (a) only and to authorise the making



available to the public of PMSRs incorporated into Content within the Territory solely as part of and for the purposes of the provision of the Licensed Services; and

- (d) notwithstanding clause 3.2, to extend an existing synchronisation licence which has previously been granted by the copyright owner to reproduce Repertoire Works in Content for exploitation in an alternative media to that licensed under this Agreement so that such synchronisation is licensed for the purpose of making available the Content on the Licensed Service.

2.2 Subject to and conditional upon compliance with the terms and conditions contained herein and in particular subject to the exclusions and restrictions set out in clauses 3 and 4, IMRO grants the Licensee a non-exclusive licence, during the Term, to make available to the public (as that term is defined in Section 40 (1) (a) only within the Territory and to authorise the making available to the public within the Territory of Repertoire Works incorporated into Content solely as part of and for the purposes of the provision of the Licensed Services.

2.3 The provisions of clauses 3.5, 3.6, 4.1, 4.2, and 4.3 shall not apply to a particular Repertoire Work where the owner of the relevant rights in such Repertoire Work has granted permission to the original producer of the Content for the use of that Repertoire Work in the Content in the manner described under the relevant clause on such terms and conditions (including, if required, the payment of royalties or fees in addition to those specified under this Agreement) as the owner thinks fit.

2.4 The licence granted under clause 2.1 above shall not apply to Commercial Works included in Generic Promotions.

### 3. Exceptions and Limitations

3.1 The licences granted under clause 2 of this Agreement are valid only insofar as:

- (a) the Licensed Services are GEOL Services; and
- (b) Content is made available in consideration of the payment by the User of a charge or fee for each item of Content purchased or rented. Content made available as part of a Subscription Service shall not be licensed under this Agreement; and
- (b) the Licensee is the Service Provider in relation to the Licensed Services.

3.2 For the avoidance of doubt, this Agreement does not grant any "synchronisation licence" covering the initial fixation of Repertoire Works in combination with visual images to create and produce Content.

3.3 For the avoidance of doubt, the licences granted under clause 2 of this Agreement shall not authorise the manufacture or distribution of physical products containing Content, such as (without limitation) the ordering of compact discs (or any other type of physical media), but which are distributed by mail.

3.4 For the avoidance of doubt, the licences granted under clause 2 of this Agreement shall not extend to the performing, sharing or playing of a copy (as that term is used in the Act) of Repertoire Works, whether as part of the Licensed Services or otherwise.

3.5 Unless (i) the relevant Member has expressly consented to such use being covered under the MCPSI licence granted herein, (ii) the Licensee has entered into an agreement with the relevant Member to this effect and (iii) evidence of such agreement has been provided to the Licensors, the licence granted under clause 2.1 of this Agreement shall not permit the use of Repertoire Work(s) with any advertising or sponsorship where:

- (a) such Repertoire Work(s) are incorporated into such advertising or sponsorship; or
- (b) such Repertoire Work(s) are otherwise presented in such a way that a reasonable person might associate the Repertoire Work(s) with the advertising or sponsorship.

3.6 Unless (i) the relevant Member has expressly consented to such use being covered under the MCPSI licence granted herein, (ii) the Licensee has entered into an agreement with the relevant Member to this effect and (iii) evidence of such agreement has been provided to the Licensors, for the avoidance of doubt (and without prejudice to the generality of clause 3.5), the licence granted under clause 2.1 of this Agreement shall not apply to any Content made available for the purpose of (whether in whole or in part):

- (a) directly or indirectly encouraging the User to purchase or obtain goods or services of whatsoever nature; or

(b) promoting the branding of the Licensee, any affiliate of the Licensee or any third party in such a manner that:

- (i) one or more particular Repertoire Works, composers or writers are associated with such promotion; or
- (ii) a reasonable person might assume that there was an association between particular Repertoire Works, composers or writers and such promotion;

3.7 The licence granted under clause 2.1 shall not apply to graphic copies (meaning, without limitation, copies of lyrics, notation or scores) of Repertoire Works. For the avoidance of doubt, the licences granted under these terms and conditions shall not apply to any "karaoke" service.

3.8 For the avoidance of doubt, this Agreement grants no licence whatsoever in relation to:

- (a) Repertoire Works which are made available by the Licensee outside of the Licensed Service(s); or
- (b) material containing Repertoire Works (other than Content) that is made available by the Licensee, even where such material is made available together with Content.

However, such other exploitation of Repertoire Works may fall within the scope of other licensing schemes operated by the Licensors, details of which shall be made available to the Licensee on request.

#### 4. Further Restrictions

4.1 Where any Repertoire Work forms part of any Dramatico-Musical Work, the licence granted under clause 2.1 shall not apply, in relation to Content, to the reproduction of:

- (a) the whole Dramatico-Musical Work; or
- (b) any excerpt(s) from such Dramatico-Musical Work unless all of the following circumstances apply:
  - (i) that which is copied or communicated to the public via the Licensed Services under this Agreement contains only excerpt(s) within the definition of Permitted Excerpts; and
  - (ii) neither of the Licensors has notified the Licensee in writing that their Member or the

associated society member objects to the reproduction of any such Repertoire Work.

In any event, any licence hereunder only applies to the relevant Repertoire Works and not (by way of example only) to any underlying dramatic or literary work which forms part of the Dramatico-Musical Work or which such Dramatico-Musical Work is based on or uses.

4.2 The licences granted under this Agreement shall not extend to or permit any adaptation of any Repertoire Work to be copied or communicated to the public as part of a Licensed Service unless the relevant Member has consented to such adaptation. By way of example only, this applies to:

- (a) any sampling (meaning the taking of part of the music and/or lyrics of a Repertoire Work and incorporating such part into another Musical Work) or the communication to the public or reproduction in the form of a sample of such part of a Repertoire Work; or
- (b) using with music lyrics other than those written to be used with the music or authorised for use with the music; or
- (c) using with lyrics music other than that written to be used with the lyrics or authorised for use with the lyrics.

4.3 The licences granted under this Agreement do not extend to the reproduction of any Commercial Work:

- (a) where the Content is of an overtly political, sexual, violent or religious nature; or
- (b) in the form of a parody, pastiche or burlesque of any Commercial Work or of any composer or writer of any Commercial Work or any band or other group of artists which includes any composer or writer of any Commercial Work; or
- (c) where there is a derogatory, facetious, obscene or demeaning reference to the Commercial Work, its composer(s) and author(s) or the performing artist; or
- (d) without prejudice to clauses 3.5 and 3.6 above, in any manner which is likely to or causes the public to believe that the Commercial Work (or the composer(s) thereof) is endorsing or promoting any product or service,

or the views expressed in the Content;  
or

- (e) where the making available of the Content constitutes a criminal offence under the laws of Ireland.

Whether a use of a Commercial Work breaches this clause 4.3 shall be decided by the Licensors in their reasonable discretion.

- 4.4 All rights not specifically granted under this Agreement are hereby reserved.
- 4.5 This Agreement only covers Repertoire Works. It does not extend to other rights or interests, including (by way of example only), rights in sound recordings other than PMSRs, films, dramatic works, performers' rights or rights in performances. The Licensee is required to obtain the appropriate waivers, consents and/or licences from the person(s) owning or controlling rights in relation to sound recordings containing Repertoire Works or performers of that Repertoire Work.
- 4.6 It is the responsibility of the Licensee to obtain all necessary licences in relation to any Musical Work which is not, or to the extent that it is not, a Repertoire Work, and no licence is granted under this Agreement in relation thereto.
- 4.7 Nothing in this Agreement affects the moral rights of authors of Repertoire Works whether subsisting in Ireland or any other territory.

## **5. Fees and Payment**

- 5.1 In consideration of the licences and authorisations granted under this Agreement, the Licensee shall pay to the Licensors:
- (a) the Quarterly Advance; and
- (b) subject to clause 5.2, the Royalty Fees.
- 5.2 The Quarterly Advance is recoupable against the Royalty Fees. If any part of the Quarterly Advance remains unrecouped at the end of a Quarter, such unrecouped amount may be carried over to subsequent Quarters, but for the avoidance of doubt, shall not (except as set out in clause 5.3 below) have the effect of reducing any subsequent Quarterly Advance. If any part remains unrecouped upon termination or expiry of the Agreement, the Licensors shall return such part to the Licensee.
- 5.3 The Quarterly advance shall be reviewed by the Licensors at the end of each calendar year. It may also be reviewed by the

Licensors during a calendar year if the royalties calculated for any particular Quarter differ from the Quarterly Advance by 20% or more.

- 5.4 Where, in relation to any particular Quarter, the Licensee fails to provide by the required date the information required under the Agreement to allow the calculation referred to in clause 5.1(b), then the Licensors shall be entitled to fix the Royalty Fee based on (a) the Royalty Fees payable in previous Quarters and (b) any other relevant factors which could reasonably lead the Licensors to believe that the Royalty Fees payable would be materially different to those paid or payable in previous Quarters.
- 5.5 The Quarterly Advance shall be payable by direct debit on the first day of each Quarter. Where the Agreement begins (and/or a Licensed Service comes into operation) within a Quarter, the first Quarterly Advance payment shall be pro-rated (according to the Commencement Date) and shall be payable upon the later of signature of this Agreement and the date on which the first Licensed Service is made available to Users for the first time.
- 5.6 Upon receipt of the Content Usage Declaration from the Licensee pursuant to clause 6.1 below, IMRO shall, on behalf of the Licensors, each of the Members, raise an invoice for the due amount, and the Licensee shall pay such invoice by electronic bank transfer (or, if agreed by the Licensee, direct debit) within 21 days of the invoice date.
- 5.7 All licence fees and payments referred to in this Agreement are subject to VAT or other equivalent sales tax. The Licensee shall pay to the Licensors VAT or other equivalent sales tax (if applicable) at the rate or rates from time to time in force on any sums payable under this Agreement.
- 5.8 Except as expressly set out in these terms and conditions, no deduction in respect of any tax, or any other deduction or set-off of whatsoever nature, shall be made in calculating or paying any sum due under this Agreement.
- 5.9 Without prejudice to any other right or remedy of the Licensors, and without imposing an obligation to accept late payment, where any fees payable under this Agreement are not paid by the due date (or the date on which such fees should ordinarily have been paid in circumstances where the Licensors have

been unable to submit an invoice) due to default of the Licensee, the Licensee shall (if required by the Licensors) pay interest on such late payment calculated on a daily basis at an annual rate of 3% over the prime overdraft rate, current from time to time, of Bank of Ireland payable from the date on which the payment should have been made to the date on which the payment was made.

5.10 All payments made under this Agreement shall be in Euro unless otherwise agreed by the parties in writing. Where it is necessary to convert an amount payable to Euro from another currency, the exchange rate used shall be the Irish Times closing mid market rate on the first working day of the Quarter to which the payment relates. The Licensee shall pay all bank charges on transfers of sums payable by the Licensee to the Licensors.

5.11 The Licensee shall notify the Licensors promptly of any change in the Licensed Service details provided in the Application for Licence (or set out on the Cover Sheet) and the effective date of such change. If the Licensee wishes to launch an additional Licensed Service, it shall not be licensed under this Agreement until the parties have agreed an appropriate increase to the Royalty Fees.

5.12 The Licensee shall be entitled to include as part of a Licensed Service free audio-visual clips and Trailers incorporating Musical Works without the payment of any additional Minimum Royalty provided that such clip or Trailer is used solely to promote the sale or other use of the Content as part of the Licensed Service.

5.13 On a non-precedential basis, the Licensors shall not apply an CPI based increase to the Minimum Royalties at the start of the second calendar year of the Term.

## **6. Supply of Information**

6.1 In relation to any and all Content reproduced and communicated to the public under this Agreement via the Licensed Services, the Licensee will deliver a fully and accurately completed Content Usage Declaration to the Licensors or to the Licensors' duly authorised agent (details of which will be provided to the Licensee) within 14 days of the end of each Quarter throughout the Term.

6.2 The Licensee must also supply the Licensors with any further information or documentation in its possession, power, custody or control (and use its reasonable endeavours to supply the Licensors with any further information or documentation not in

its possession, power, custody or control) reasonably requested by the Licensors at any time, in order to enable the Licensors to verify the Repertoire Work(s) which have been reproduced or distributed via all Licensed Services.

6.3 The email address for delivery of the Content Usage Declaration referred to in clauses 6.1 is [onlinelicensing@imro.ie](mailto:onlinelicensing@imro.ie)

6.4 Without prejudice to any right in law that the Licensors may have to obtain such information, the Licensee shall not be obliged to provide to the Licensors any information which identifies Users or which otherwise constitutes "personal data" as defined in the Data Protection Acts 1988. For the avoidance of doubt, the Licensee must still provide all required information in the Content Usage Declaration (or other information to be provided under this Agreement), but is entitled to remove any element of it which reveals the identity of Users or otherwise causes it to include or constitute "personal data".

## **7. Late Reporting**

7.1 The following provision applies where the Licensee has:

(a) failed to deliver prior to the required date the Usage Declaration for the Licensed Service; or

(b) delivered such Content Usage Declaration prior to the required date, but it contains any omission or error of whatsoever nature (by way of example only, Content having been omitted therefrom or incorrectly or misleadingly named, or the duration of any Content having been under-reported) which is material and the Licensee has failed to give notice in writing to the Licensors correcting the omission or error by the date upon which such reporting should have been provided.

7.2 In such circumstances (and without prejudice to any other rights which either or both Licensors may have against the Licensee) if one or both of the Licensors has distributed some (or all) royalties received (excluding any commission) to Members and/or Associated Societies based on the usage data supplied, but, as a result of clause 7.1(a) or (b) applying, the royalties distributed do not accurately or fairly represent that which each of the Members and/or Associated Societies should have received (when considering the true usage of Content), then the Licensee shall pay the fees set out in

clauses 7.3 and 7.4 (in addition to those set out in clause 5).

- 7.3 Where clause 7.2 applies, separately in relation to each relevant item of Content either omitted from the relevant Content Usage Declaration or as regards which there was a material omission or error of whatsoever nature or in relation to which the relevant Content Usage Declaration was not delivered, the additional fees shall be calculated at the rate equivalent to that which has been or will be paid by MCPSI and/or IMRO (as applicable) to their members (or associated societies) in relation to the Content Usage Declaration which was submitted prior to the required date.
- 7.4 Where clause 7.2 applies, the Licensee will also pay interest on the additional fees as referred to in clause 7.3 above computed in accordance with clause 5.9 and calculated from the date on which MCPSI and/or IMRO (as applicable) first made a distribution to their members (or associated societies) in relation to the relevant period to the date on which the Content Usage Declaration was received by the Licensors or the date on which the Licensors received written notice of the relevant error, as the case may be.
- 7.5 The provisions of this clause apply notwithstanding any other provision of this Agreement, but are without prejudice to any other right which MCPSI and IMRO have in relation to any failure to submit Content Usage Declaration fully or accurately completed within the time stipulated in clause 6.1.

## **8. Vouchers**

- 8.1 The licence under clause 2.1 only applies to Licensed Services purchased using Vouchers where each such Voucher:
- (a) contains no branding other than that of the Licensee; and
  - (b) does not refer to any specific item of Content; and
  - (c) does not otherwise contravene the limitations and restrictions set out in this Agreement (in particular clause 3.5 and 3.6).

Content provided via a Voucher scheme which is outside this clause 8.1 are not licensed under this Agreement and a separate licence for premium usage of this type must be sought from the Licensors.

- 8.2 The price of each Voucher shall be included in Gross Revenue if and to the extent that it is redeemed by a User or Users.

## **9. Bundling**

Unless specified in the Cover Sheet the licences granted in this Agreement do not apply to the bundling of Content with other content, goods or services.

## **10. Credits and Notices**

- 10.1 The Licensee shall include on each of the Licensed Services:

- (a) the logo of *IMRO and MCPSI*; and
- (b) details of the following website and, where practical, hypertext links to it:  
<http://www.imro.ie>

Approval of the Licensors shall be deemed to be given to the positioning of the above credits and notices within the terms and conditions of the Licensed Service(s) where it is not reasonably practical to position such information elsewhere.

## **11. Auditing**

- 11.1 The Licensee shall keep and make available for inspection upon reasonable notice (and shall procure that each Relevant Party keeps and makes available for inspection upon reasonable notice), both during and for twelve months after termination or expiry of this Agreement, proper, detailed books and records relating to (a) the use of all Content and (b) any income or other consideration received by or on behalf of the Licensee in relation to the Licensed Services, together with any supporting documentation relating thereto covering the period up to six years prior to the date of notification of audit. Where any agreement between the Licensee and the Licensors replaces this Agreement or licenses substantially the same activities (the "**Replacement Agreement**"), the twelve month time-limit referred to above shall begin following termination or expiry of the Replacement Agreement.
- 11.2 For the purposes of this clause 11, the Licensee shall allow upon reasonable notice (and shall procure that each relevant party shall allow) access to its premises to inspect relevant accounting records, but not more than once per annum. The duly authorised representatives (who shall be external qualified accountants or auditors unless otherwise agreed between the parties) of the Licensors shall have such access to the Licensee's premises and shall be entitled to inspect, make extracts and

take copies of any of the information and/or documentation available and to carry out such work as is, in their reasonable opinion, considered necessary to verify compliance with the provisions of this Agreement.

- 11.3 If tests under any audit and verification process indicate under-payment of the correct Royalty Fee during the period under audit, then, without prejudice to the Licensors' other rights under this Agreement, the Licensee shall pay the amount of the underpayment plus interest based on the period from which the correct fee should have been paid to the Licensors to the date when it was actually paid (at the rate set out in clause 5.9).
- 11.4 If any audit and verification process discloses (a) under-payment of more than 7.5% of the correct Royalty Fee during the period under audit and/or (b) failures to report correctly (so as to affect a distribution by the Licensors to their Members) amounting to at least 7.5% of the Content usage during the period under audit, then, without prejudice to the Licensors' other rights under this Agreement, the Licensee shall pay, in addition to the payment referred to in clause 11.3, the Licensors' reasonable costs of such audit and verification within 28 days of receipt of the Licensors' VAT invoice therefore.
- 11.5 If tests under any audit and verification process indicate over-payment of the correct Royalty Fee during the period under audit, then the Licensors shall, as soon as is reasonably practical, pay the amount of the overpayment back to the Licensee (but, for the avoidance of doubt, no interest shall be payable unless the overpayment is a result of an act or omission of the Licensors (in which case interest shall be payable at the rate set out in clause 5.9)). However, where the overpayment does not result from an act or omission of the Licensors and the Licensors have already distributed such overpayment to their Members and/or Associated Societies, the Licensors shall be entitled to deduct its reasonable internal and/or external costs in administering the payment back of the overpayment.
- 11.6 The Licensors shall not (and shall procure that their representatives shall not), without the Licensee's written consent, disclose to any third party any confidential information of the Licensee (so long as it remains confidential) received in the course of an audit carried out under this clause 11, save that such confidential information may be disclosed to the Licensors' directors, board sub-committee members, officers, employees and professional advisors (solely

where such persons are under a duty of confidentiality in relation to information so received and the Licensors shall be liable to the Licensee in respect of any breach of such confidentiality obligation) solely for purposes connected with this Agreement.

- 11.7 For the avoidance of doubt, books, records and accounting records as referred to in clauses 11.1 and 11.2 above shall include data, information and records held on computers.

## **12. Security and Encryption**

- 12.1 Unless agreed otherwise, the Licensee will utilise or require the utilisation of an industry security standard which is developed and is available for use in the protection of Repertoire Works. Until such time, the Licensee must use its reasonable endeavours to prevent unauthorised copying and/or the unauthorised issuing of copies of Repertoire Works by whatever technical means are practicable. Upon request the Licensee will inform the Licensors concerning its progress in relation to fulfilling this obligation.

## **13. Termination and Expiry**

- 13.1 This Agreement shall expire on 31 December 2017 (or such other date as may be stated on the Cover Sheet) unless terminated earlier in accordance with the terms of this clause 13.
- 13.2 This Agreement may be terminated by the Licensee, by giving not less than three months written notice to the Licensors or upon written notice in circumstances where the Licensee is ceasing to engage in activities covered by this Agreement.
- 13.3 Each party shall have the right to terminate this Agreement by notice forthwith where the other party:
- (a) commits a material breach of this Agreement which is capable of remedy and fails to remedy such breach within 14 clear days after receipt of notice of such breach; or
  - (b) commits a material breach of this Agreement which is not capable of remedy; or
  - (c) the other goes into receivership or any resolution is passed for its winding-up or liquidation (other than for the purposes of reconstruction or amalgamation) or is otherwise unable to pay its debts,

and, for the avoidance of doubt, any breach which consists of a failure by either party to perform an obligation under this Agreement within any period required or by any date specified under this Agreement shall be deemed to be capable of remedy if such obligation is performed by such party within the 14 day remedy period specified in clause 13.3(a) above.

#### **14. No Assignment**

14.1 The licences granted under this Agreement are personal to the Licensee and the Licensee may not assign, sub-license or otherwise transfer any or all of its rights or obligations under this Agreement without the written agreement of both MCPSI and IMRO.

#### **15. Miscellaneous**

15.1 No delay or omission in exercising any right or remedy hereunder shall operate as a waiver thereof or of any other right or remedy and no single or partial exercise thereof shall preclude any other or further exercise thereof or the exercise of any other rights or remedies. No waiver shall be binding or effectual for any purpose unless expressed in writing and signed by the party giving it and any such waiver shall be effective only in the specific instance and for the purpose given.

15.2 This Agreement sets forth the entire agreement of the parties in relation to the subject matter hereof and each of the parties hereto acknowledges that it has not entered into this Agreement in reliance on any representation or term not contained in this Agreement. This Agreement shall not be modified or varied except by a written instrument signed by the parties hereto.

15.3 The headings to the clauses in this Agreement are included for ease of reference only and are not part of this Agreement and are not to be taken into account in its construction.

15.4 The parties shall (and shall procure that any other necessary party within its control shall) execute all such documents and do all such acts and things as may be reasonably be required on or subsequent to completion of this Agreement for securing each of the obligations of the respective parties under this Agreement.

15.5 If this Agreement creates any rights which would in the absence of this provision be enforceable by any person not a party to this Agreement, such rights shall not be enforceable.

15.6 This Agreement shall be construed according to the laws of Ireland and the parties agree to submit to the jurisdiction of the Irish Courts.

## Appendix 1

### Gross Revenue Definition

#### Definitions

“**Gross Revenue**” means, subject to the provisions of this Appendix 1:

- (a) all revenue received (or receivable) by the Licensee from Users in consideration for the provision of the Licensed Services; and
- (b) all revenue, including by way of sponsorship and commissions, received (or receivable) by the Licensee as a result of the inclusion of third party advertising “in-stream” or “in-download” as part of the Licensed Service, being advertising placed immediately at the start, end or during the actual delivery (by way of streaming or downloading as applicable) of Content to a User; and
- (c) all revenue, including by way of sponsorship, click-throughs and other commissions, received (or receivable) by the Licensee as a result of the placement of third party advertising, buy or click-through buttons on a Relevant Page (as defined below) of the Licensed Service (and including any page which directly follows such Relevant Page leading up to and including the downloading or streaming of the Content offering);

and in each of the above cases such revenue shall, for the avoidance of doubt, include any such revenue whether received or receivable by the Licensee or any associate, affiliate, agent or representative of such party.

Subject to the remainder of this Appendix 1, there shall be no other deduction or set-off from the above revenues other than reasonable refunds to Users for services that they were unable to use (but had paid for) due to technical faults in the Licensed Services.

“**Relevant Page**” means a page:

- (a) from which Licensed Services are “actually offered” to Users. A Licensed Service is “actually offered” to Users from a page if Content is enabled or made directly available from that Licensed Service to the User to download or stream from that page (in most cases this will be where such Content can be purchased by the User or their download or stream otherwise takes place); but only
- (b) where such offering forms all or the predominant part of that page, being for the purposes of this Agreement where the offering comprises 75% or more of the space on that page excluding space occupied by any advertising. For the purposes of performing the foregoing calculation, the “offering” shall include any content which directly relates to the actual offering of the Licensed Service pursuant to sub-paragraph (a) above (by way of example, but without limitation, an image of the artist or artwork closely associated with the offering, reviews of the offering, credits, and media player controls).

#### 1. General

- (a) The Licensors’ experience of the “Relevant Page” concept is that it does not always work in practice. As a result, the Licensors reserve the right to discuss with the Licensee an alternative construct for ensuring that appropriate revenue is accounted to the Licensors and that it can be accounted accurately. Any agreed alternative construct shall be set out in the special conditions on the Cover Sheet. If the parties are unable to agree on such alternative construct, the Licensors reserve the right to apply the dispute resolution procedure referred to in paragraph 2(d) below.
- (b) For the avoidance of doubt, the definition of Gross Revenue above shall be applied in conjunction with the provisions on bundling set out in clause 19 of the terms and conditions. The Licensors confirm that no revenue which is included in Gross Revenue under this Agreement shall form any part of the “revenue base” under any other licence or licensing scheme operated by the Licensors (or either of them) which grants all or some of the rights set out in clauses 2.1 and 2.2 of the terms and conditions (albeit in relation to a service which is not a Licensed Service hereunder).
- (c) For the further avoidance of doubt, revenue which relates solely to services other than the Licensed Service shall not be included in the Gross Revenue.
- (d) For the further avoidance of doubt, Gross Revenue shall not be reduced by credit card commissions or similar payment process charges.

#### 2. Advertising and Sponsorship Revenue

- (a) Gross Revenue obtained in the form of advertising or sponsorship revenue shall be reduced by any commission amount that has been deducted only by external third party advertising agencies (not being in any way affiliated to the Licensee) used to sell advertising on behalf of the Licensee, subject the maximum deduction being 15%.
- (b) For the avoidance of doubt, advertising revenue referred to in sub-paragraph (c) of the definition of Gross Revenue above shall not include revenue arising from sponsored searches or click-through commissions arising from such searches.
- (c) The provisions of paragraph 2(d) below shall apply if a dispute (a “Dispute”) arises in relation to the application of the provisions of this Appendix 1 as to what revenue is included within the definition of Gross Revenue.
- (d) Provided that the Licensors and the Licensee shall have held substantive negotiations in good faith regarding the subject matter of the Dispute over a period of at least 21 days from the date on which the Licensors notify the Licensee or the Licensee notifies the Licensor (as the case may be) in writing of the existence of such Dispute, the Licensors or the Licensee shall then be entitled by notice in writing from the Licensors to the Licensee or by the Licensee to the Licensors



to refer the Dispute for determination to an independent online adjudicator acting as an expert. The identity of such expert shall either be agreed or, in the absence of such agreement within 7 days of the written notice of referral, shall be determined by the President for the time being of the Institute of Chartered Accountants, and shall be an independent chartered accountant, unless the Licensors and the Licensee agree that another type of expert would be more suitable to determine such Dispute. The Licensors and the Licensee will seek to agree the procedure for the conduct of any expert determination. If such agreement is not reached within 7 days of the appointment of the expert, the expert shall have power to set the procedure for the expert determination. The expert shall be required, in particular, to take into account any part of the Copyright Tribunal's decision in Reference 84-90/05 relevant to the Dispute in reaching his decision. The expert shall make his determination as soon as reasonably practicable. The expert shall have power to award costs in the expert's determination, unless the Licensors and the Licensee agree otherwise. The decision of the expert is final and binds the parties to the Dispute unless there is manifest error, wilful default or fraud. For the avoidance of doubt, it is hereby confirmed that the expert shall have no jurisdiction to amend any term of the Agreement.

***Appendix 2***

**Content Usage Declaration**

(to be inserted)

# IMRO Music Downloading Licence

**AN AGREEMENT** made

**BETWEEN (1) IRISH MUSIC RIGHTS ORGANISATION CLG** whose registered office is at Copyright House, Pembroke Row, Lower Baggot Street, Dublin 2 ("IMRO") and [\_\_\_\_\_], whose registered office is at [\_\_\_\_\_], ("the Licensee")

## **WHEREAS:**

- A. The Licensee wishes to Make Available to the Public by wire or wireless means Musical Works and/or words associated therewith in the Repertoire of IMRO (as hereinafter defined), and
- B. The service operated by the Licensee is not one to which the 'Joint MCPSI and IMRO Licensing Scheme for the Provision of Online and Mobile Music Services to the Public for Private Use' or 'Joint MCPSI and IMRO Limited Online Exploitation License for Private Use' should apply, and,
- C. The service operated by the Licensee is not one that involves the Making Available to the Public of Musical Works and/or words associated therewith, as part of a ringtone/ringback service.

**NOW IT IS HEREBY AGREED** as follows:-

1. In this agreement, unless the context otherwise requires:-

<b>"Applicable Revenue"</b>	means the Gross Revenue less VAT (or other equivalent sales tax, as applicable).
<b>"Copyright Owner"</b>	shall mean in respect of any act in relation to a Musical Work, or words associated therewith, the person in whom for the time being is vested the right to authorise other persons to do that act.
<b>"Download Music Service"</b>	shall mean a music service falling within the definition set out in schedule 2.
<b>"Dramatico-musical Work"</b>	shall mean an opera, operetta, musical play, revue or pantomime, insofar as it consists of words and music written expressly therefor.
<b>"Excluded Service"</b>	means any service (or the relevant part of a service) which is a podcasting service or which falls within the scope (from time to time) of any of the following MCPSI/IMRO joint licensing schemes or any licensing schemes operated by IMRO or MCPSI (Mechanical Copyright Protection Society Ireland Ltd.)  a) IMRO – Ringtone/Ringback Licensing

## **IMRO Music Downloading Licence**

### Scheme

- b) MCPSI – Ringtone Licensing Scheme
- c) MCPSI – Ringback Licensing Scheme
- d) MCPSI – Karaoke and MIDI Scheme
- e) MCPSI – Music-on-hold Scheme
- f) MCPSI – Supply of Background Music Services Scheme
- g) MCPSI – Premium Telephone Line Services Scheme
- h) IMRO/MCPSI – Limited On-Line Exploitation Licensing Scheme
- i) IMRO/MCPSI - General Entertainment on Demand Licensing Scheme
- j) IMRO/MCPSI – Licensing Scheme for the Provision of Online and Mobile Music Services to the Public for Private Use
- k) IMRO - Online excluding JOL Music Services & Ringtones/Ringbacks

### **“Gross Revenue”**

shall mean:

- a) all revenue received (or receivable) by the Licensee from Users in relation to the provision of the Licensed Services; and
- b) all revenue received (or receivable) by the Licensee as a result of the placement of advertising on or within the Licensed Services; and
- c) all revenue received (or receivable) by the Licensee as sponsorship fees in relation to the provision of the Licensed Services; and
- d) all revenue received (or receivable) in the form of commissions from third parties as a result of Users accessing and/or purchasing from a service of a third party via the Licensed Services; and
- e) any other revenue received (or receivable) by the Licensee arising in relation to the

## **IMRO Music Downloading Licence**

provision to Users of the Licensed Services (including, without limitation, such revenue received in relation to donations, barter or contra deals, such deals to be valued for these purposes);

- f) and in each of the above cases such revenue shall, for the avoidance of doubt, include any such revenue whether received or receivable by the Licensee or any associate, affiliate, agent or representative of such party.
- g) There shall be no other deduction or set-off from the above revenues other than refunds to Users for services that they were unable to use due to technical faults in the Licensed Services.

<b>"Licence Year"</b>	shall mean a period of 12 months beginning on 1st January and any subsequent anniversary thereof.
<b>"Licensed Service"</b>	shall mean the music service listed in schedule 4.
<b>"Making Available to the Public"</b>	shall have the meaning of any act referred to in Section 40(1)(a) of the <a href="#">Copyright and Related Rights Act 2000</a> .
<b>"Musical Work"</b>	means any musical work (as defined in the Act) and any lyrics or words written to be used with such musical work (if applicable). It includes any part of such a work.
<b>"Network"</b>	means the internet, a mobile network or any other wired or wireless network.

## IMRO Music Downloading Licence

**"Repertoire of IMRO"** shall mean all or any Musical Works including any words associated therewith in which rights to Make Available to the Public and to authorise others to do the same are or may be at any time during the term of this Agreement vested in IMRO in the territory.

**"Territory"** means the Republic of Ireland

**"User"** means a natural person in the Territory who receives the Licensed Services for their own private and non-commercial use.

2. Subject to the exemptions and limitations above, and hereinafter set out, IMRO hereby grants to the Licensee licence and authority to Make Available to the Public the Repertoire of IMRO.
3.
  - (i) The extent of the licence and authority hereby granted is set out in Schedule 1 hereto which schedule may be amended from time to time pursuant to any change in the extent of rights administered by IMRO. IMRO shall inform the Licensee in advance, if possible, if not as soon as possible thereafter of any change so made and shall supply the Licensee with a revised version of Schedule 1.
  - (ii) In the event of any substantial amendment to Schedule 1 either party may require renegotiation in good faith of the terms of this Agreement without prejudice to the rights of either party under Clause 7.
4. In consideration of the licence and authority hereby granted the Licensee shall make payments to IMRO in accordance with the provisions set out in Schedule 3 hereto. In the event that the Licensee shall be in arrears for 45 days after receipt of invoice from IMRO the Licensee shall pay IMRO interest on the amount overdue calculated on a daily basis at the rate of 6 per cent per annum without prejudice to IMRO's rights of termination under Clauses 7 and 8.
5. The Licensee shall supply to IMRO lists identifying, to the reasonable satisfaction of IMRO and in an electronic form acceptable to IMRO, details of Musical Works (and any words associated therewith) included in the Making Available to the Public right, these lists to be supplied within 2 weeks of the end of each calendar quarter and will include title of the work, composer/artist, cost per download and number of times each work was downloaded during the preceding quarter.

## IMRO Music Downloading Licence

6. Each of the parties hereto shall during the continuance in force of this agreement furnish to the other promptly all information in its possession sufficient to enable either party to protect its interests.
7. If
  - (a) either IMRO or the Licensee goes into receivership or any resolution is passed for its winding-up or liquidation (other than for the purposes of reconstruction or amalgamation)
  - (b) any substantial amendment is made to Schedule I by IMRO pursuant to clause 3
  - (c) either party commits any breach of its obligations under this Agreement which is not remedied within 30 days of written notice of the breach requiring its remedy then the other party may terminate this Agreement forthwith by notice in writing without prejudice to any right of action accrued prior to the date of termination.
8. This Agreement shall continue until the 31<sup>st</sup> December 2019 unless terminated by either party giving to the other 1 calendar month's notice or unless terminated in accordance with clause 7 above.
9. This Agreement is personal to the Licensee. The Licensee shall not be entitled to assign any of its rights and obligations hereunder without the prior written consent of IMRO, unless in the event of any amalgamation or reconstruction of its business, such consent not to be unreasonably withheld.
10. This Agreement shall be construed under the laws of the Republic of Ireland and both parties hereby submit to the non-exclusive jurisdiction of the Irish courts.

**AS WITNESS** the hand of \_\_\_\_\_ for and on behalf of IMRO

and the hand of \_\_\_\_\_ for and on behalf of the Licensee

# IMRO Music Downloading Licence

## SCHEDULE 1

For the avoidance of doubt, the licence granted in Clause 2 covers the Making Available to the Public Right in the Licensed Repertoire only, and does not cover the reproduction or copying of any Licensed Repertoire, either by the Licensee or by any User.

The licence granted in clause 2 of this Agreement **shall not** extend to nor authorise the Making Available to the Public of:-

1. a Dramatico-musical Work;
2. words written for the purpose of a commercial advertisement unless such words are sung to music specially written for a commercial advertisement or to non-copyright music and the sung performance has a duration of not less than five seconds;
3. unless specifically authorised in writing by IMRO or the Copyright Owner
  - (a) any musical work accompanied by any words other than those (if any) published or otherwise associated therewith by the copyright owner;
  - (b) any musical work with or without associated words in any adapted or rearranged form in such manner as to produce parodied or burlesqued effects;
4. any Musical Work, with or without associated words, in a dramatic form. A dramatic form shall be deemed to be created only by performance in a programme in which there is a distinct plot depicted by authors and where the story of the Musical Work and/or its associated words is woven into and carries forward the plot and its accompanying action. (A dramatic form shall not for example be deemed to be created by the use of costumes, scenery and/or dance routine merely to provide an acceptable presentation of the work). For the purposes of this paragraph, the word "actors" shall include actor-singers, mimers and/or puppets;
5. any Musical Work by means of a recording if the making of such recording infringed the copyright in such work;
6. any words associated with a Musical Work or ballet if unaccompanied by the music thereof;
7. Musical Works as part of an online and mobile service where such music is a substantial part of that service and where either the 'Joint MCPSI and IMRO Licensing Scheme for the Provision of Online and Mobile Music Services to the Public for Private Use' or 'Joint MCPSI and IMRO Limited Online Exploitation License for Private Use' should apply;
8. Musical Works as part of a ringtone and/or ringback service;
9. the Making Available to the Public of Musical Works to users outside the Republic of Ireland.



# **IMRO Music Downloading Licence**

## **SCHEDULE 2**

### **Definition of Download Music Service**

**“Permanent Download Service”**

means a service (or the relevant part of a service), other than an Excluded Service, by which a Musical Work is made available to the public via a Network in the form of a download and where such download may be retained by the User on a permanent basis, and the term “Permanent Download” shall be construed accordingly.



# IMRO Music Downloading Licence

## SCHEDULE 4

### Licence Details

<b>Licensee</b>	
<b>Licensee Registered Address</b>	
<b>Agreement Number</b>	
<b>Licensed Services</b>	
<b>Additions to Definitions of "Territory"</b>	

# **IMRO Music Downloading Licence**

Date:

**IRISH MUSIC RIGHTS  
ORGANISATION LIMITED BY  
GUARANTEE**

and

---

**L I C E N C E  
A G R E E M E N T**

---

**Cover Sheet**

**IMRO/MCPSI  
LIMITED ONLINE EXPLOITATION  
LICENCE PLUS**

NAME OF LICENSEE	("the Licensee")
COMPANY REGISTRATION NUMBER	
REGISTERED ADDRESS OF LICENSEE	
LICENSED SERVICE	("the Licensed Service")
COMMENCEMENT DATE	("the Commencement Date")
ROYALTY FEE/BAND (in respect of the first 12 months of the Licence)	<i>Insert licence band per service type</i>
<b>SPECIAL CONDITIONS*:</b>  <p>*For the avoidance of doubt, any special conditions included in this section, override the attached terms and conditions to the extent there is any conflict.</p>	

Please tick the relevant licensing scheme(s) you require:

- |   |   |
|---|---|
| <input type="checkbox"/> Music Download                             | <input type="checkbox"/> Music On Demand Karaoke (Subscription) |
| <input type="checkbox"/> Music Download Karaoke                     | <input type="checkbox"/> Webcast (Non-Subscription)             |
| <input type="checkbox"/> Music On Demand (Non-Subscription)         | <input type="checkbox"/> Webcast (Subscription)                 |
| <input type="checkbox"/> Music On Demand (Subscription)             | <input type="checkbox"/> Interactive Webcast (Non-Subscription) |
| <input type="checkbox"/> Music On Demand Karaoke (Non-Subscription) | <input type="checkbox"/> Interactive Webcast (Subscription)     |

**Signed on behalf of the Licensee:**

**Name:** \_\_\_\_\_

**Position:** \_\_\_\_\_

**Date:** \_\_\_\_\_

**Signed on behalf of the Mechanical-Copyright Protection Society Ireland Limited ("MCPSI") of Copyright House, Pembroke Row, Lower Baggot Street, Dublin 2, Ireland contracting for and on behalf of itself and as agent of Mechanical Copyright Society Limited ("MCPS") and its various members and its Affiliated Societies:**

**Name:** \_\_\_\_\_

**Position:** \_\_\_\_\_

**Date:** \_\_\_\_\_

**Signed on behalf of the Irish Music Rights Organisation Company Limited By Guarantee ("IMRO") of Copyright House, Pembroke Row, Lower Baggot Street, Dublin 2, contracting on behalf of itself and on behalf of and as agents of its Affiliated Societies:**

**Name:** \_\_\_\_\_

**Position:** \_\_\_\_\_

**Date:** \_\_\_\_\_

## Appendix 1

### STANDARD TERMS AND CONDITIONS

#### 1. Definitions

**"the Act"** means the Copyright and Related Rights Act 2000, as amended from time to time.

**"Agreement"** means these terms and conditions, the Cover Sheet and annexes to the terms and conditions and the application form completed by the Licensee.

**"Associated Society"** means each collecting society (or other body representing rights in Musical Works) with which MCPS and/or IMRO has, from time to time, an agreement under which MCPS and/or IMRO is authorised to grant licences in relation to the other society's (or body's) repertoire for the purpose of this Agreement PROVIDED THAT where such an agreement is only entered into after the commencement of the Term, a collecting society (or other body) shall only be regarded as an "Associated Society" for the purposes of this Agreement with effect from the date of signature of such agreement with MCPS and/or IMRO (as applicable).

**"Associated Society Member"** means any person, firm or company who or which has been notified, from time to time, as being a member of an Associated Society by the relevant Associated Society to MCPS and/or IMRO.

**"Audio-Visual Material"** means any specific presentation of Musical Works in conjunction with images, whether moving or still. For the avoidance of doubt (but without prejudice to the express restrictions contained in this Agreement), the following shall not be treated as Audio-Visual Material for the purpose of this Agreement:

- (a) the fact that ordinary web pages (or equivalent) are visible to the User while the User is listening to music; or
- (b) the fact that the media player used to play the music generates random visual images while the music is playing;

provided, in both cases, that the User would not reasonably be expected to associate the Repertoire Works being played with the images presented or think that there is any deliberate association by the Licensee of the Repertoire Works with such images.

**"Commencement Date"** means the date specified in the Cover Sheet.

**"Commercial Work"** means any Repertoire Work other than:

- (a) one where the Member owning or controlling the copyright in such Repertoire Work has authorised MCPS to license it as so-called production or library music; or
- (b) a Commissioned Work, PROVIDED THAT for the purposes of clauses 3.2 and 4.5, a Commissioned Work shall not be excluded from such definition where the commissioning agreement does not authorise the Licensee to use the Commissioned Work in the context set out in those clauses.

**"Commissioned Work"** means a Musical Work specially and expressly commissioned by the Licensee from composer/writer members of IMRO and/or MCPS

**"Cover Sheet"** means the cover sheet to this Agreement detailing, among other things, the Licensee details and the Licensed Services covered by the Agreement.

**"Data Storage Device"** means any medium on which data can be stored (whether temporarily or permanently) whether existing now or invented in the future.

**"Dramatico-Musical Work"** means any ballet, opera, operetta, musical, musical play or work of a similar nature.

**"Electronic Reporting Format"** means the format set out in Appendix 3. If and when the DDEX format is agreed within the industry, the DDEX format shall replace the format set out in Appendix 3 within 6 months of such agreement unless otherwise agreed between the parties, acting reasonably.

**"Excluded Service"** means any service (or the relevant part of a service) which falls within the scope of any of the following MCPSI/IMRO licensing schemes:

- (a) MCPSI/IMRO Joint Ringtone Licence;
- (b) MCPSI/IMRO Joint Podcasting Licence
- (c) MCPSI Karaoke and MIDI scheme;
- (d) MCPSI Music-on-hold scheme;
- (e) MCPSI Supply of Background Music Services scheme
- (f) MCPSI/IMRO Joint Ringback scheme; or
- (g) MCPSI/IMRO General Entertainment on Demand (GEOD) scheme; or

any other MCPS/IMRO licensing scheme, from time to time.

**"Gross Revenue"** shall have the meaning set out in the Appendix 2B. Broadly, Gross Revenue means all revenue received (or receivable) by the Licensee from Users in consideration of the provision of the Licensed Services and all other revenue received (or receivable) by the Licensee as a result of the provision of the Licensed Services such as, without limitation, advertising and sponsorship fees. For the avoidance of doubt, this is by way of a summary only. The definition of Gross Revenue applicable to this Agreement is the definition set out in Appendix 2B.

**"Initial Period"** means the period commencing on the Commencement Date and ending 12 months thereafter.

**"Interactive Webcast Service"** means a service (or the relevant part of a service), other than an Excluded Service, by which Musical Works are made available to the public via a Network and:

- (a) no permanent or temporary copy of any Musical Work is retained by the User; and
- (b) such service is neither a Webcast Service, a Music Download Service, a Music Download



(Karaoke) Service, Music On Demand Service, a Music On Demand (Karaoke) Service or a Simulcast Service.

**"Karaoke Version"** means Musical Works which are offered in the form of "karaoke" so that the lyrics of the Musical Work appear graphically onscreen as the music plays (but, for the avoidance of doubt, cannot be printed in physical form) or reproduced in any form where the music is not playing.

**"Licensed Services"** means the Music Service(s) set out on the Cover Sheet.

**"Licensee"** means the party set out as such in the Cover Sheet.

**"Limited Download"** means a Musical Work made available to the public via a Network in the form of a download and where such download can only be retained and played by the User upon continued payment by the User of a Subscription Fee.

**"Licensors"** means IMRO and MCPSI.

**"Member"** means:

- (a) in the case of MCPSI, each person, firm or company who or which, from time to time, has appointed MCPS as agent in relation to online exploitation either before or during the Term other than where such person, firm or company has opted not to participate in the licensing scheme pursuant to which this Agreement has been entered into, PROVIDED THAT a member who has so appointed MCPS after the commencement of the Term shall only be regarded as a member for the purposes of this Agreement with effect from the date on which the Member so appointed MCPS; and
- (b) in the case of IMRO, any person, firm or company who or which, from time to time, pursuant to the Articles of Association of IMRO has been admitted either before or during the Term as a member of IMRO other than where such person, firm or company has reserved to himself the relevant rights pursuant to Article 7(cd) of the Articles of Association of IMRO (or other equivalent article), PROVIDED THAT a member who has been so admitted after the commencement of the Term shall only be regarded as a member for the purposes of this Agreement with effect from the date of admission into IMRO.

**"Month"** means a calendar month.

**"Musical Work"** means any musical work (as defined in the Act) and any lyrics or words written to be used with such musical work (if applicable) and, for the purposes of a Karaoke Service only, including in graphical form. It includes any part of such a work.

**"Music Download Service"** means a service (or the relevant part of a service), other than an Excluded Service or a Music Download Karaoke Service, offering Permanent Downloads.

**"Music Download Karaoke Service"** means a service (or the relevant part of a service), other than an Excluded Service, offering Permanent Downloads in the form of Karaoke Versions.

**"Music On Demand Service"** means a service (or the relevant part of a service), other than an Excluded Service or a Music on Demand Karaoke Service whereby a User may receive a Musical Work by streaming on-demand via

a Network (where the time and place at which such Musical Work is received is selected by the User) and/or by way of Limited Download. Any service falling primarily within the foregoing definition but which also includes elements which fall within the definition of Interactive Webcast Service and/or Webcast Service shall be deemed in its entirety to be a Music On Demand Service.

**"Karaoke Exclusions List"** means the list of groupings of Repertoire Works (such as repertoire of significant publishers or significant Associated Societies) that are excluded from being reproduced as or made available to the public as Karaoke Versions of Repertoire Works under this Agreement. This list shall be provided by the Licensors to the Licensee and is subject to change from time to time. The Licensors shall notify the Licensee in writing (which may include email) of any significant changes to the Karaoke Exclusions List throughout the Term of this Agreement

**"Music On Demand Karaoke Service"** means a service (or the relevant part of a service), other than an Excluded Service) whereby a User may receive a Karaoke Version of a Musical Work by streaming on-demand via a Network (where the time and place at which such Musical Work is received is selected by the User) and/or by way of Limited Download. Any service falling primarily within the foregoing definition but which also includes elements which fall within the definition of Interactive Webcast Service and/or Webcast Service shall be deemed in its entirety to be a Music On Demand Karaoke Service.

**"Music Service Provider"** means, the party which, in relation to the Licensed Service, most closely meets the following criteria:

- (a) contracts with the User in relation to the provision of the Licensed Service;
- (b) sets and controls the price the User pays;
- (c) can fully report on all elements of Gross Revenue (including relevant advertising revenues);
- (d) can fully report on all elements of music usage (or can procure such reporting);
- (e) controls how content is offered and bundled within the Licensed Service;
- (f) carries out or authorises, on their instruction, the carrying out of the copyright restricted acts licensed under this Agreement.

**"Music Usage Information"** means the information referred to in the Electronic Reporting Format.

**"Music Videogram"** means any audio-visual production:

- (a) which has as the main feature of the soundtrack thereof a recording of a single Repertoire Work copies of which recording have been or are intended to be released as audio records for sale to the general public; and
- (b) the making of which was carried out by or on behalf of the record company releasing that recording or by or on behalf of the main artist(s) featured in that recording.

**"Music Service"** means a music service listed on the Cover Sheet (and defined in this Appendix 1).

**"Network"** means the internet, a mobile network or any other wired or wireless network.

**"Permanent Download"** means a Musical Work made available to the public via a Network in the form of a download and where such download may be retained by the User on a permanent basis. For the avoidance of doubt, a Permanent Download excludes ringtones.

**"Permitted Excerpts"** refers only to Dramatico-Musical Works and means excerpts where the use of all such excerpts in any Audio-Visual Material complies with all the following limitations:

- (a) the total duration of the excerpts does not exceed 20 minutes;
- (b) the use is not a "potted version" of the Dramatico-Musical Work;
- (c) the use is not or does not cover a complete act of the Dramatico-Musical Work;
- (d) each excerpt is not presented in a "dramatic form" as defined below; and
- (e) as regards ballets specifically devised for television or excerpts from existing ballets, the total duration does not exceed five minutes.

A dramatic form shall be deemed to be created only by a performance in which there is a distinct plot depicted by actors and where the story of the Dramatico-Musical Work and/or its associated words is woven into and carries forward the plot and its accompanying action (a dramatic form shall not, for example, be deemed to be created by the use of costume, scenery, and/or any dance routine merely to provide an acceptable presentation of the work). For the purposes of this paragraph the word "actors" shall include actors, singers, mimics and/or puppets.

**"IMRO"** means Irish Music Rights Organisation whose registered office is at Copyright House, Pembroke Row, Lower Baggot Street, Dublin 2, Ireland

**"Quarter"** means each of the periods from 1st January to 31st March, 1st April to 30th June, 1st July to 30th September, and 1st October to 31st December, throughout the Term.

**"Relevant Party"** means a party which is involved in the provision of the Licensed Services, as set out in clause 14.2.

**"Repertoire Work"** means each Musical Work the relevant copyright in which is owned or controlled, from time to time, in the Ireland by:

- (a) MCPSI or a Member or an Associated Society or an Associated Society Member PROVIDED THAT (i) if one or more of those who own or control the copyright in a relevant Repertoire Work is not MCPS or a Member or an Associated Society or Associated Society Member, the expression "Repertoire Work" shall only apply to such interest in the Repertoire Work as is owned or controlled by MCPS or the Associated Society or the relevant Member or Associated Society Member, and (ii) it shall exclude any Musical Works that a Member of MCPS or an Associated Society has withdrawn or withheld from this Agreement; and

- (b) IMRO or a Member or an Associated Society or an Associated Society Member PROVIDED THAT if one or more of those who own or control the copyright in a relevant Repertoire Work is not IMRO or a Member or an Associated Society or Associated Society Member, the expression "Repertoire Work" shall only apply to such interest in the Repertoire Work as is owned or controlled by IMRO or the Associated Society or the relevant member or Associated Society Member.

Details of major groupings of repertoire (such as repertoire of significant publishers or significant Associated Societies) that are excluded from the Repertoire Works licensable under this Agreement (as at the date of this Agreement) are set out in Appendix 4 to this Agreement. This list is subject to change from time to time and the Licensors shall notify the Licensee in writing (which may include email) of any further inclusions or exclusions of any such major groupings of repertoire throughout the Term of this Agreement.

For the avoidance of doubt, if a Musical Work is a Repertoire Work in relation to one Licensor and not the other then it remains a Repertoire Work under this Agreement in relation only to the licence granted by that Licensor, and the applicable split between mechanical and performing rights in the United Kingdom from time to time shall be used to evaluate the licence fee payable.

**"Renewal Period"** shall mean each additional consecutive 12 month period after the expiry of the Initial Period.

**"Royalty Fee"** means the royalties payable in accordance with clause 5 as set out in Appendix 2A in respect of the calendar year 2017.

**"Server Territory"** means the European Economic Area, Switzerland, the United States of America, Canada and such other territories as may be agreed in writing by the parties.

**"Simulcast Service"** means the broadcast (as that term is defined in the Act as at 1 July 2006) of a programme via a Network where such broadcast:

- (a) is simultaneous with the broadcast of such programme via a traditional terrestrial, satellite or cable television or radio service; and
- (b) is made from the website or other service of the originating broadcaster.

**"Subscriber"** means a User who accesses a Licensed Service by means of a payment allowing access for a limited period of time (i.e. while the subscription continues) and in respect of which there would ordinarily be a subscription fee payable (a **"Subscription Fee"**).

**"Term"** means the Initial Period plus any Renewal Period (unless terminated earlier under clauses 4.6, 12.1, 12.3, 12.4 or 12.5).

**"Territory"** means Ireland.

**"User"** means a natural person in the Territory who receives the Licensed Services for their own private and non-commercial use.

“**VAT**” means value added tax and each like tax imposed in addition to or in substitution therefore.

“**Voucher**” means a physical or online voucher or token which is pre-paid and allows a User to redeem that pre-payment against purchase of music from the Licensed Service.

“**Webcast Service**” means a service (or the relevant part of a service), other than an Excluded Service or a Simulcast Service, by which Musical Works are broadcast (as that term is defined in the Act as at 1 July 2006) to Users via a Network. For the avoidance of doubt, to constitute a Webcast Service, there must be:

- (a) no interactive functionality, for example (without limitation), no use of controls that enable the User to pause, skip, move forward or backwards through the stream;
- (b) no personalisation of the service by the User or the ability for the User to offer preferences which then dictate the tracks that are provided to that User, for example (without limitation), no ability for the User to rate tracks so as to influence subsequent tracks that are played;
- (c) no advanced notification to the User of titles of specific tracks to be played or specific albums from which tracks will be played (other than the introduction of the next track in DJ led services);
- (d) in any 3 hour period:
  - (i) no more than 3 songs from a particular album (including no more than 2 consecutively);
  - (ii) no more than 4 songs from a particular artist or from any compilation of tracks (including no more than 3 consecutively);
- (e) no archived programmes less than 5 hours in duration or available for more than 2 weeks; and
- (f) no continuous programmes of less than 3 hours duration; and
- (g) effective technologies, insofar as such technologies are commercially available and can be implemented without imposing unreasonable costs, which aim to prevent:
  - (i) a User or any other person or entity from automatically scanning the Licensee’s transmissions alone or together with transmissions by other transmitting entities in order to select a particular sound recording to be transmitted to the User; and
  - (ii) a User from making copies, other than transient copies, of the sound recordings; and
- (h) no automatic or intentional cause by the Licensee of the device receiving a transmission to switch from one program channel to another.

## 2. Grant of Licence

2.1 Subject to and conditional upon compliance with the terms and conditions contained herein and in particular subject to the exclusions and restrictions set out in clauses 3 and 4, MCPSI grants the Licensee

a non-exclusive licence to do the following during the Term:

- (a) to reproduce Repertoire Works on servers within the Server Territory (including temporary copies on servers between the originating server and the ultimate destination of the Repertoire Work) for the purpose of transmitting the same to Users (for the User's own private and non-commercial use) by means of the Licensed Services; and
- (b) where downloads are permitted under this Agreement, to cause temporary or permanent copies (as applicable) of Repertoire Works to be made on Users’ Data Storage Devices in the Territory for the User's own private and non-commercial use.

For the avoidance of doubt (but subject to all terms of this Agreement, in particular clause 3.4), it is intended that this Agreement licenses all reproductions of Repertoire Works necessary in the ordinary operation of the Licensed Services.

2.2 Subject to and conditional upon compliance with the terms and conditions contained herein and in particular subject to the exclusions and restrictions set out in clauses 3 and 4, IMRO grants the Licensee a non-exclusive licence, during the Term, to make available to the public (as that term is defined in section 40 (1) (a) (but not for the avoidance of doubt Section 40 (1) (b) – (g) inclusive of the Act) and to authorise the making available to the public of Repertoire Works within the Territory solely as part of and for the purposes of the provision of the Licensed Services.

2.3 The above licences shall apply where Repertoire Works are used in audio-only material and, subject to clause 3.2, Audio Visual Material.

2.4 The Licensors will not unreasonably refuse or delay any request by the Licensee to include further services of the Licensee within the scope of this Agreement provided that:

- (a) they are a Music Service; and
- (b) the Licensee is, in relation to that service, the Music Service Provider; and
- (c) they are otherwise within the scope and limitations set out in this Agreement.

2.5 The provisions of clauses 3.2, 3.6, 4.1, 4.2, 4.4 and 4.5 shall not apply to a particular Repertoire Work where the owner of the relevant rights in such Repertoire Work has granted permission to the Licensee for the use of that Repertoire Work on the Licensed Services in the manner described under the relevant clause on such terms and conditions (including, if required, the payment of royalties or fees in addition to those specified under this Agreement) as the owner thinks fit.

2.6 The licences granted in clauses 2.1 and 2.2 shall not apply to any Licensed Service which knowingly or recklessly provides internet or mobile “links” to music which requires a licence, but is unlicensed (whether in the form of recordings or notation, scores, lyrics, etc). The inclusion of such links on a Licensed Service shall constitute a material breach of this Agreement (which is capable of remedy).

### 3. Exceptions and Limitations

- 3.1 The licences granted under clause 2 are valid only insofar as:
- (a) the Licensed Services are Music Services. Should the Licensee offer or wish to offer modified or additional services that are not Music Services under this Agreement but which require a licence for the use of Repertoire Works the Licensee shall immediately notify the Licensors and provide such further information as the Licensors may reasonably request; and
  - (b) the Licensee is the Music Service Provider in relation to the Licensed Services
  - (c) the Licensed Services are provided solely in the Territory and not in any additional countries. Should the Licensee wish to provide the Licensed Services in any additional country outside of the Territory the Licensee shall immediately notify the Licensors and provide such further information as the Licensors may reasonably request.
- 3.2 Subject to clause 2.5, the incorporation of Commercial Works into Audio-Visual Material is only licensed under this Agreement where the Audio-Visual Material consists of:
- (a) a Music Videogram; or
  - (b) a live concert performance or a film of a live concert performance by the artist performing that particular Commercial Work; or
  - (c) subject to clause 4.5, such Commercial Works being combined with photographs or other images relating to the artist performing the Commercial Work or the composer of the Commercial Work; or
  - (d) subject to clause 4.5, an interview with an artist, composer, producer or other person involved in the creation, performance or production of music where the Commercial Work(s) used are associated with the interviewee(s); or
  - (e) where permitted under clause 4.1, a performance of Permitted Excerpts of the Dramatico-Musical Work of which the Commercial Work forms part.
- For the avoidance of doubt, such Audio-Visual Material as is licensed under 3.2(a) to (e) above is only licensed insofar as it is reproduced or made available to the public via the Licensed Services.
- 3.3 For the avoidance of doubt, this Agreement does not grant any "synchronisation licence" (to the extent that such a licence may be required by the Licensee) covering the initial fixation of Repertoire Works in combination with visual images to create and produce Audio-Visual Material.
- 3.4 For the avoidance of doubt, the licences granted under clause 2 shall not authorise the manufacture or distribution of physical products containing Repertoire Works, such as (without limitation) the ordering of compact discs (or any other type of physical media) via the Licensed Service, but which are distributed by mail.
- 3.5 For the avoidance of doubt, the licences granted under clause 2 shall not extend to the public performance (as that term is used in the Act) of Repertoire Works, whether as part of the Licensed Services or otherwise.
- 3.6 Subject to clause 2.5, the licence granted under clause 2.1 shall not permit the use of Repertoire Work(s) with any advertising or sponsorship of whatsoever nature where:
- (a) such Repertoire Work(s) are incorporated into such advertising or sponsorship; or
  - (b) such Repertoire Work(s) are otherwise presented in such a way that a reasonable person might associate the Repertoire Work(s) with the advertising or sponsorship.
- 3.7 For the avoidance of doubt (but without prejudice to the generality of clause 3.6), the licences granted under clause 2 shall not apply to any Repertoire Work(s) made available for the purpose of (whether in whole or in part):
- (a) directly or indirectly encouraging the User to purchase or obtain goods or services of whatsoever nature (other than music via the Licensed Service); or
  - (b) promoting the branding of the Licensee, any affiliate of the Licensee or any third party;
- in such a manner that:
- (i) one or more particular Repertoire Works, composers or writers are associated with such promotion; or
  - (ii) a reasonable person might assume that there was an association between particular Repertoire Works, composers or writers and such promotion.
- 3.8 Except where expressly agreed otherwise in writing between the parties, the licences granted under clause 2 shall not apply to graphic copies (meaning, without limitation, copies of lyrics (except in the case of a Karaoke Service licensed hereunder), notation or scores) of Repertoire Works.
- 3.9 Subject to the provisions of this clause 3.9, the licence granted under clause 2.2 shall apply to the communication to the public of Repertoire Works within the Licensed Service including where such communication to the public is not as part of a music download, stream or webcast constituting the substantial offering of the Licensed Service. However, the licence granted under clause 2.2 only applies if all of the following conditions are met:
- (a) the Licensee has the benefit of a valid licence for or a right to make a reproduction of that particular Repertoire Work and for that particular form of exploitation via the Licensed Service either pursuant to this Agreement or otherwise; and
  - (b) the licence of the communication to the public of such Repertoire Work is not otherwise excluded under the terms of this Agreement; and

- (c) the Licensors and the Licensee have agreed the additional fee that shall be payable in respect of such communication to the public and that fee has been paid by the Licensee to the Licensors.

By way of example only, the licence granted by MCPSI under clause 2.1 does not cover the copying of Repertoire Works in an advertisement (see clause 3.6 above). However, clause 3.6 does not apply to the licence granted by IMRO under clause 2.2. Therefore, pursuant to this clause 3.9, the licence granted by IMRO under clause 2.2 would only apply (in the context of this example) if the Licensee has a licence to copy the Repertoire Work for use in that advertisement (and on the Licensed Service(s)) and if the Licensee has paid the agreed fee to the Licensors.

- 3.10 For the avoidance of doubt, this Agreement grants no licence whatsoever in relation to Repertoire Works which are made available by the Licensee outside of the Licensed Service (or outside the scope of this Agreement).

However, such other exploitation of Repertoire Works may fall within the scope of other licensing schemes operated by the Licensors, details of which shall be made available to the Licensee on request.

- 3.11 For the avoidance of doubt, the licences granted under clause 2 shall not extend to any exploitation on a Licensed Service from recordings which are themselves infringing copies.
- 3.12 Certain Repertoire Works, as detailed in the Karaoke Exclusions List, are excluded from being reproduced into and/or made available to the public as Karaoke Versions of the Repertoire Works. This Agreement grants no licence in respect of Repertoire Works or groupings of Repertoire Works appearing on the Karaoke Exclusions List

#### 4. Further Restrictions

- 4.1 Subject to clause 2.5, where any Repertoire Work forms part of any Dramatico-Musical Work, the licence granted under clause 2.1 shall not apply, in relation to Audio-Visual Material, to the reproduction of:

- (a) the whole Dramatico-Musical Work; or
- (b) any excerpt(s) from such Dramatico-Musical Work unless all of the following circumstances apply:
  - (i) that which is copied or made available to the public via the Licensed Services under this Agreement contains only excerpt(s) within the definition of Permitted Excerpts; and
  - (ii) neither of the Licensors has notified the Licensee in writing that their Member or the Associated Society Member objects to the reproduction of any such Repertoire Work.

- 4.2 Subject to clause 2.5, where any Repertoire Work forms part of any Dramatico-Musical Work, the licence granted under clause 2.1 shall not apply, in relation to material other than Audio-Visual Material, to the reproduction of the whole or substantially the whole Dramatico-Musical Work unless:

- (a) the Licensee has specifically notified the Licensors that it wishes to reproduce the whole or substantially the whole work; and
- (b) the Licensors have notified the Licensee that all relevant Members consent to such reproduction.

For the purposes of this clause 4.2, the expression "Dramatico-Musical Work" shall include any version of such work (with or without cuts, additions, interpolations or the like) which has been publicly performed. Furthermore, for the avoidance of doubt, substantially the whole work shall be deemed to be reproduced where all or nearly all the individual songs or other music included in the work are reproduced.

- 4.3 In any event, any licence hereunder only applies to the relevant Repertoire Works and not (by way of example only) to any underlying dramatic or literary work which forms part of the Dramatico-Musical Work or which such Dramatico-Musical Work is based on or uses.

- 4.4 Subject to clause 2.5, the licences granted under this Agreement shall not extend to or permit any adaptation of any Repertoire Work to be copied or made available to the public as part of a Licensed Service unless the relevant Member has consented to such adaptation. By way of example only, this applies to:

- (a) any sampling (meaning the taking of part of the music and/or lyrics of a Repertoire Work and incorporating such part into another Musical Work) or the communication to the public or reproduction in the form of a sample of such part of a Repertoire Work; or
- (b) using with music lyrics other than those written to be used with the music or authorised for use with the music; or
- (c) using with lyrics music other than that written to be used with the lyrics or authorised for use with the lyrics.

However, subject always to clause 4.10 and provided that such alterations do not amount to an adaptation of a Repertoire Work and do not contravene clause 4.5, then this Agreement shall apply in relation to Repertoire Works that have been modified (including music and/or lyrics) for the purpose of satisfying the requirements of the relevant recording.

For the avoidance of doubt, the Licensors acknowledge, for the purposes of the restriction set out in this clause 4.4, that the production and inclusion as part a Music Download Service of audio clips of Repertoire Works of up to 30 seconds duration (or up to 1 minute's duration for Repertoire Works over 6 minutes in length) to promote the supply of music via Music Download Service does not of itself constitute an adaptation or sample.

- 4.5 Subject to clause 2.5, the licences granted under this Agreement shall not extend to:

- (a) the reproduction or communication to the public of any Commercial Work or part thereof in the form of a parody or burlesque of any Commercial Work or of any composer or

writer of any Commercial Work or any band or other group of artists which includes any composer or writer of any Commercial Work; or

- (b) the use of any Commercial Work in any context which the Licensee ought reasonably to consider as being likely to be insulting or detrimental to the composer featured on the commercially released sound recording of the music or the relevant Member or Associated Society Member.

- 4.6 Any additional limitations in relation to the Associated Societies' rights to grant the licences set out in clause 2 which have been notified to the Licensors shall be notified to the Licensee in writing (which may include by email) and shall be binding no less than 10 days following such notice. Where any restriction of a material nature is added (other than exclusions of Musical Works from the definition of Repertoire Works), the Licensee shall have the right to terminate this Agreement by giving written notice to the Licensors.
- 4.7 All rights not specifically granted under this Agreement are hereby reserved.
- 4.8 This Agreement only covers Repertoire Works. It does not extend to other rights or interests, including (by way of example only), rights in sound recordings, films, dramatic works, performers' rights or rights in performances. The Licensee is required to obtain the appropriate waivers, consents and/or licences from the person(s) owning or controlling rights in relation to sound recordings containing Repertoire Works or performers of that Repertoire Work.
- 4.9 It is the responsibility of the Licensee to obtain all necessary licences in relation to any Musical Work which is not, or to the extent that it is not, a Repertoire Work, and no licence is granted under this Agreement in relation thereto.
- 4.10 Nothing in this Agreement affects the moral rights of authors of Repertoire Works whether subsisting in the Ireland or any other territory.

## **5. Fees and Payment**

- 5.1 In consideration of the licences and authorisations granted under this Agreement, the Licensee shall pay to the Licensors the Royalty Fees for the duration of the Term.
- 5.2 The Royalty Fees for the Initial Period and for each Renewal Period thereafter shall be payable during each 12 month period of the Term in four equal quarterly instalments. Each instalment shall be payable in advance on the first day of each the Quarter by direct debit, or as otherwise agreed by the Licensors.
- 5.3 The Licensors shall be entitled to increase the Royalty Fees at the start of each calendar year based on the annual increase in the Retail Price Index over the preceding year. The increased Royalty Fees will be notified to the Licensee prior to the end of the Initial Period and each applicable Renewal Period and will apply to the Licensee from the start of the Renewal Period.
- 5.4 The Licensee may at any time during the Term change from a lower Royalty Fee band to a higher

Royalty Fee band within a particular Music Service by paying the difference between the lower Royalty Fee band already paid and the higher Royalty Fee band. The Licensee may not change from a higher Royalty Fee band to a lower one and the Licensors shall not refund the Licensee in the event that the Licensee's actual exploitation of Repertoire Works is such that the Licensee would be eligible for a lower Royalty Fee band but has paid the Royalty Fee for a higher band.

- 5.5 The Royalty Fees shall be cumulative and for any service which combines more than one Music Service, an aggregate Royalty Fee shall be payable.
- 5.6 Each Musical Work on an album made available to the public shall be counted as a single download for the purpose of the usage limits in Royalty Fee band.
- 5.7 The Licensee shall notify the Licensors immediately if the Licensee exceeds the maximum usage limit in the highest Royalty Fee band in any one Music Service. If the maximum usage limit is exceeded, this Agreement shall terminate and the Licensee shall contact the Licensors to discuss the appropriate licence applicable to the Licensee.
- 5.8 The Licensee shall notify the Licensors immediately if the Licensee exceeds the maximum usage limit in the Royalty Fee band for which the Licensee applied. The Licensee shall then pay the difference between the Royalty Fee band for which he applied and the Royalty Fee band for which the Licensee's usage actually falls within.
- 5.9 At the end of the Initial Period and each Renewal Period during the Term the Licensee shall provide a report to the Licensors detailing the number of Musical Works made available to the public under the Licensed Service. In the event that such number is greater than the maximum number permitted under the Royalty Fee band for which the Licensee applied the Licensee shall pay the difference between the Royalty Fee band for which he applied and the Royalty Fee band for which Licensee's usage actually falls within.
- 5.10 The Licensee shall notify the Licensors if the Gross Revenue from the Licensed Services exceeds the sum of €200,000 (excluding VAT) per annum. In such circumstances, this Agreement shall terminate and the Licensee shall contact the Licensors to discuss the appropriate licence applicable to the Licensee.
- 5.11 The Licensee shall notify the Licensors immediately if the Licensee is to launch a new service which constitutes a Music Service and therefore requires a licence from the Licensors. The Licensee shall submit to the Licensors a fully and accurately completed application for licence 28 days before the launch of any such new service.
- 5.12 The Licensee shall notify the Licensors promptly of any material change in the information provided in the application for licence and the effective date of such change.
- 5.13 All Royalty Fees and payments referred to in this Agreement are subject to VAT or other equivalent sales tax. The Licensee shall pay to the Licensors VAT or other equivalent sales tax (if applicable) at the rate or rates from time to time in force on any sums payable under this Agreement.

5.14 Without prejudice to any other right or remedy of the Licensors, and without imposing an obligation to accept late payment, where any fees payable under this Agreement are not paid by the due date (or the date on which such fees should ordinarily have been paid in circumstances where the Licensors have been unable to submit an invoice) due to default of the Licensee, the Licensee shall (if required by the Licensors) pay interest on such late payment calculated on a daily basis at an annual rate of 3% over the base rate, current from time to time, of Bank of Ireland payable from the date on which the payment should have been made to the date on which the payment was made.

5.15 Except as expressly set out in these terms and conditions, no deduction in respect of any tax, or any other deduction or set-off of whatsoever nature, shall be made in calculating or paying any sum due under this Agreement.

## 6. Supply of Information

6.1 In relation to any and all Repertoire Works reproduced and made available to the public under this Agreement via all Licensed Services, the Licensee will deliver the Music Usage Information to the Licensors or to the Licensors' duly authorised agent (details of which will be provided to the Licensee) in the Electronic Reporting Format quarterly one month following the Quarter to which the Music Usage Information relates.

6.2 The Licensee must also supply the Licensors with any further information or documentation in its possession, power, custody or control (and use its reasonable endeavours to supply the Licensors with any further information or documentation not in its possession, power, custody or control) reasonably requested by the Licensors at any time, in order to enable the Licensors to verify the Repertoire Work(s) which have been reproduced or distributed via all Licensed Services.

6.3 Where any or all of the Licensed Services are accessible by Users only on payment of subscription or other similar payment (or access is otherwise limited or controlled in some way), the Licensee shall, upon request of the Licensors, use reasonable endeavours to ensure that such Licensed Services are at all times accessible by the Licensors (and IMRO for Music) free of charge for the purposes of the Licensors verifying that the Licensee is acting in accordance with this Agreement. For the avoidance of doubt, the Licensee shall not be required to provide free access to downloads under a Music Download Service or to provide free access to a mobile phone network or internet access.

6.4 The Licensee acknowledges that the Licensors have a responsibility to maximise the efficiency of their reporting to their Members and the Associated Societies. Therefore, if the Licensors wish to make any reasonable upgrade or alteration of whatsoever nature to the Music Usage Information or data specification referred to in Appendix 3 during the Term, the Licensee agrees to use its reasonable endeavours to implement the changes required as soon as is reasonably practicable, PROVIDED THAT the Licensors shall not request that the Licensee implements the change in less than six months from the making of the request, and in each case of a change the following procedures shall apply:

- (a) the Licensors shall give full details thereof in writing to the Licensee;
- (b) the Licensee will respond in writing within 4 weeks of receipt of the request, stating the date by which it commits to comply with the change and the Licensors shall provide full assistance to the Licensee in order to assist the Licensee in complying with the change; and

the parties will then finalise the details and undertake tests to ensure that the change operates satisfactorily within the terms of this Agreement, satisfactory operation of which will be deemed acceptance of the change and Appendix 3 and/or the definition of Music Usage Information will be amended or replaced accordingly. For the purpose of this clause, in determining what change may be reasonable, regard shall be had to the DDEX project.

6.5 Without prejudice to any right in law that the Licensors may have to obtain such information, the Licensee shall not be obliged to provide to the Licensors any information which identifies Users or which otherwise constitutes "personal data" as defined in the Data Protection Act 1998. For the avoidance of doubt, the Licensee must still provide all required Music Usage Information (or other information to be provided under this Agreement), but is entitled to remove any element of it which reveals the identity of Users or otherwise causes it to include or constitute "personal data".

## 7. Late Reporting

7.1 The following provision applies where the Licensee has:

- (a) failed to deliver prior to the required date Music Usage Information for the Licensed Service; or
- (b) delivered such Music Usage Information prior to the required date, but it contains any omission or error of whatsoever nature (by way of example only, Repertoire Works having been omitted therefrom or incorrectly or misleadingly named, or the duration of any Repertoire Works having been under-reported) which is material and the Licensee has failed to give notice in writing to the Licensors correcting the omission or error by the date upon which such reporting should have been provided.

7.2 In such circumstances (and without prejudice to any other rights which either or both Licensors may have against the Licensee) if one or both of the Licensors has distributed some (or all) royalties received (excluding any commission) to Members and/or Associated Societies based on the usage data supplied, but, as a result of clause 7.1(a) or (b) applying, the royalties distributed do not accurately or fairly represent that which each of the Members and/or Associated Societies should have received (when considering the true usage of Repertoire Works), then the Licensee shall pay the fees set out in clauses 7.3 and 7.4 (in addition to those set out in clause 5).

7.3 Where clause 7.2 applies, separately in relation to each relevant Repertoire Work either omitted from the relevant Music Usage Information or as regards

which there was a material omission or error of whatsoever nature or in relation to which the relevant Music Usage Information was not delivered, the additional fees shall be calculated at the rate equivalent to that which has been or will be paid by MCPS and/or IMRO (as applicable) to their members (or associated societies) in relation to the Music Usage Information which was submitted prior to the required date.

7.4 Where clause 7.2 applies, the Licensee will also pay interest on the additional fees as referred to in clause 7.3 above computed in accordance with clause 5.14 and calculated from the date on which MCPSI and/or IMRO (as applicable) first made a distribution to their members (or associated societies) in relation to the relevant period to the date on which the Music Usage Information was received by the Licensors or the date on which the Licensors received written notice of the relevant error, as the case may be.

7.5 The provisions of this clause apply notwithstanding any other provision of this Agreement, but are without prejudice to any other right which MCPSI and IMRO have in relation to any failure to submit Music Usage Information fully or accurately completed within the time stipulated in clause 6.1.

## 8. Vouchers

The licence under clause 2.1 only applies to Licensed Services purchased using Vouchers where each such Voucher:

- (a) either:
  - (i) contains no branding other than that of the Licensee; or
  - (ii) is issued in conjunction with a festival or other musical event, and the voucher contains no branding other than that of the Licensee, the band/artist performing at the festival or other musical event, and/or the festival or other musical event;and in the case of either (i) or (ii) above:
- (b) does not refer to any specific artist(s), band(s) or Musical Work(s); and
- (c) does not otherwise contravene the limitations and restrictions set out in this Agreement (in particular clause 3.6 and 3.7).

Repertoire Works provided via a Voucher scheme which is outside this clause 8.1 are not licensed under this Agreement and a separate licence for premium usage of this type must be sought from the Licensors.

## 9. Credits and Notices

The Licensee shall include on each of the Licensed Services:

- (a) the logo of IMRO; and
- (b) details of the following website and, where practical, hypertext links to it: [www.imro.ie](http://www.imro.ie); and

- (c) where reasonably practicable, the name of the composer and publisher of the Repertoire Works provided via the Licensed Services; and
- (d) a notice explaining that use of the musical works is subject to restrictions and that a summary of these restrictions may be obtained by accessing the Licensors' website through the link referred to above.

Approval of the Licensors shall be deemed to be given to the positioning of the above credits and notices within the terms and conditions of the Licensed Service(s) where it is not reasonably practical to position such information elsewhere.

## 10. Auditing

10.1 The Licensee shall keep and make available for inspection upon reasonable notice (and shall procure that each Relevant Party keeps and makes available for inspection upon reasonable notice), both during and for twelve months after termination or expiry of this Agreement, proper, detailed books and records relating to (a) the use of all Musical Works and (b) any income or other consideration received by or on behalf of the Licensee in relation to the Licensed Services, together with any supporting documentation relating thereto covering the period up to six years prior to the date of notification of audit. Where any agreement between the Licensee and the Licensors replaces this Agreement or licenses substantially the same activities (the "**Replacement Agreement**"), the twelve month time-limit referred to above shall begin following termination or expiry of the Replacement Agreement.

10.2 For the purposes of this clause 10, the Licensee shall allow upon reasonable notice (and shall procure that each Relevant Party shall allow) access to its premises to inspect relevant accounting records, but not more than once per annum. The duly authorised representatives (who shall be external qualified accountants or auditors unless otherwise agreed between the parties) of the Licensors shall have such access to the Licensee's premises and shall be entitled to inspect, make extracts and take copies of any of the information and/or documentation available and to carry out such work as is, in their reasonable opinion, considered necessary to verify compliance with the provisions of this Agreement.

10.3 If tests under any audit and verification process indicate under-payment of the correct Royalty Fee during the period under audit, then, without prejudice to the Licensors' other rights under this Agreement, the Licensee shall pay the amount of the underpayment plus interest based on the period from which the correct fee should have been paid to the Licensors to the date when it was actually paid (at the rate set out in clause 5.14).

10.4 If any audit and verification process discloses (a) under-payment of more than 7.5% of the correct Royalty Fee during the period under audit and/or (b) failures to report correctly (so as to affect a distribution by the Licensors to their Members) amounting to at least 7.5% of the music usage during the period under audit, then, without prejudice to the Licensors' other rights under this Agreement, the Licensee shall pay, in addition to



the payment referred to in clause 10.3, the Licensors' reasonable costs of such audit and verification within 28 days of receipt of the Licensors' VAT invoice therefore.

10.5 If tests under any audit and verification process indicate over-payment of the correct Royalty Fee during the period under audit, then the Licensors shall, as soon as is reasonably practical, pay the amount of the overpayment back to the Licensee (but, for the avoidance of doubt, no interest shall be payable unless the overpayment is a result of an act or omission of the Licensors (in which case interest shall be payable at the rate set out in clause 5.14)). However, where the overpayment does not result from an act or omission of the Licensors and the Licensors have already distributed such overpayment to their Members and/or Associated Societies, the Licensors shall be entitled to deduct its reasonable internal and/or external costs in administering the payment back of the overpayment.

10.6 The Licensors shall not (and shall procure that their representatives shall not), without the Licensee's written consent, disclose to any third party any confidential information of the Licensee (so long as it remains confidential) received in the course of an audit carried out under this clause 10, save that such confidential information may be disclosed to the Licensors' directors, board sub-committee members, officers, employees and professional advisors (solely where such persons are under a duty of confidentiality in relation to information so received and the Licensors shall be liable to the Licensee in respect of any breach of such confidentiality obligation) solely for purposes connected with this Agreement.

10.7 For the avoidance of doubt, books, records and accounting records as referred to in clauses 10.1 and 10.2 above shall include data, information and records held on computers.

10.8 The Licensee shall, if requested by the Licensors, provide a statement from its auditors (but not more than once per year) confirming that the financial information submitted by the Licensee for the relevant requested period is in accordance with the actual Gross Revenue for that period.

## 11. Security and Encryption

Save as may be permitted by law, the Licensee agrees it shall not (and shall procure that any Relevant Party shall not) attempt to:

- (a) remove or alter any rights management or identifier information that may be associated with any Repertoire Works; or
- (b) circumvent any technical measures associated with any Repertoire Work which are designed to prevent or restrict the unauthorised use of any Repertoire Work.

## 12. Termination and Expiry

12.1 Subject to payment of the Royalty Fee to the Licensors, this Agreement shall automatically renew for a period of 12 months after the end of the Initial Period and at the end of each subsequent Renewal Period until either party gives to the other party not less than three months prior written notice that it does not wish for the Agreement to automatically

renew, in which event the Agreement shall terminate at the end of the relevant Renewal Period.

12.2 This Agreement may be terminated by the Licensee, by giving not less than three months written notice to the Licensors or upon written notice in circumstances where the Licensee is ceasing to engage in activities covered by this Agreement. In the event that the Licensee terminates the Agreement pursuant to this clause 12.2, the Licensee shall not be entitled to any refund of Royalty Fees, however, subsequent Quarterly instalments of the annual Royalty Fee relating to Quarters falling after the Agreement terminates shall not be payable.

12.3 Each party shall have the right to terminate this Agreement by notice forthwith where the other party:

- (a) commits a material breach of this Agreement which is capable of remedy and fails to remedy such breach within 14 clear days after receipt of notice of such breach; or
- (b) commits a material breach of this Agreement which is not capable of remedy;

and, for the avoidance of doubt, any breach which consists of a failure by either party to perform an obligation under this Agreement within any period required or by any date specified under this Agreement shall be deemed to be capable of remedy if such obligation is performed by such party within the 14 day cure period specified in (a) above.

12.4 The Licensors shall have the right to terminate this Agreement by notice forthwith if the Licensee:

- (a) is dissolved (other than pursuant to a consolidation, amalgamation or merger);
- (b) becomes insolvent or is unable to pay its debts or fails or admits in writing its inability generally to pay its debts as they become due;
- (c) makes a general assignment, arrangement or composition with or for the benefit of its creditors;
- (d) institutes or has instituted against it a proceeding seeking a judgment of insolvency or bankruptcy or any other relief under any bankruptcy or insolvency law or other similar law affecting creditors' rights, or a petition is presented for its winding-up or liquidation, and, in the case of any such proceeding or petition instituted or presented against it, such proceeding or petition:
  - (i) results in a judgment of insolvency or bankruptcy or the entry of an order for relief or the making of an order for its administration, winding-up or liquidation; or
  - (ii) is not dismissed, discharged, stayed or restrained in the case of a winding-up petition within 14 days or in the case of an administration petition within 2 days, of the institution or presentation thereof;

- (e) has a resolution passed for its winding-up, official management or liquidation (other than pursuant to a consolidation, amalgamation or merger);
- (f) seeks or becomes subject to the appointment of an administrator, provisional liquidator, conservator, receiver, trustee, custodian or other similar official for it or for all or substantially all its assets;
- (g) has a secured party take possession of all or substantially all its assets or has a distress, execution, attachment, sequestration or other legal process levied, enforced or sued on or against all or substantially all its assets and such secured party maintains possession, or any such process is not dismissed, discharged, stayed or restrained, in each case within 30 days thereafter; or
- (h) causes or is subject to any event with respect to it which, under the applicable laws of any jurisdiction, has an analogous effect to any of the events specified in clauses (a) to (g) (inclusive).

12.5 The licences granted under clause 2 are so granted on the basis of the representations made by the Licensee in part A of the application form.

12.6 The Licensors shall have the right to terminate this Agreement by notice forthwith if the licences granted under clause 2 are no longer valid pursuant to clause 3.

12.7 Termination of this Agreement for whatever reason shall be without prejudice to any rights which have already accrued to the parties under this Agreement.

### 13. Effect of Termination

13.1 Upon termination of this Agreement all licences granted under this Agreement shall terminate and the Licensee shall immediately cease to be licensed by the Licensors for the reproduction or communication to the public of Repertoire Works via the Licensed Services. Termination shall be without prejudice to the ability of Users to retain a copy of a Repertoire Work supplied to them in the form of a Permanent Download.

13.2 Clauses 5, 6, 7, 10, 13, 16 and 17 shall survive the termination of this Agreement, but only in relation to the Licensee's activities during the Term.

### 14. No Assignment

14.1 Subject to clause 14.2, the licences granted under this Agreement are personal to the Licensee and the Licensee may not assign, sub-license or otherwise transfer any or all of its rights or obligations under this Agreement without the written agreement of both MCPSI and IMRO except where the Licensee wishes to assign or transfer its rights and obligations to a direct or indirect subsidiary or direct or indirect holding company of the Licensee in which case the Licensors may not unreasonably withhold consent.

14.2 Subject always to the other provisions of this Agreement, the Licensee shall be permitted to use the services of a third party in operating the Licensed Services, provided that:

- (a) the Licensee retains complete control and direction over the provision of the Licensed Services to Users; and
- (b) the Licensors are able to audit such third party in accordance with clause 14.

14.3 The Licensee shall include the following provisions in its terms and conditions for the supply of the Licensed Services to Users:

- (a) that any Repertoire Works made available to Users may only be copied as permitted under this Agreement or by applicable law; and
- (b) that, save as may be permitted by law, no attempt shall be made by Users to:
  - (i) remove or alter any rights management or identifier information that may be associated with any Repertoire Works; or
  - (ii) circumvent any technical measures associated with any Repertoire Work which are designed to prevent or restrict the unauthorised use of any Repertoire Work.

14.4 The Licensee shall, upon request by either Licensor, supply such Licensor forthwith with a copy of the Licensee's standard terms and conditions applying to the provision of any or all of the Licensed Services.

### 15. Controlled Composition Agreements

Where any person, firm or company is or becomes a member of either of the Licensors or an Associated Society and that party itself or that party's predecessor in title or grantor has a current contract with the Licensee or the Licensee's predecessor in title or grantor:

- (a) to the extent that such contract would otherwise apply in relation to the grant of any or all of the licences referred to in this Agreement and/or the terms and conditions on which such licences are granted, the terms and conditions of this Agreement shall during the subsistence of this Agreement replace the terms and conditions of that contract; and
- (b) upon the written request of the Licensee the relevant Licensor will provide the Licensee with evidence that the relevant Member has become a Member and has given the relevant Licensor or the relevant Associated Society authority to bind the Member as regards this Agreement.

This clause does not prevent the Licensee from obtaining a licence only in relation to the rights referred to in clause 2.1 from the relevant party owning or controlling such rights where such licence is validly obtained whether before or after the Commencement Date but other than as a result of a contract with an individual composer or recording group.

For the avoidance of doubt, where the Licensee is exploiting the relevant rights outside the United Kingdom, and has in relation to such exploitation a valid licence from the Associated Society entitled to grant that licence in relation to the relevant

territory or territories, this clause 15 does not operate so as to override the terms of that licence.

## **16. Notices**

- 16.1 Except where expressly stated otherwise, any notice or other written communication given under or in connection with this Agreement shall only be effective if it is in writing. Faxes and e-mails are permitted save that notices under clause 12 of this Agreement shall not be served by e-mail. In the absence of any legitimate electronic signature system, either party shall be permitted to require the confirmation in writing (signed by an authorised signatory) of any notice originally sent by email.
- 16.2 The address for service of any party shall be its registered office marked for the attention of the Chief Executive or Managing Director, or, if any other address or addressee for service has previously been notified to the server, to the address so notified. A single notice served on or sent to IMRO and addressed to either Licensor shall be treated as validly served on both Licensors.
- 16.3 Any such notice or other written communication shall be deemed to have been served:
- (a) if personally delivered, at the time of delivery;
  - (b) if posted, at the expiry of two business days or in the case of airmail four business days after it was posted;
  - (c) if sent by facsimile message or e-mail, at the time of receipt of transmission (if received during normal business hours that is 09.00 to 17.00 local time) in the place to which it was sent or (if not received during such normal business hours) at the beginning of the next business day at the place to which it was sent.
- 16.4 In proving service of a notice it shall be sufficient proof that personal delivery was made, or that such notice or other written communication was properly addressed stamped and posted or in the case of a facsimile message or e-mail that an activity or other report from the sender's facsimile machine or computer can be produced in respect of the notice

or other written communication, in the case of a fax, showing the recipient's facsimile number and the number of pages transmitted.

## **17. Miscellaneous**

- 17.1 No delay or omission in exercising any right or remedy hereunder shall operate as a waiver thereof or of any other right or remedy and no single or partial exercise thereof shall preclude any other or further exercise thereof or the exercise of any other rights or remedies. No waiver shall be binding or effectual for any purpose unless expressed in writing and signed by the party giving it and any such waiver shall be effective only in the specific instance and for the purpose given.
- 17.2 This Agreement sets forth the entire agreement of the parties in relation to the subject matter hereof and each of the parties hereto acknowledges that it has not entered into this Agreement in reliance on any representation or term not contained in this Agreement. This Agreement shall not be modified or varied except by a written instrument signed by the parties hereto.
- 17.3 The headings to the clauses in this Agreement are included for ease of reference only and are not part of this Agreement and are not to be taken into account in its construction.
- 17.4 The parties shall (and shall procure that any other necessary party within its control shall) execute and do all such documents acts and things as may be reasonably be required on or subsequent to completion of this Agreement for securing each of the obligations of the respective parties under this Agreement.
- 17.5 If this Agreement creates any rights which would in the absence of this provision be enforceable by any person not a party to this Agreement, such rights shall not be enforceable.
- 17.6 This Agreement shall be construed according to the laws of Ireland and the parties agree to submit to the jurisdiction of the Irish Courts.

## Appendix 2A

### IMRO LIMITED ONLINE EXPLOITATION LICENCE PLUS Royalty Fees (Calendar Year 2024)

Licence Band for LOML +	A	B	C	D	E	F	G	H	I	J	K	L	M	N
<b>Annual licence fee per service (excluding VAT)</b>	€3,242	€4,862	€6,484	€8,104	€9,724	€11,057	€12,966	€14,587	€16,207	€17,828	€19,487	€21,070	€22,691	€24,312
<b>Music download</b> Maximum number of downloads per annum	37,736	56,604	75,472	94,340	113,208	132,075	150,943	169,811	188,679	207,547	226,415	245,283	264,151	283,019
<b>Music download - karaoke</b> Maximum number of karaoke downloads per annum	16,667	25,000	33,333	41,667	50,000	58,333	66,667	75,000	83,333	91,667	100,000	108,333	116,667	125,000
<b>Music on demand</b> Maximum number of on demand streams per annum	765,404	1,148,106	1,530,808	1,913,509	2,296,211	2,678,913	3,061,615	3,444,317	3,827,019	4,209,721	4,592,423	4,975,124	5,357,826	5,740,528
<b>Music on demand - karaoke</b> Maximum number of on demand karaoke streams per annum	508,475	762,712	1,016,949	1,271,186	1,525,424	1,779,661	2,033,898	2,288,136	2,542,373	2,796,610	3,050,847	3,305,085	3,559,322	3,813,559
<b>Music on demand (subscription) –</b> (single, non-portable device, only accessible when online) Maximum number of subscribers per month	417	625	833	1,042	1,250	1,458	1,667	1,875	2,083	2,292	2,500	2,708	2,917	3,125
<b>Music on demand (premium subscription) –</b> (Multi-device, full functionality accessible when offline) Maximum number of subscribers per month	278	417	556	694	833	972	1,111	1,250	1,389	1,528	1,667	1,806	1,944	2,083
<b>Music on demand karaoke - subscription</b> (mobile or online) Maximum number of subscribers per month	278	417	556	694	833	972	1,111	1,250	1,389	1,528	1,667	1,806	1,944	2,083
<b>Webcast</b> Maximum number of streams per annum	3,050,847	4,576,271	6,101,695	7,627,119	9,152,542	10,677,966	12,203,390	13,728,814	15,254,237	16,779,661	18,305,085	19,830,508	21,355,932	22,881,356
<b>Webcast (subscription)</b> Maximum number of subscribers per month	833	1,250	1,667	2,083	2,500	2,917	3,333	3,750	4,167	4,583	5,000	5,417	5,833	6,250
<b>Interactive webcast</b> Maximum number of interactive streams per annum	1,949,153	2,923,729	3,898,305	4,872,881	5,847,458	6,822,034	7,796,610	8,771,186	9,745,763	10,720,339	11,694,915	12,669,492	13,644,068	14,618,644
<b>Interactive webcast (subscription)</b> Maximum number of subscribers per month	758	1,136	1,515	1,894	2,273	2,652	3,030	3,409	3,788	4,167	4,545	4,924	5,303	5,682

## **Appendix 2B**

### **Gross Revenue Definition**

The following definition applies to the following Licensed Services:

**"Gross Revenue"** means, subject to the provisions of this Appendix 2B:

- (a) all revenue received (or receivable) by the Licensee from Users in consideration for the provision of the Licensed Services; and
- (b) all revenue, including by way of sponsorship and commissions, received (or receivable) by the Licensee as a result of the inclusion of third party advertising "in-stream" or "in-download" as part of the Licensed Service, being advertising placed immediately at the start, end or during the actual delivery (by way of streaming or downloading as applicable) of a Repertoire Work to a User; and
- (c) all revenue, including by way of sponsorship, click-throughs and other commissions, received (or receivable) by the Licensee as a result of the placement of third party advertising, buy or click-through buttons on a Relevant Page (as defined below) of the Licensed Service (and including any page which directly follows such Relevant Page leading up to and including the downloading or streaming of the music offering). For the avoidance of doubt, advertising revenue referred to in this sub-paragraph (c) shall not include revenue arising from sponsored searches or click-through commissions arising from such searches;

and in each of the above cases such revenue shall, for the avoidance of doubt, include any such revenue whether received or receivable by the Licensee or any associate, affiliate, agent or representative of such party.

There shall be no other deduction or set-off from the above revenues other than reasonable refunds to Users for services that they were unable to use (but had paid for) due to technical faults in the Licensed Services. For the avoidance of doubt, Gross Revenue shall not be reduced by credit card commissions or similar payment process charges.

For the avoidance of doubt, where the Licensed Service is provided as part of a "portal based service" of which the Licensed Service form only one part of a suite of services including some that do not relate to music in any way, it is not intended that the definition of Gross Revenue set out above includes the entire revenue of the portal or indeed any revenue of the portal which is not attributable to the Licensed Service.

**"Relevant Page"** means a page:

- (a) from which Licensed Services are "actually offered" to Users. A Licensed Service is "actually offered" to Users from a page if Musical Works are enabled or made directly available from that Licensed Service to the User to download or stream from that page (in most cases this will be where such Musical Works can be purchased by the User or their download or stream otherwise takes place); but only
- (b) where such offering forms all or the predominant part of that page, being for the purposes of this Agreement where the offering comprises 75% or more of the space on that page excluding space occupied by any advertising. For the purposes of performing the foregoing calculation, the "offering" shall include any content which directly relates to the actual offering of the Licensed Service pursuant to sub-paragraph (a) above (by way of example, but without limitation, an image of the artist or artwork closely associated with the offering, reviews of the offering, credits, and music player controls).

***Appendix 3***

**Electronic Reporting Format**

To be inserted.





## Performing Right Online Licence 2023

### What is PROL?

The Performing Right Online Licence (PROL) covers the act of making available music to the public when you want to use music online and have already cleared the mechanical rights (i.e., the right to copy/reproduce the track) separately. Examples of services which may have cleared the mechanical rights separately include but are not limited to:

- Individual clearance granted by the publisher
- Production music used online

The licence will run for 12 months from the date of purchase and we require reporting to show which works have been made available. Generally, PROL only covers the territory of Republic of Ireland.

Visit <http://www.imro.ie/music-users/online-and-mobile-music-use/> to apply.

### PROL Royalty Rates

Royalty fees are calculated in blocks of €91 + VAT allowances per block vary depending on the level of usage. Please refer to the table below for more details.

#### 1. Music Services

Service type	Allowance per €91 block
On demand streams	up to 45,000 streams per annum
Background to a website (akin to webcasting)	up to 120,000 streams per annum
Permanent downloads	up to 5,000 downloads per annum
Ringtones	up to 1,000 downloads per annum

#### 2. General Entertainment Services

Service type	Allowance per €91 block
On demand streams	up to 3,200 music hours streamed per annum
Permanent downloads	up to 350 music hours downloaded per annum
Background to a webpage	Up to 8,500 music hours streamed

Please call the licensing team on +353 (1) 644 8023 or email [onlinelicensing@imro.ie](mailto:onlinelicensing@imro.ie) if you have any queries.



# PERFORMING RIGHT ONLINE LICENCE

## TERMS AND CONDITIONS

### 1. Definitions

**“the Act”** means the Copyright and Related Rights Act 2000, as amended from time to time.

**“Agreement”** means these terms and conditions and the AFL completed and signed by the Licensees and signed by IMRO.

**“Application for Licence” or “AFL”** means the IMRO Online Licence application form.

**“Commencement Date”** means the launch date of the Licensed Services as set out in the AFL.

**“Device”** means a portable or static electronic communications device which is capable of allowing Users to communicate with each other via wire and/or wireless networks and which is capable of playing a Ringtone.

**“Dramatico-Musical Work”** means any ballet, opera, operetta, musical, musical play or work of a similar nature.

**“Licensed Service(s)”** means the music or general entertainment service(s) set out in the AFL.

**“Licensee”** means the party that submits an AFL and is granted a licence by IMRO subject to this Agreement.

**“Licensors”** means IMRO and MCPSI

**“MCPS”** means Mechanical-Copyright Protection Society Limited whose registered office is at 2<sup>nd</sup> Floor, Synergy House, 114-118 Southampton Row, London, WC1B 5AA, England contracting for and on behalf of itself and for and on behalf of and as agents of its various Members and affiliated societies.

**“MCPSI”** means mechanical Copyright Protection Society (Ireland) Limited whose registered office is at Copyright House, Pembroke Row, Lower Baggot Street, Dublin 2, Republic of Ireland contracting for and on behalf of and as agents of MCPS its various Members and affiliated societies.

**“Member”** means:

- (a) in the case of MCPSI, each person, firm or company who or which, from time to time, has appointed MCPS as agent in relation to online exploitation either before or during the Term, PROVIDED THAT a member who has so appointed MCPS after the commencement of the Term shall only be regarded as a member for the purposes of this Agreement with effect from the date on which the Member so appointed MCPS; and

- (b) in the case of IMRO, any person, firm or company who or which, from time to time, pursuant to the Articles of Association of IMRO has been admitted either before or during the Term as a member of IMRO, PROVIDED THAT a member who has been so admitted after the commencement of the Term shall only be regarded as a member for the purposes of this Agreement with effect from the date of admission into IMRO.

**“Musical Work”** means any musical work (as defined in the Act) and any lyrics or words written to be used with such musical work (if applicable). It includes any part of such a work.

**“PMSR”** means any production music sound recording being a sound recording (as opposed to a Musical Work) the copyright in which is owned or controlled in the Republic of Ireland by MCPSI (or an MCPS Member or an associated society or an associated society member) and where such party has authorised MCPS to license such recordings as so-called production or library music.

**“IMRO”** means Irish Music Rights Organisation CLG whose registered office is at Copyright House, Pembroke Row, Lower Baggot Street, Dublin 2, Ireland contracting for and on behalf of itself and for and on behalf of and as agents of its various affiliated societies.

**“Repertoire Work”** means:

- (a) in relation to the licence granted by MCPSI, PMSRs; and
- (b) in relation to the licence granted by IMRO, each Musical Work the relevant copyright in which is owned or controlled, from time to time, in Ireland by IMRO or a Member or an associated society or an associated society member PROVIDED THAT if one or more of those who own or control the copyright in a relevant Repertoire Work is not IMRO or a Member or an associated society or associated society member, the expression "Repertoire Work" shall only apply to such interest in the Repertoire Work as is owned or controlled by IMRO or the associated society or the relevant member or associated society member;

**“Consumer Price Index”** shall mean the Irish government’s annual measure of the level of inflation, assessed by reference to the change in the average level of prices at retail of a defined group of goods and being the main index as published by the Central Statistics Office

**“Ringtone”** means a short audio recording incorporating a Repertoire Work (or part thereof) the primary purpose of which is to notify the User of an incoming telephone call or message on a Device.

**“Royalty Fees”** means the royalties payable by the Licensee to IMRO, as set out in clause 5.

**“Service Provider”** means, the party which, in relation to a Licensed Service, most closely meets the following criteria:

- (a) contracts with the User in relation to the provision of the Licensed Service;
- (b) sets and controls the price the User pays;
- (c) can fully report on all elements of the gross revenue (including relevant advertising revenues) of the Licensed Service;
- (d) can fully report on all elements of music usage (or can procure such reporting);
- (e) controls how content is offered and bundled within the Licensed Service; and
- (f) carries out or authorises, on their instruction, the carrying out of the copyright restricted acts licensed under this Agreement.

**“Term”** means the period starting on the Commencement Date and ending upon 31 December 2024 unless expiring or terminating earlier in accordance with the provisions of clauses 5 or 10 of these standard terms and conditions.

**“Territory”** means Ireland and such other countries as IMRO and the Licensee may agree in writing.

**“User”** means a natural person in the Territory who receives the Licensed Services for their own private and non-commercial use.

**“VAT”** means value added tax and each like tax imposed in addition to or in substitution therefor.

## 2. Grant of Licence

2.1 Subject to and conditional upon compliance with the terms and conditions contained herein and in particular subject to the exclusions and restrictions set out in clauses 3 and 4, MCPSI grants the Licensee a non-exclusive licence, during the Term, to make available to the public (as that term is defined in the Act) and to authorise the making available to the public of the PMSRs set out in the AFL within the Territory solely as part of and for the purposes of the provision of the Licensed Service to Users using the internet.

2.2 Subject to and conditional upon compliance with the terms and conditions contained herein and in particular subject to the exclusions and restrictions set out in clauses 3 and 4, IMRO grants the Licensee a non-exclusive licence, during the Term, to make available to the public (as that term is defined in the Act) and to authorise the making available to the public of the Repertoire Works set out in the AFL within the Territory solely as part of

and for the purposes of the provision of the Licensed Service to Users using the internet.

2.3 Subject to and conditional upon compliance with the terms and conditions contained herein, IMRO grants the Licensee a non-exclusive licence during the Term to authorise the public performance (as that term is defined in the Act) in the Republic of Ireland of Repertoire Works in the form of Ringtones resulting from the playing in public of Ringtones on Users’ Devices as part of the ordinary use of such Devices.

## 3. Exceptions and Limitations

3.1 The licences granted under this Agreement are valid only insofar as the Licensee is the Service Provider in relation to the Licensed Services.

3.2 For the avoidance of doubt, licences granted under this Agreement do not grant any “synchronisation licence” covering the initial fixation of Repertoire Works in combination with visual images to create and produce content.

3.3 Save as permitted under clause 2.3 above in respect of Ringtones, for the avoidance of doubt, the licences granted under this Agreement shall not extend to the public performance (as that term is used in the Act) of Repertoire Works, whether as part of the Licensed Service or otherwise.

3.4 The licence granted under clause 2 shall only apply to a Repertoire Work or PMSR communicated to the public as part of the Licensed Service where the Licensee has the benefit of a valid licence for or a right to make a reproduction of that particular Repertoire Work or PMSR and for that particular form of exploitation via the Licensed Service.

3.5 For the avoidance of doubt, this Agreement grants no licence whatsoever in relation to Repertoire Works or PMSRs which are:

- (a) made available by the Licensee outside of the Licensed Service; or
- (b) made available (whether within or outside of the Licensed Service) and are licensable under MCPSI-IMRO various joint schemes for online and mobile services.

## 4. Further Restrictions

4.1 The licence granted under clause 2.2 shall only apply to Repertoire Works not forming part of any Dramatico-Musical Work.

4.2 The licences granted under this Agreement shall not extend to or permit any adaptation of any Repertoire Work or PMSRs to be communicated to the public as part of a Licensed Service unless the owner of such rights has expressly consented to such adaptation.

4.3 The licences granted under this Agreement do not extend to the communication to the public of any Repertoire Work or PMSR:

- (a) in the form of a parody, pastiche or burlesque of any Repertoire Work or of any composer or writer of any Repertoire Work PMSR or any band or other group of artists which includes any composer or writer of any Repertoire Work or PMSR; or
- (b) where there is a derogatory, facetious, obscene or demeaning reference to the Repertoire Work or PMSR, its composer(s) and author(s) or the performing artist.

4.4 All rights not specifically granted under this Agreement are hereby reserved.

4.5 This Agreement only covers Repertoire Works and PMSRs. It does not extend to other rights or interests, including (by way of example only), rights in sound recordings (other than PMSRs), films, dramatic works, performers' rights or rights in performances. The Licensee is required to obtain the appropriate waivers, consents and/or licences from the person(s) owning or controlling rights in relation to sound recordings containing Repertoire Works or PMSRs or performers of that Repertoire Work or PMSR.

4.6 It is the responsibility of the Licensee to obtain all necessary licences in relation to any Musical Work which is not, or to the extent that it is not, a Repertoire Work, and no licence is granted under this Agreement in relation thereto.

4.7 Nothing in this Agreement affects the moral rights of authors of Repertoire Works or PMSRs whether subsisting in Ireland or any other territory.

**5. Fees and Payment**

5.1 In consideration of the licence and authorisations granted under this Agreement, the Licensee shall pay to IMRO the following Royalty Fees annually in advance for each consecutive 12 month period until expiry or termination of the Agreement:

<b>MUSIC SERVICES</b>	<b>€91 (+VAT) per annum</b>
<b>Permanent Downloads</b>	Up to 5,000 downloads per annum
<b>On-Demand Streams</b>	Up to 45,000 streams per annum
<b>Background to Webpage (akin to webcasting)</b>	Up to 120,000 streams per annum

<b>Ringtone Downloads</b>	Up to 1000 downloads
---------------------------	----------------------

<b>GENERAL ENTERTAINMENT SERVICES</b>	<b>€91 (+VAT) per annum</b>
<b>Permanent Downloads</b>	Up to 350 music hours downloaded per annum
<b>On-Demand Streams</b>	Up to 3,200 music hours streamed per annum
<b>Background to Webpage</b>	Up to 8,500 music hours streamed

General entertainment services are licensed with reference to the amount of music hours consumed. For example, a streamed video featuring 3 minutes of music streamed 20,000 times equates to 60,000 music minutes or 1,000 music hours. This is therefore within the limit allowed under the €75 minimum.

5.2 The first 12 month period shall commence on the Commencement Date. For each consecutive 12 month period thereafter the Licensee shall pay the Royalty Fee no later than the final day of the preceding 12 month period. In the event that the Licensee fails to pay the Royalty Fee by such time, this Agreement will automatically expire and the notice provisions in clause 10 shall not apply.

5.3 The Royalty Fees set out in clause 5.1 above shall be calculated as multiples of €86 only with a minimum fee of €86 (excluding VAT) per annum.

5.4 The Royalty Fees set out in clause 5.1 above shall be cumulative. By way of example only, the Royalty Fees payable for a music service which provides less than 45,000 on demand streams and up to 5,000 permanent downloads per annum shall be €172 (excluding VAT).

5.5 If the combined Royalty Fees in respect of the Licensed Services under this Agreement exceed €344 (excluding VAT) per annum, this Agreement shall not apply and the Licensee must contact IMRO.

5.6 IMRO shall be entitled to increase the Royalty Fees at the start of each calendar year based on increases in the Consumer Price Index over the preceding year. The new Royalty Fees will be published on IMRO's website and will apply to any 12 month extension of the licences granted under this Agreement during that calendar year.

5.7 The Licensee shall notify IMRO immediately if the maximum usage limits set out in clause 5.1 above are exceeded.

5.8 The Licensee shall notify IMRO promptly of any material change in the information provided in the AFL and the effective date of such change.

5.9 IMRO shall raise an invoice for the due amount, and the Licensee shall pay such invoice in full by electronic transfer within 21 days of the invoice date. Such invoice shall be for the full amount payable for one year of the Term of the Agreement.

5.10 All licence fees and payments referred to in this Agreement are subject to VAT or other equivalent sales tax. The Licensee shall pay to IMRO VAT or other equivalent sales tax (if applicable) at the rate or rates from time to time in force on any sums payable under this Agreement.

5.11 Except as expressly set out in these terms and conditions, no deduction in respect of any tax, or any other deduction or set-off of whatsoever nature, shall be made in calculating or paying any sum due under this Agreement

5.12 Without prejudice to any other right or remedy of IMRO, and without imposing an obligation to accept late payment, where any fees payable under this Agreement are not paid by the due date (or the date on which such fees should ordinarily have been paid in circumstances where IMRO have been unable to submit an invoice) due to default of the Licensee, the Licensee shall (if required by IMRO) pay interest on such late payment calculated on a daily basis at an annual rate of 3% over the base rate, current from time to time, of National Westminster Bank Plc payable from the date on which the payment should have been made to the date on which the payment was made.

5.13 All payments made under this Agreement shall be in Sterling unless otherwise agreed by the parties in writing. Where it is necessary to convert an amount payable to Sterling from another currency, the exchange rate used shall be the Financial Times closing mid market rate on the date of the invoice. The Licensee shall pay all bank charges on transfers of sums payable by the Licensee to IMRO.

## 6. Supply of Information

6.1 In relation to any and all Repertoire Works that the Licensee expects to communicate to the public under this Agreement via all Licensed Services, the Licensee shall provide IMRO with full and accurate details in the AFL for each consecutive 12 month period for the duration of the Term.

6.2 The Licensee must also supply IMRO with any further information or documentation in its possession, power, custody or control (and use its reasonable endeavours to supply IMRO with any further information or documentation not in its possession, power, custody or control) reasonably requested by IMRO at any time, in order to enable IMRO to verify the Repertoire Work(s) which have

been reproduced or distributed via all Licensed Services.

6.3 Where any or all of the Licensed Services are accessible by Users only on payment of subscription or other similar payment (or access is otherwise limited or controlled in some way), the Licensee shall, upon request of IMRO, use reasonable endeavours to ensure that such Licensed Services are at all times accessible by IMRO free of charge for the purposes of IMRO verifying that the Licensee is acting in accordance with this Agreement.

6.4 Without prejudice to any right in law that IMRO may have to obtain such information, the Licensee shall not be obliged to provide to IMRO any information which identifies Users or which otherwise constitutes "personal data" as defined in the Data Protection Act 1998. For the avoidance of doubt, the Licensee must still provide all required music usage information (or other information to be provided under this Agreement), but is entitled to remove any element of it which reveals the identity of Users or otherwise causes it to include or constitute "personal data".

## 7. Credits and Notices

The Licensee shall include on each of the Licensed Services:

- (a) the logo of IMRO; and
- (b) details of the following website and, where practical, hypertext links to it:  
[www.imro.ie](http://www.imro.ie)

Approval of IMRO shall be deemed to be given to the positioning of the above credits and notices within the terms and conditions of the Licensed Service(s) where it is not reasonably practical to position such information elsewhere.

## 8. Auditing

8.1 The Licensee shall keep and make available for inspection upon reasonable notice (and shall procure that each relevant party keeps and makes available for inspection upon reasonable notice), both during and for twelve months after termination of this Agreement, proper, detailed books and records relating to use of all Musical Works and PMSRs, together with any supporting documentation relating thereto covering the period up to six years prior to the date of notification of audit. Where any agreement between the Licensee and IMRO replaces this Agreement or licenses substantially the same activities (the "**Replacement Agreement**"), the twelve month time-limit referred to above shall begin following termination or expiry of the Replacement Agreement.

8.2 For the purposes of this clause 8, the Licensee shall allow upon reasonable notice (and shall procure that

each relevant party shall allow) access to its premises to inspect relevant accounting records, but not more than once per annum. The duly authorised representatives (who shall be external qualified accountants or auditors unless otherwise agreed between the parties) of IMRO shall have such access to the Licensee's premises and shall be entitled to inspect, make extracts and take copies of any of the information and/or documentation available and to carry out such work as is, in their reasonable opinion, considered necessary to verify compliance with this Agreement.

8.3 IMRO shall not (and shall procure that their representatives shall not), without the Licensee's written consent, disclose to any third party any confidential information of the Licensee (so long as it remains confidential) received in the course of an audit carried out under this clause 8, save that such confidential information may be disclosed to IMRO' directors, board subcommittee members officers, employees and professional advisors (solely where such persons are under a duty of confidentiality in relation to information so received and IMRO shall be liable to the Licensee in respect of any breach of such confidentiality obligation) solely for purposes connected with this Agreement.

8.4 For the avoidance of doubt, books, records and accounting records as referred to in clauses 8.1 and 8.2 above shall include data, information and records held on computers.

## 9. Security and Encryption

Unless agreed otherwise, the Licensee will utilise or require the utilisation of an industry security standard which is developed and is available for use in the protection of Repertoire Works. Until such time, the Licensee must use its reasonable endeavours to prevent unauthorised copying and/or the unauthorised issuing of copies of Repertoire Works by whatever technical means are practicable. Upon request the Licensee will inform IMRO concerning its progress in relation to fulfilling this obligation.

## 10. Termination and Expiry

10.1 The Licensee may terminate this Agreement by giving not less than three months written notice to IMRO. No refund of Royalty Fees shall be provided to the Licensee where the Licensee terminates the Agreement under this clause 10.1.

10.2 IMRO may terminate this Agreement by giving not less than three months written notice to the Licensee provided that:

(a) where IMRO replace the IMRO Online Licence with a similar licensing scheme, IMRO will credit to the Licensee under such new licensing scheme a pro-rated portion of the Royalty Fees paid by the Licensee corresponding to the unexpired portion of the 12 month licence period remaining after the expiry of the notice period; or

(b) where no replacement licence to the IMRO Online Licence is to be offered by IMRO, IMRO will refund a prorated portion of the Royalty Fees paid by the Licensee corresponding to the unexpired portion of the 12 month licence period remaining after the expiry of the notice period.

10.3 A party shall have the right to terminate this Agreement by notice forthwith where the other party:

(a) commits a material breach of this Agreement which is capable of remedy and fails to remedy such breach within 14 clear days after receipt of notice of such breach; or

(b) commits a material breach of this Agreement which is not capable of remedy; or

(c) goes into receivership or any resolution is passed for its winding-up or liquidation (other than for the purposes of reconstruction or amalgamation) or is otherwise unable to pay its debts,

and, for the avoidance of doubt, any breach which consists of a failure by either party to perform an obligation under this Agreement within any period required or by any date specified under this Agreement shall be deemed to be capable of remedy if such obligation is performed by such party within the 14 day remedy period specified in clause 10.3(a) above.

## 11. No Assignment

The licences granted under this Agreement are personal to the Licensee and the Licensee may not assign, sub-license or otherwise transfer any or all of its rights or obligations under this Agreement without the prior written agreement of IMRO.

## 12. Miscellaneous

12.1 No delay or omission in exercising any right or remedy hereunder shall operate as a waiver thereof or of any other right or remedy and no single or partial exercise thereof shall preclude any other or further exercise thereof or the exercise of any other rights or remedies. No waiver shall be binding or effectual for any purpose unless expressed in writing and signed by the party giving it and any such waiver shall be effective only in the specific instance and for the purpose given.

12.2 This Agreement sets forth the entire agreement of the parties in relation to the subject matter hereof and each of the parties hereto acknowledges that it has not entered into this Agreement in reliance on any representation or term not contained in this Agreement. This Agreement shall not be modified or

varied except by a written instrument signed by the parties hereto.

12.3 The headings to the clauses in this Agreement are included for ease of reference only and are not part of this Agreement and are not to be taken into account in its construction.

12.4 The parties shall (and shall procure that any other necessary party within its control shall) execute all such documents and do all such acts and things as may be reasonably be required on or subsequent to completion of this Agreement for securing each of the obligations of the respective parties under this Agreement.

12.5 If this Agreement creates any rights which would in the absence of this provision be enforceable by any person not a party to this Agreement, such rights shall not be enforceable.

12.6 This Agreement shall be construed according to the laws of Ireland and the parties agree to submit to the jurisdiction of the Irish Courts.